



**DRILLING
SCREW BITS
SAWING**



NEW
DUST-FREE DRILL BIT
SPEEDUSTER 646

DIAGER[®]
PROFESSIONAL TOOLS MANUFACTURER

A professional range

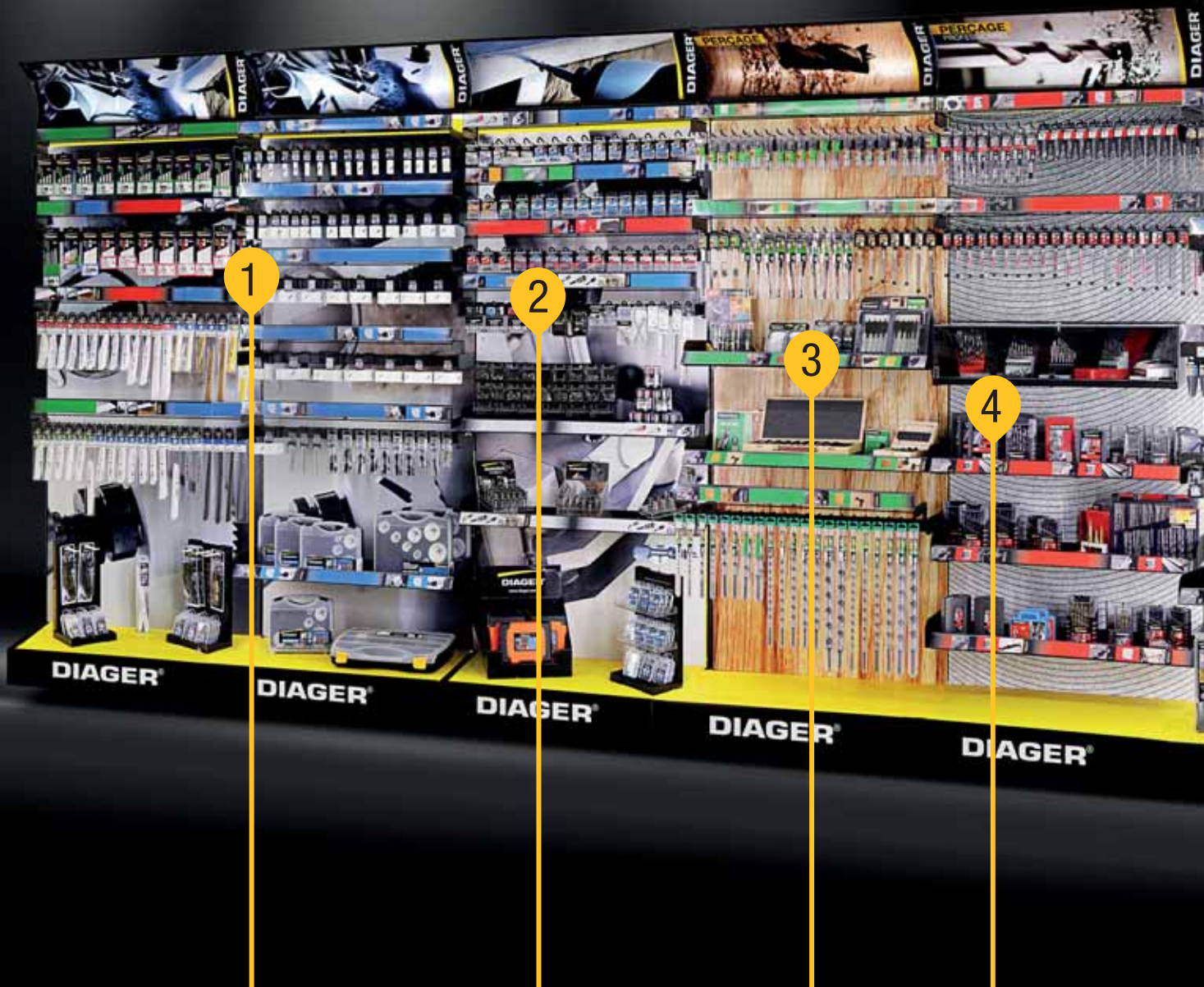

SAWING

8% Cobalt holesaw, jigsaw blade and reciprocating saw blade.

SCREW BITS

Bit holder, torsion screw bits for driller and impact driller, long series screw bits.

DRILLING

WOOD
Drill bits for hard wood and low density wood, Auger bit, Flat bit, Decking kit, Forstner bit and Disc plug cutter.

DRILLING

METAL
Metal drill bit for steel and alloy steel, TCT HSS drill bit, Tap, Die, screw extractor.

XXL

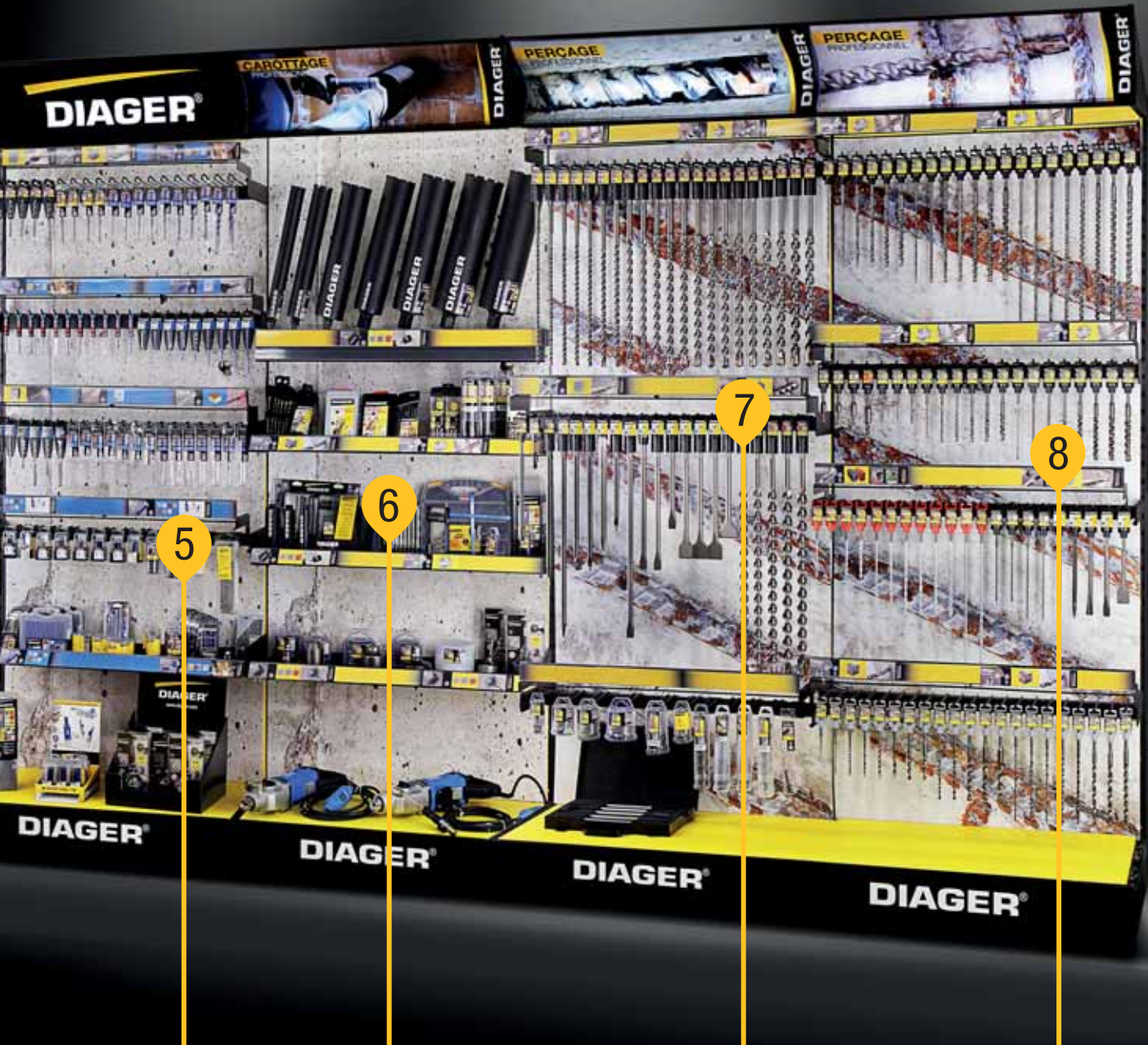

DRILLING

SPECIFIC

Specific material drilling, ceramic, glass, gre-ceram, composite, HPL, cement fibre, tile.

CORING

Diamond core bit, drill motor and drilling stand. Diaond core bit and carbide core bit.

DRILLING

SDS-MAX

SDS-max drill bit for concrete, reinforced concrete and hard rock. Drill bit up to 4 meters long. Pointed and flat chisels.

DRILLING

SDS-PLUS

SDS-plus drill bit for concrete and reinforced concrete, granit, brick, breeze block. Pointed and flat chisels.

DRILLING

Concrete

CONCRETE - HAMMER DRILL BIT

Booster-Plus	Ref. 113-157K-157L-157M	14-17
Stop drill bit	Ref. 108	18
Windows and frames drill bit	Ref. 102-103	19
Twister-Plus	Ref. 110-108K-108L-108R	20-21
Wallster	Ref. 104	22-23
Granit	Ref. 184	24
Compatible SDS-top, Spline, Split	Ref. 131-133-120-111	25
Ultimax	Ref. 166	26-27
Ultimax 646		28-29
Speeduster	Ref. 161	30-31
Power-Max	Ref. 370B>376B	32-33
Crosser	Ref. 165	34

ACCESSORIES

Adapter and Chuck adapter	Ref. 138B-143B-147B-172B-177B	35
Chuck	Ref. 120K > 124K	36

TOOL FOR HAMMER DRILLS

Helical pointed chisel	Ref. 322-323-342-395	37-38
Flat chisel	Ref. 318-319-343-396	38
Bush hammer head	Ref. 363	39
Angled bolster	Ref. 348-349-397	39
Toothed chisel	Ref. 361	39
Jointed chisel	Ref. 329	39
Concrete chasing chisel	Ref. 311-312	39
Brick chasing chisel	Ref. 314	39

TOOL FOR ELECTRIC CONCRETE BREAKER

Pointed chisel	Ref. 310-324-359-354-393	40
Flat chisel	Ref. 347-320-355-341-394	41

DIAMOND

Diamond core bit	Ref. 436-439B	44-45
Drill motor	Ref. 349H-350H-351H-352H-398H	46
Drilling stand	Ref. 348H-353H-354H-355H	47
Accessories		48
Blue Ceram	Ref. 426-416	50
Diamond core bit	Ref. 431-432	51
Accessories		51

CARBIDE CORE BIT

Carbide core bit & accessories	Ref. 326-366-300	52-53
---	------------------	--------------

CONCRETE - STRAIGHT SHANK

Optima3+	Ref. 263	54
Mega	Ref. 226	55
Pro	Ref. 264	55
Flash	Ref. 265	56

Specific

Multimaterials	Ref. 215	57
Ceramik drill bit	Ref. 245	58
Hard stone & granit drill bit	Ref. 208	58
Scribing iron	Ref. 403	58
Carbide claw	Ref. 407	58
Ceratile	Ref. 400	59
HPL bit	Ref. 201	60
Ice drill bit	Ref. 170B-170	60

Special driller

Hexa, wood drill bit	Ref. 781-981	61
-----------------------------	--------------	-----------

HSS-metal

5% Cobalt drill bit	Ref. 731-700	68
HSS-G3 drill bit	Ref. 702-703	69
TIN drill bit	Ref. 732-728	70
Pro drill bit	Ref. 729-726-735-713-712-715	71-73
Roll forged drill bit	Ref. 769-750	74
5% cobalt TIALN Step drill bit	Ref. 500B-501B-502B	75
Step drill bit	Ref. 511B-512B-513B	75
Tap and Die	Ref. 865-867-827-825-826-829	76
Screw extractor	Ref. 634	77
Contersink	Ref. 504	77
TCT HSS drill bit	Ref. D2409-D2418	78

Wood

Auger bit Super Pro	Ref. 912-913-941-946-942-943	84
Flat bit & accessories	Ref. 904-906-908	85
Forstner Woodmax bit	Ref. 934	86
Forstner Woodmax carbide bit	Ref. 936	86
Extension	Ref. 937	87
Disc plug cutter	Ref. 928	87
Formwork drill bit	Ref. 723M-722M	87
Depth adjuster collars	Ref. 938C	87
Wood countersink	Ref. 939	87
4 points drill bit - 4Wood	Ref. 910	88
3 points drill bit	Ref. 915-918	88
Decking kit	Ref. 902-911	89



SAWING

HOLESAW

Bi-Metal holesaw	Ref. 650	110
Accessories		112-113

JIGSAW BLADE

Wood	Ref. L000W > L101W	122-126
Specific	Ref. L012S	127
Metal	Ref. L000M > L102M	128-129

RECIPROCATING SAW BLADE

Wood	Ref. L200W > L202W	130
Specific	Ref. L200S > L204S	131-133
Metal	Ref. L200M > L205M	134-135

Sets

Concrete	62-63
Specific	64-65
HSS-Metal	80-81
Wood	90-91
Screw bits	106-107
Holesaw	111

INFORMATIONS

Company resentation	6-9
Symbols	10-11
Drilling concrete guide	12-13
Hammer drills & attachments compatibility	42
Drilling core guide	43
Drilling metal guide	66-67
Drilling wood guide	82-83
Screw bits manual	92-93
Jidsaw and reciprocating balde manual	114-121
Textile	137
Merchandising	138-141
Services	142-143



SCREW BITS

IMPACT BLUE SHOCK SCREW BIT

Phillips	Ref. U610PH	94-95
Pozidriv	Ref. U612PZ	94-95
Torx	Ref. U613T	94-95
Bit holders	Ref. U621B	94

SCREW BIT STAINLESS STEEL

Flat	Ref. U650PL	96
Phillips	Ref. U650PH	96
Pozidriv	Ref. U650PZ	96
Torx	Ref. U650T	96

DIATIN SCREW BIT

Flat	Ref. U631PL	97
Phillips	Ref. U630PH	97
Pozidriv	Ref. U632PZ	97
Torx	Ref. U633T	97

TORSION SCREW BIT

Flat	Ref. U641PL	98-99
Phillips	Ref. U640PH	98-99
Pozidriv	Ref. U642PZ	98-99
Torx	Ref. U643T	98-99

REDUCED SECTION QUALITY SCREW BIT

Torx Temper	Ref. U624TT	100
Hex	Ref. U625HEX	100
Phillips	Ref. U620PH-U640PH	100
Pozidriv	Ref. U622PZ-U642PZ	100
Torx	Ref. U623T	100

QUALITY SCREW BIT

Torx Temper	Ref. U624TT	101
Square	Ref. U627SQ	101
Hex	Ref. U625HEX	101
Spanner	Ref. U628SP	101
Torx® TTAP®	Ref. U626TTAP	101

ACCESSORIES

Bit holders	Ref. U637-U634-U639 U648-U633-U628-U629 U635-U638-U626	102-103
90° angle driver	Ref.637	104
Handle 1/4" with flexible shaft	Ref.644	104
Telescopic handle 1/4"	Ref.646	104
Quick lock handle 1/4"	Ref.645	104
Power Bushing	Ref. U601	105
Pro magnetic Bushing	Ref. U600-U603	105
Sockets	Ref. U636	105
Stopvis	Ref. 627	105

Values nurtured day to day



Diager is a family-owned company, a French industrial firm with acknowledged know-how, innovative products, teams attentive to the field. Above all it is a state of mind, values that have always be implemented with the same exactingness. These values drive our development.

The human aspect is the essence of Diager: training for our teams, respect for jobs and employees, proximity to our customers whose expectations regarding products, merchandising solutions and services guide our research and development initiatives.

Established in a region where nature is a fundamental asset, our company has the preservation of the environment in its genes. The approach that was innovative fifteen years ago is now the basis of all our thinking and of every facet of our business.

We have never been lured by profit to relocate abroad. The independence of our choices is proof of constancy in our decision-making and of longevity.

Manufacturing our own production equipment, this year we invested two million euros to further improve our manufacturing processes.

Our strategy is to maintain an industrial fabric in France and in Europe. Proof of this lies in our acquisition in 2013 of the German bit manufacturer USH, one of the only European producers of bits and tools. This opportunity also enabled us to widen our scope of skills beyond our diamond formulation expertise and drilling and fastening know-how.

More than a fad, anticipation has been a value we have cultivated for more than sixty years with the single goal of ensuring the sustainability of our company and the satisfaction of our clients in the interest of their customers.

The launch of our business in Mexico in 2011 contributes to reaching our goal. We have chosen to build a local response to close the gap with the needs of local markets.

Currently, it is the appropriation of these values by our employees and our customers that more than ever supports us and drives us forward.

**François Defougères,
CEO.**





Societal commitment

Sustainable development is "development that meets the needs of the present without compromising the capacity of future generations to respond to theirs".

The notion of sustainable development rests on three pillars: economic, ecological and societal.

At Diager, sustainable development is implemented in many ways beginning with the sustainability of our products. While many wonder about the provenance or the traceability of consumer goods, the Guaranteed French Origin certification reassures our customers and reflects our commitments.

Diager has held this certification since 2012 for its percussion drill bits, cylindrical drill bits and diamond tools. This national certification provides clear and transparent information to consumers on the origin of the product and its manufacturing

process. It enhances productive activities and jobs created in France. It guarantees that 50% of the value of the product has been acquired in France and that the places from which it draws its characteristics are located in France. From a purely environmental point of view, Diager holds ISO 14001 certification. Innovative fifteen years ago, today this initiative is the foundation of all our thought-processes and every aspect of our business. It reflects a proactive approach to research and development.

Le développement durable est soutenu par des actions volontaires et innovantes qui se



Our commitments are reflected in concrete actions. Our deliberate approach to preserve the environment is deployed along four lines:

- Reduction of CO2 emissions.

Diager recovers the heat from its production equipment to heat its workshops, uses a boiler fueled with wood chips to heat administrative buildings and works with local partners to reduce the transportation of its products. Since September 2011, the company has optimized domestic single package transport which represents savings of 1600 equivalent tons of carbon each year (or roughly 35%

of the company's overall emissions). In 2014 Diager invested in 4 electric vehicles.

- Sorting and separation of waste for recycling.
- Control of releases into the atmosphere. Diager filter its releases into the air to preserve the environment and guarantee better air quality for neighboring populations.
- Savings in natural resources.

Diager has reduced its water consumption by 40% in ten years by improving its industrial process.



BV Cert. 6020227
Jura



SPONSORSHIP

Our commitment requires rigor, efforts and a true competitive spirit. This is reflected in our sponsorship of charities and general interest activities.

Our first partnership was built with the Royal Salt Works at Arc et Senans, designed by the architect Claude-Nicolas Ledoux, classified by UNESCO as a world heritage monument in 1982. The Royal Salt Works are a rare testimony to the history of industrial architecture. Diager contributes to maintaining this historic building and its gardens. These 14 ephemeral gardens mobilize each year more than 20 institutions and 500 young people in training.

Our second commitment is a sports partnership with Club Triath'lons (www.triathlons.com). The athletic values of the triathlon are close to those of Diager: humility, surpassing oneself and management of effort over time. Among the members of Triath'lons is the long distance para-athlete world champion and several Ironman winners.



Symbols

Materials

Masonry

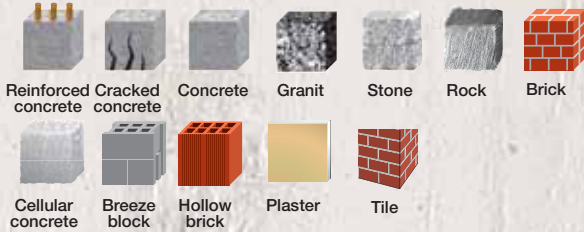

Bois



Metals



Specifics

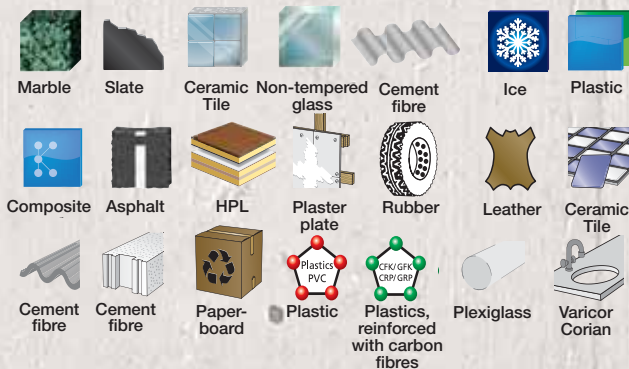

Insulation



Diamond Tools

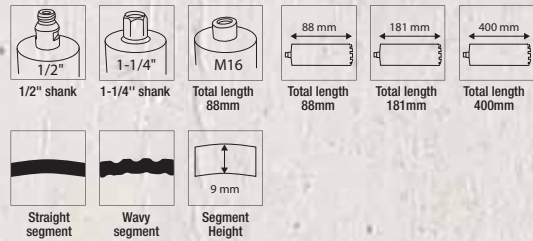

Metal drill bits

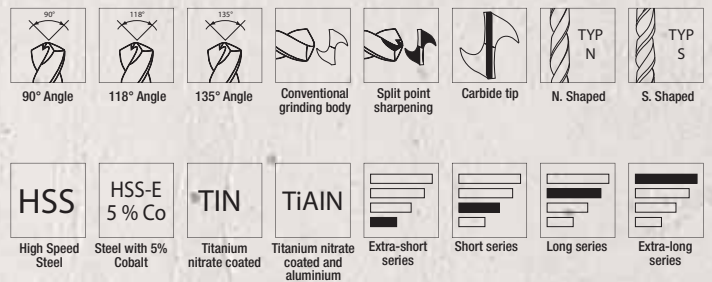

Fixing

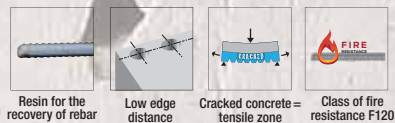

Taps & Dies



Motors



Use

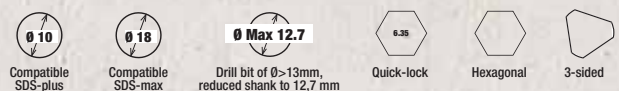

Packaging Legends



The Regulations the construction product (EU Regulation n°305/2011 said CPP) entered into force on 1 July 2013 requires that any construction product conformity with a harmonized standard or to a technical evaluation European (ETE) (1) has a statement of Performance (DoP) and either marked this before it can be placed on the European market. The ETE (2) is issued on the basis of a document on the evaluation of European Guides type of European technical approvals (ETAG) when it was published before 1 July 2013. A ETE option 1 authorizes the anchorages in the cracked concrete and not cracked. A ETE option 7 authorizes the anchorages in the uncracked concrete only. It specifies the performance and the conditions of implementation (dimensions of the holes, cleaning, etc...) the DoP expresses the performance of a construction product at the level of its essential characteristics. (1) replaces therefore gradually the European Technical Approval (ETA). (2) ETA in English



Prüfgemeinschaft

The PGM is an independent body which certifies hammer and straight shank drill bits since 1978. He stays up the standards, and, checks products and policies of quality monitoring of the manufacturers.

Drill bits have to meet the requirements of a strict specifications with the aim of allowing safe anchorings.

These controls carry among others, on the diameter, the centring of the carbide tip, the straightness of drill bits.



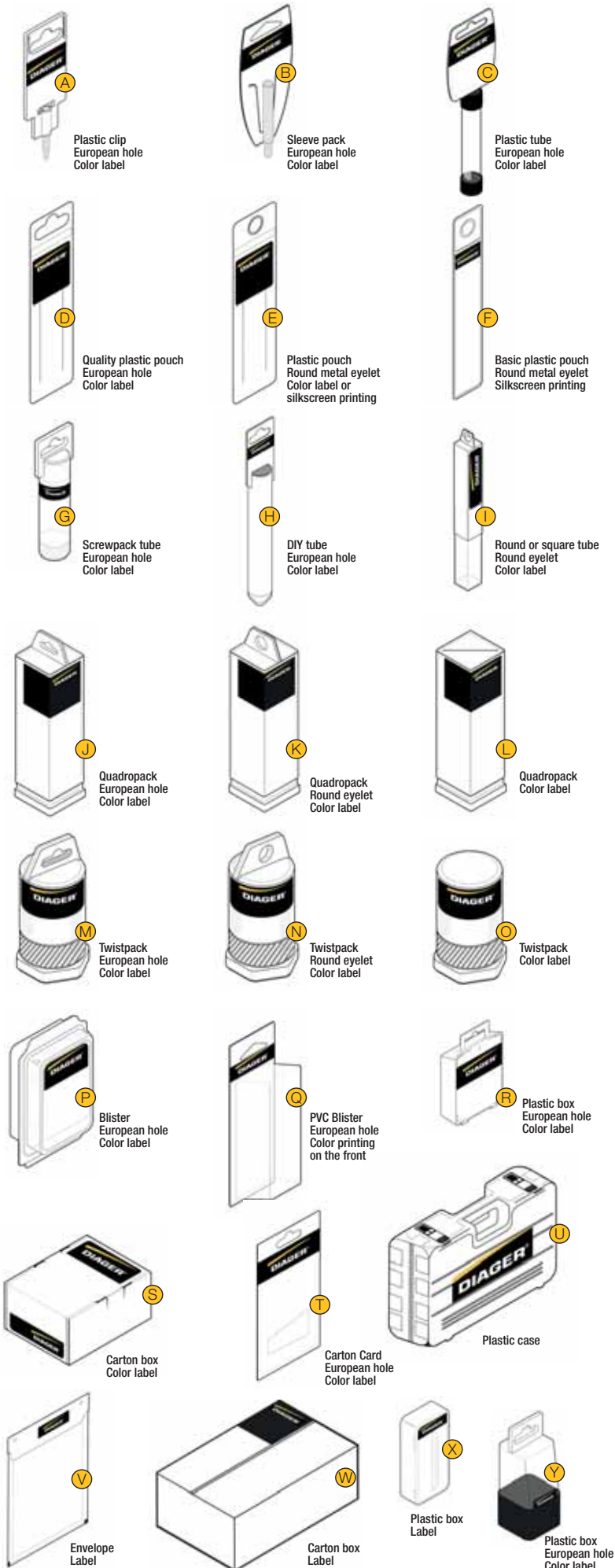









Certified drill bits are stamped with the PGM logo with the manufacturer number.



Common

Ø	Tool's diameter
Øint.	Inside diameter
Øext.	Outside diameter
Øatt.	Shank diameter
ØxP.	Diameter x Depth
ØxPas	Diameter x Metrical Thread
Lu	Working length
Lt	Total length
L200 x 340	WLxTL
Larg.	Tool's width
Ep.	Thickness
L	Length
N.S	Tool height
ml	Segments quantity
Coul	Volume (in ml)
Qt.	Colors
UC	Quantity
Pack	Multiple of order
Pcs	Packaging
	Quantity per set
mm/tpi	Quantity of teeth

Drilling concrete guide

Ref	Features	Attachment	Origin & Standards	Benefits	Page	Reinforced Concrete	Concrete	Granit	Stone, Rock	Brick	Cellular concrete	Breeze block	Hollow brick
113	Booster	SDS-plus		<ul style="list-style-type: none"> • Drill rebar • Guarantee of perfect round and calibrated hole • Drills without cracking the concrete 	14-17	Optimal	Optimal		Optimal	Occasional			
110	Twister	SDS-plus		<ul style="list-style-type: none"> • Speed • Longer life time 	20-21		Optimal		Optimal	Occasional			
104	Wallster	SDS-plus		<ul style="list-style-type: none"> • Perfect design for hollow bricks • Perfect anchoring of plugs 	22-23						Occasional	Optimal	Optimal
108	Stop drill bit	SDS-plus		<ul style="list-style-type: none"> • Perfect for fast volume drilling • Depth control • Drill rebar 	18	Optimal	Optimal		Optimal	Occasional			
102	Windows & Frame drill bit	SDS-plus		<ul style="list-style-type: none"> • Doors and windows frame applications • Guarantee of perfect round and calibrated hole • Elasticity resistance 	19	Optimal	Optimal		Optimal	Occasional			
184	Granit	SDS-plus		<ul style="list-style-type: none"> • Drilling into granit from class 1 to 3 	24		Optimal	Optimal	Optimal	Optimal			
166	Ultimax	SDS-max		<ul style="list-style-type: none"> • Rebar drilling • Longer life time • Avoid risk of blocking • Guarantee of perfect round and calibrated hole 	26-27	Optimal	Optimal	Occasional	Optimal	Occasional			
161	Speeduster 646	SDS-max		<ul style="list-style-type: none"> • Rebar drilling • Work without dust • Retroactive rebar connection 	30-31	Optimal	Optimal		Optimal	Occasional			
165	Crosser	SDS-max		<ul style="list-style-type: none"> • Shipyards of renovation, install electrical enclosures... • Deep drilling in crossing • Important diameter 	34		Optimal		Optimal	Optimal		Occasional	
373B	Power-Max	SDS-max		<ul style="list-style-type: none"> • Big diameter • Deep drilling • Modular system 	32-33		Optimal		Optimal	Optimal		Occasional	
322 323 342 395	Helical pointed chisel	SDS-plus SDS-plus & SPIT SDS-max SDS-top		<ul style="list-style-type: none"> • Effortless drilling • Anti-lock 	37-38		Optimal		Optimal	Optimal		Optimal	
310 324 359 354 393	Pointed chisel	For electric breaker		<ul style="list-style-type: none"> • For electric breaker • Intensive work • Robust and power of optimal typing 	40		Optimal		Optimal	Optimal		Optimal	
318 319 343 396	Flat chisel	SDS-plus SDS-plus & SPIT SDS-max SDS-top		<ul style="list-style-type: none"> • Intensive work • Robust and power of optimal typing 	38		Optimal		Optimal	Optimal		Optimal	
320 355 347 341 394	Flat chisel	For electric breaker		<ul style="list-style-type: none"> • Intensive work • Robust and power of optimal typing 	41		Optimal		Optimal	Optimal		Optimal	

 *Optimal*  *Occasional*

Ref	Features	Attachment	Origin & Standards	Benefits	Page	Concrete	Granit	Stone / Rock	Brick	Cellular concrete	Breeze block	Hollow brick	Plaster	Low density wood	Steel	Marble	Slate	Ceramik	Tiles up to 5° class	No-tempered glass	Corrosion Resistant Facades, composite, up	Ice	Plastic
263	Optima 3+	Straight shank		<ul style="list-style-type: none"> Self centering tip Round and calibrated hole for perfect anchoring 	54																		
226	Mega	Straight shank		<ul style="list-style-type: none"> Intensive use Longevity and performance 	55																		
264	Pro	Straight shank		<ul style="list-style-type: none"> Speed 	55																		
265	Flash	Straight shank		<ul style="list-style-type: none"> For cordless drills More than 20% battery life time 	56																		
215	Multi-materials	Straight shank		<ul style="list-style-type: none"> Versatile 	57																		
245	Ceramik	Straight shank		<ul style="list-style-type: none"> Drilling of ceramics Speed and cleanliness of drilling 	58																		
208	Hard stone & granit	Straight shank		<ul style="list-style-type: none"> The work of marbrier (installation of kitchen, bathroom...) Durability and resistance 	58																		
400	Ceratile	Straight shank		<ul style="list-style-type: none"> Speed of drilling and great versatility 	59																		
170	Ice	SDS-plus Hexagonal shank		<ul style="list-style-type: none"> Indispensable for drill the ice Installing poles of skiing... 	60																		
201	HPL drill bit	Straight shank		<ul style="list-style-type: none"> Install insulating facade, kitchen, false ceiling... Speed, cleanliness & longevity 	60																		
426	Blue Ceram	Hex		<ul style="list-style-type: none"> Drilling of sandstone Class 4 and 5 Holes clean, precise and without the glare 	50																		
431 432	Diamond core bit	M16		<ul style="list-style-type: none"> Electrical installations (installation of box, box...) Net hole Versatility Robustness 	51																		
326	Carbide core bit	SDS-plus		<ul style="list-style-type: none"> Passage of electrical equipment with diameters important Performance and robustness 	52																		
366	Carbide core bit	SDS-plus		<ul style="list-style-type: none"> Electrical installations requiring drilling diameters very important Performance and robustness 	53																		
300	Carbide core bit	SDS-max		<ul style="list-style-type: none"> Sanitary works and renovation Performance and robustness 	53																		

ATTENTION: the user of our products is the sole responsible for the structural consequences of the drilling of reinforcing rebars. It is necessary to consult specialist engineers if a structural part is concerned.

Optimal Occasional

3 cutters technology



all products 3 cutters technology



Special REINFORCED CONCRETE *booster*_{PLUS} compatible SDS-plus - ref.113



WINDOWS & FRAME drill bit - compatible SDS-plus - ref.102

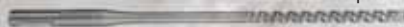

Bit with stop - compatible SDS-plus - ref.108



Special REINFORCED CONCRETE *booster*_{TOP} compatible SDS-top - ref.131

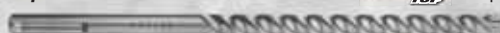

RESISTANCE TO OVERHEATING



The solid monobloc carbide tip, is inserted and brassed with copper, resistant to over 1000°C temperature raise

HAMMERING EFFECT

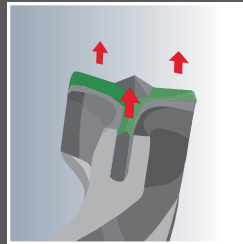

3 135° edges, combine the most efficient drilling without cracking the concrete around

PRECISION

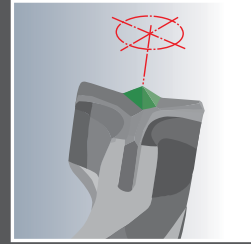

The self centering tip design, drives the bit straight

TRAJECTORY CONTROL

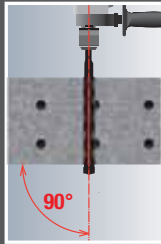

PERFECT HOLE, PERFECT ANCHORING



Answers to all world technical standards agreements

BETTER DUST REMOVAL CAPACITIES

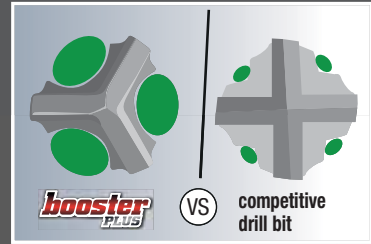

Its design offers the largest dust removal on its marke

SPECIAL REINFORCED CONCRETE

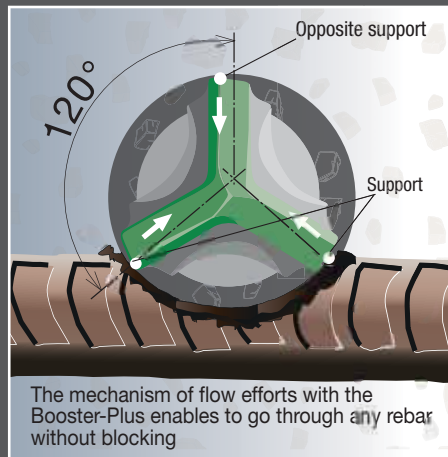

The mechanism of flow efforts with the Booster-Plus enables to go through any rebar without blocking



The drill bit stays straight and keeps its way through.

CONCRETE HAMMER DRILL BIT

Ref.

113



see our
video on
YouTube



3 cutting edges technology



hooster
PLUS

Hammer drill bit compatible SDS-plus

Features

- Monobloc carbide tip with self-centering point.
- Tip angle 135°.
- 3 cutting edges.
- 2 shape designs : Square and Half-round flute.
- Compatible SDS-plus shank.

Benefits

- The 3 cutting edges monobloc tip is the solution for all concrete drilling.
- The self-centering tip allows more precision.
- The tip design guarantees a concentric hole.
- The square flute accelerates dust extraction and improves the drill bit life time.

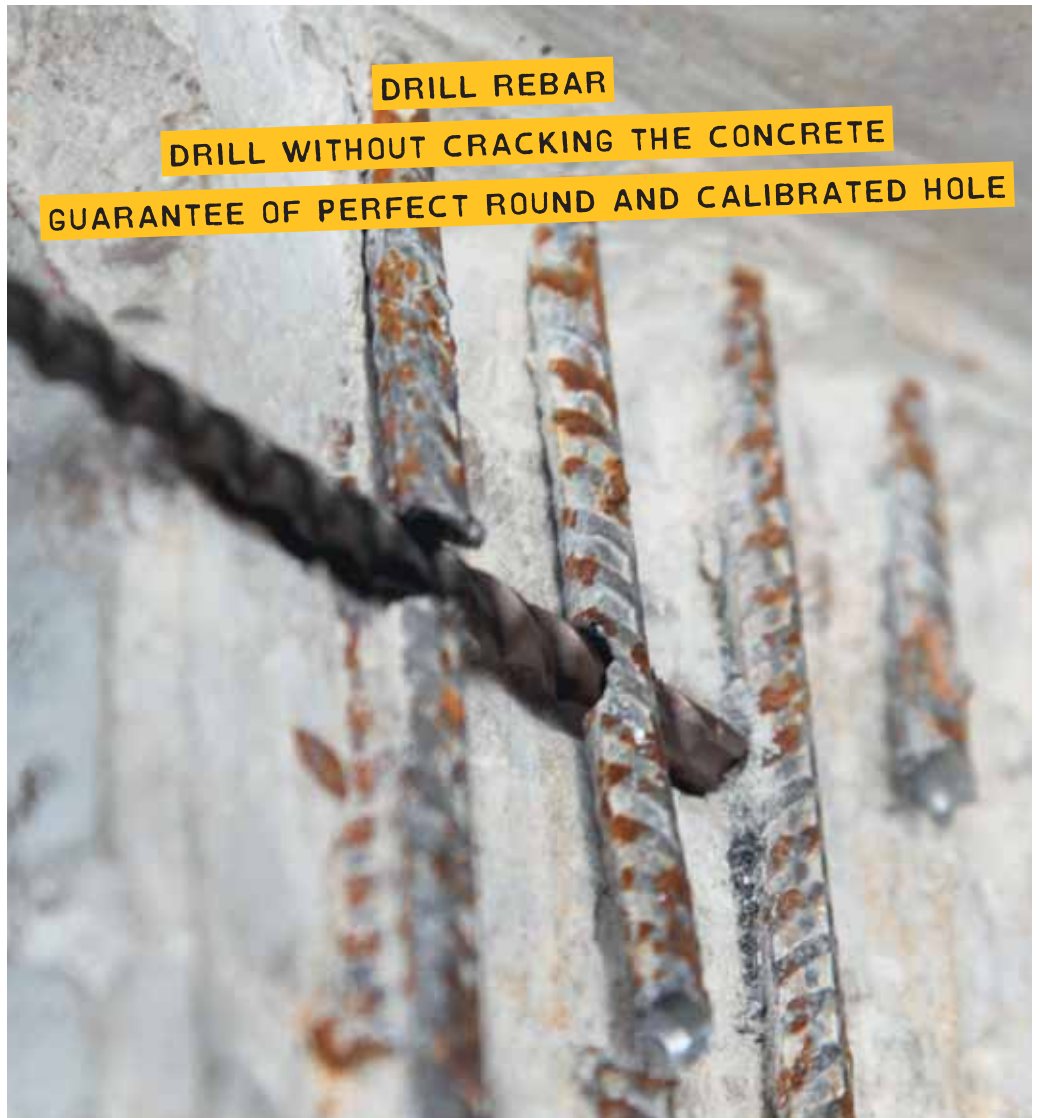

Ø	Ref.	Gencod	Qt.
L 50 x 110			
5	113D05L0110	3336600110694	1
5,5	113D05.5L0110	3336600185791	1
6	113D06L0110	3336600029385	1
6,5	113D06.5L0110	3336600051577	1
7	113D07L0110	3336600077898	1
8	113D08L0110	3336600029392	1
10	113D10L0110	3336600055728	1

Ø	Ref.	Gencod	Qt.
L 100 x 160			
5	113D05L0160	3336600110700	1
5,5	113D05.5L0160	3336600185807	1
6	113D06L0160	3336600029408	1
6,5	113D06.5L0160	3336600051584	1
7	113D07L0160	3336600077904	1
8	113D08L0160	3336600029415	1
9	113D09L0160	3336600093560	1
10	113D10L0160	3336600029422	1
12	113D12L0160	3336600029439	1
13	113D13L0160	3336600093591	1
14	113D14L0160	3336600077911	1
15	113D15L0160	3336600110717	1
16	113D16L0160	3336600110762	1

Ø	Ref.	Gencod	Qt.
L 150 x 210			
5,5	113D05.5L0210	3336600185814	1
6	113D06L0210	3336600029446	1
6,5	113D06.5L0210	3336600093607	1
7	113D07L0210	3336600077928	1
8	113D08L0210	3336600029453	1
9	113D09L0210	3336600093614	1
10	113D10L0210	3336600029460	1
12	113D12L0210	3336600029477	1
13	113D13L0210	3336600093638	1
14	113D14L0210	3336600077935	1
15	113D15L0210	3336600110724	1
16	113D16L0210	3336600084155	1
18	113D18L0210	3336600084162	1
20	113D20L0210	3336600084179	1



Plastic clip
European hole

Ø	Ref.	Gencod	Qt.
L 200 x 260			
6	113D06L0260	3336600154025	1
6,5	113D06.5L0260	3336600154032	1
8	113D08L0260	3336600154049	1
10	113D10L0260	3336600154056	1
12	113D12L0260	3336600154063	1
14	113D14L0260	3336600154070	1
16	113D16L0260	3336600162723	1
18	113D18L0260	3336600162730	1
20	113D20L0260	3336600162747	1

Ø	Ref.	Gencod	Qt.
L 250 x 310			
6	113D06L0310	3336600084186	1
6,5	113D06.5L0310	3336600059443	1
7	113D07L0310	3336600077942	1
8	113D08L0310	3336600029484	1
9	113D09L0310	3336600093645	1
10	113D10L0310	3336600029491	1
12	113D12L0310	3336600029507	1
13	113D13L0310	3336600093676	1
14	113D14L0310	3336600077959	1
15	113D15L0310	3336600110731	1
16	113D16L0310	3336600054264	1
18	113D18L0310	3336600054271	1
20	113D20L0310	3336600054288	1

Ø	Ref.	Gencod	Qt.
L 400 x 460			
8	113D08L0460	3336600093034	1
10	113D10L0460	3336600054295	1
12	113D12L0460	3336600054301	1
14	113D14L0460	3336600054318	1
15	113D15L0460	3336600110748	1
16	113D16L0460	3336600054325	1
18	113D18L0460	3336600054332	1
20	113D20L0460	3336600054349	1

Ø	Ref.	Gencod	Qt.
L 550 x 610			
8	113D08L0610	3336600099173	1
10	113D10L0610	3336600054387	1
12	113D12L0610	3336600054394	1
14	113D14L0610	3336600054400	1
16	113D16L0610	3336600054417	1
18	113D18L0610	3336600054424	1
20	113D20L0610	3336600054431	1



6
PIECES

Ø	Ref.	Gencod	Qt.
L 50 x 110			
6	157KD06L0110	3336600152359	1
L 100 x 160			
6	157KD06L0160	3336600152366	1
8	157KD08L0160	3336600152397	1
10	157KD10L0160	3336600152427	1
14	157KD14L0160	3336600152489	1
16	157KD16L0160	3336600152519	1

Ø	Ref.	Gencod	Qt.
L 150 x 210			
8	157KD08L0210	3336600152403	1
10	157KD10L0210	3336600152434	1
12	157KD12L0210	3336600152465	1
14	157KD14L0210	3336600152496	1
16	157KD16L0210	3336600152526	1
L 250 x 310			
16	157KD16L0310	3336600152533	1

12
PIECES

Ø	Ref.	Gencod	Qt.
L 50 x 110			
5	157LD05L0110	3336600152540	1
6	157LD06L0110	3336600152564	1
8	157LD08L0110	3336600152595	1
L 100 x 160			
5	157LD05L0160	3336600152557	1
6	157LD06L0160	3336600152571	1
8	157LD08L0160	3336600152601	1
10	157LD10L0160	3336600152632	1
12	157LD12L0160	3336600152663	1

Ø	Ref.	Gencod	Qt.
L 150 x 210			
6	157LD06L0210	3336600152588	1
6,5	157LD06.5L0210	3336600164727	1
8	157LD08L0210	3336600152618	1
10	157LD10L0210	3336600152649	1
12	157LD12L0210	3336600152670	1

Ø	Ref.	Gencod	Qt.
L 200 x 260			
6	157LD06L0260	3336600162693	1
8	157LD08L0260	3336600158818	1
10	157LD10L0260	3336600159068	1
12	157LD12L0260	3336600158825	1
16	157LD16L0260	3336600162709	1

Ø	Ref.	Gencod	Qt.
L 250 x 310			
8	157LD08L0310	3336600152625	1
10	157LD10L0310	3336600152656	1
12	157LD12L0310	3336600152687	1

Ø	Ref.	Gencod	Qt.
L 400 x 460			
8	157LD08L0460	3336600183346	1
10	157LD10L0460	3336600159075	1
12	157LD12L0460	3336600159082	1

Ø	Ref.	Gencod	Qt.
L 550 x 610			
10	157LD10L0610	3336600159099	1
12	157LD12L0610	3336600159105	1



OR

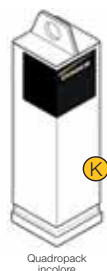

Quadrapack
incoloro

25
PIECES

Ø	Ref.	Gencod	Qt.
L 50 x 110			
5	157MD05L0110	3336600152694	1
6	157MD06L0110	3336600152717	1
8	157MD08L0110	3336600152748	1

Ø	Ref.	Gencod	Qt.
L 100 x 160			
5	157MD05L0160	3336600152700	1
6	157MD06L0160	3336600152724	1
8	157MD08L0160	3336600152755	1
10	157MD10L0160	3336600152786	1
12	157MD12L0160	3336600152816	1

Ø	Ref.	Gencod	Qt.
L 150 x 210			
6	157MD06L0210	3336600152731	1
8	157MD08L0210	3336600152762	1
10	157MD10L0210	3336600152793	1
12	157MD12L0210	3336600152823	1

Ø	Ref.	Gencod	Qt.
L 250 x 310			
8	157MD08L0310	3336600152779	1
10	157MD10L0310	3336600152809	1

Quadrpack
Box of 6, 12 or 25
drills bits

CONCRETE HAMMER DRILL BIT

Ref.
108



for Drop-in-Anchor

3 cutting edges technology



Stop drill bit

Hammer drill bit compatible SDS-plus

Features

- Monobloc carbide tip with self-centering point.
- Tip angle 135°.
- 3 cutting edges.
- Half-round flute.
- Depth stop.
- Compatible SDS-plus shank.

Benefits

- The depth stop allows precise and repetitive control over the drilling depth.
- Precise starting up to avoid the sweep effect.
- One-piece tip with three cutting edges for all types of concrete including reinforced concrete.
- The shape of the head guarantees a perfectly round and sized hole.

Applications

- Fast volume assembly for fixings which require precise and repetitive drilling depth (for drop-in anchors). Installation of stadium seats, cable trays, ventilation system,...



Plastic clip
European hole

Ø	Lt	Ref.	Gencod	Qt.
8	27	108D08L0027	3336600181137	1
10	33	108D10L0033	3336600184381	1
12	43	108D12L0043	3336600184398	1
15	52	108D15L0052	3336600181168	1
15	54	108D15L0054	3336600184404	1

PERFECT FOR FAST VOLUME DRILLING
DEPTH CONTROL

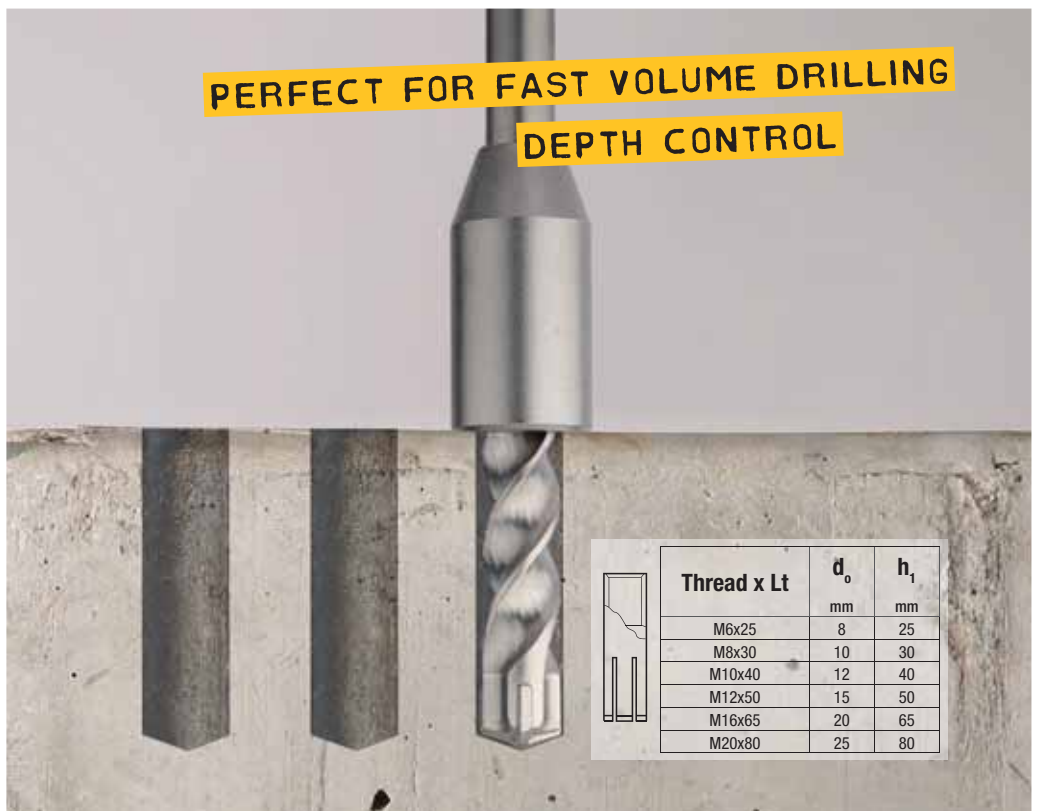

Thread x Lt	d ₀ mm	h ₁ mm
M6x25	8	25
M8x30	10	30
M10x40	12	40
M12x50	15	50
M16x65	20	65
M20x80	25	80

3 cutting edges technology



Special for windows & doors frames

Hammer drill bit compatible SDS-plus

Features

- Monobloc carbide tip with self-centering point.
- Tip angle 135°.
- 3 cutting edges.
- Half-round flute with short shaped length.
- Reinforced body / shank junction.
- Compatible SDS-plus shank.

Benefits

- The monobloc 3 cutting edges tip is the solution for all concrete drilling.
- The self-centering tip permits more precision.
- The tip design guarantees a concentric hole.
- The reinforced body / shank junction permits at the drill bit to keep more elasticity on work.

Applications

- Doors and windows frames application.

Ref. 102

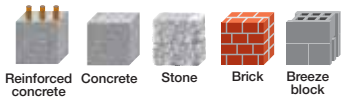

ELASTICITY RESISTANCE

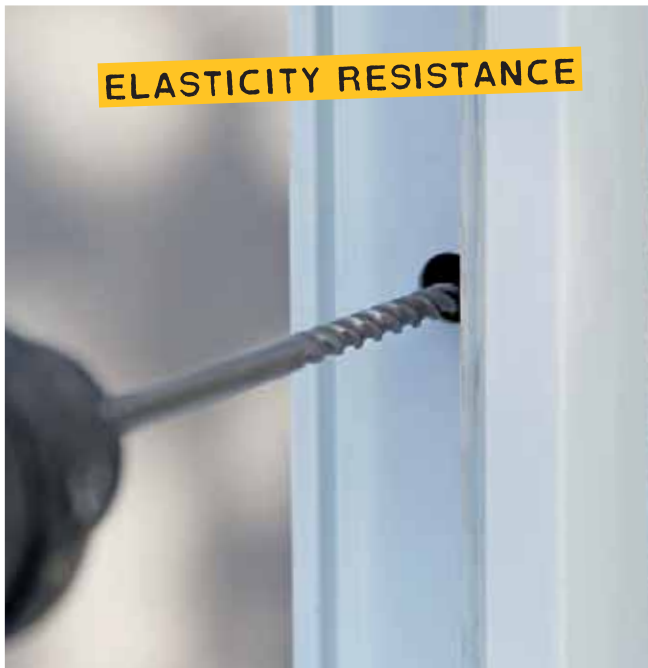

APPLICATIONS

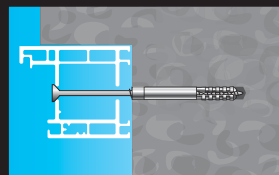
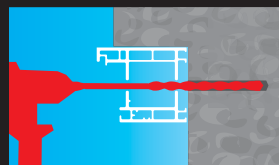

Ø 6 fixing with fastening

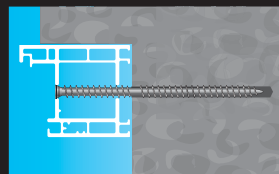

Ø 6.5 fixing with concrete screw

	Ø	Ref.	Gencod	Qt.
 <p>Plastic clip European hole</p>	L 150 x 210			
	6	102D06L0210	3336600157163	1
	6,5	102D06,5L0210	3336600157187	1
	L 200 x 260			
	6	102D06L0260	3336600157170	1
	6,5	102D06,5L0260	3336600157194	1
	L 250 x 310			
	6,5	102D06,5L0310	3336600169586	1

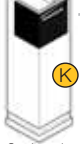
	Ø	Ref.	Gencod	Qt.
 <p>Quadropack Round eyelet</p>	12 PIECES			
	L 200 x 260			
	6,5	103D06,5L0260	3336600162716	1



CONCRETE HAMMER DRILL BIT

Ref.

110

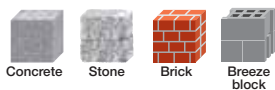

twister² plus

SPEED

LONGER LIFE TIME

Hammer drill bit compatible SDS-plus

Features

- The new tip offers :
 - a centring tip with "Z" geometry.
 - a wave profile with 3 effective supporting points.
- The new flute offers 2 shape designs : half-round and square.
- Compatible SDS-plus shank.

New TRI-ZONE Flute

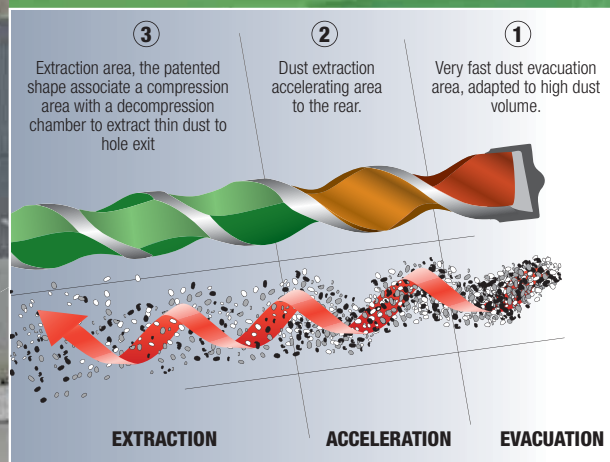

New Carbide Tip

3 CONTACT POINTS

Focus the percussion efforts to the drilling axis. Increase the speed, the destruction power and the accuracy.

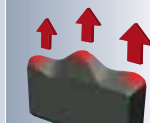

Z FORM SHARP TIP

Chiseling effect and aggressivity increased. High accuracy on the hole starting.



Ø	Ref.	Gencod	Qt.
L 50 x 110			
4	110D04L0110	3336600008359	1
5	110D05L0110	3336600008366	1
5,5	110D05.5L0110	3336600023253	1
6	110D06L0110	3336600008373	1
6,5	110D06.5L0110	3336600023260	1
7	110D07L0110	3336600008380	1
8	110D08L0110	3336600008397	1
10	110D10L0110	3336600008403	1

Ø	Ref.	Gencod	Qt.
L 100 x 160			
4	110D04L0160	33366000067837	1
5	110D05L0160	3336600008410	1
5,5	110D05.5L0160	3336600023277	1
6	110D06L0160	3336600008427	1
6,5	110D06.5L0160	3336600020849	1
7	110D07L0160	3336600008434	1
8	110D08L0160	3336600008441	1
9	110D09L0160	3336600008458	1
10	110D10L0160	3336600008465	1
11	110D11L0160	3336600008472	1
12	110D12L0160	3336600008489	1
13	110D13L0160	3336600008496	1
14	110D14L0160	3336600008502	1
15	110D15L0160	3336600008519	1
16	110D16L0160	3336600008526	1

Ø	Ref.	Gencod	Qt.
L 150 x 210			
5	110D05L0210	3336600076457	1
6	110D06L0210	3336600008533	1
6,5	110D06.5L0210	3336600020856	1
7	110D07L0210	3336600020863	1
8	110D08L0210	3336600008540	1
9	110D09L0210	3336600008557	1
10	110D10L0210	3336600008564	1
11	110D11L0210	3336600030107	1
12	110D12L0210	3336600008571	1
13	110D13L0210	3336600008588	1
14	110D14L0210	3336600008595	1
15	110D15L0210	3336600008601	1
16	110D16L0210	3336600008618	1
17	110D17L0210	3336600008710	1
18	110D18L0210	3336600008625	1
20	110D20L0210	3336600008632	1
22	110D22L0210	3336600008649	1
24	110D24L0210	3336600014817	1
25	110D25L0210	3336600008656	1

Ø	Ref.	Gencod	Qt.
L 200 x 260			
5,5	110D05.5L0260	3336600185647	1
6	110D06L0260	3336600008663	1
6,5	110D06.5L0260	3336600076389	1
7	110D07L0260	3336600021556	1
8	110D08L0260	3336600008670	1
10	110D10L0260	3336600008687	1
12	110D12L0260	3336600008694	1
13	110D13L0260	3336600008700	1
14	110D14L0260	3336600008717	1
15	110D15L0260	3336600008724	1
16	110D16L0260	3336600008731	1
18	110D18L0260	3336600008748	1
20	110D20L0260	3336600008755	1
22	110D22L0260	3336600008762	1
24	110D24L0260	3336600014824	1
25	110D25L0260	3336600008779	1



Plastic clip
European hole

Ø	Ref.	Gencod	Qt.
L 250 x 310			
5	110D05L0310	3336600166189	1
5,5	110D05.5L0310	3336600185654	1
6	110D06L0310	3336600023291	1
8	110D08L0310	3336600023307	1
10	110D10L0310	3336600023314	1
12	110D12L0310	3336600023321	1
13	110D13L0310	3336600054950	1
14	110D14L0310	3336600023338	1
15	110D15L0310	3336600023345	1
16	110D16L0310	3336600023352	1
18	110D18L0310	3336600023369	1
20	110D20L0310	3336600023376	1
22	110D22L0310	3336600023383	1
24	110D24L0310	3336600023390	1
25	110D25L0310	3336600023406	1
26	110D26L0310	3336600164796	1
28	110D28L0310	3336600164826	1

Ø	Ref.	Gencod	Qt.
L 350 x 410			
8	110D08L0410	3336600008786	1
10	110D10L0410	3336600008793	1
12	110D12L0410	3336600008809	1
13	110D13L0410	3336600008816	1
14	110D14L0410	3336600008823	1
16	110D16L0410	3336600008847	1
18	110D18L0410	3336600008854	1
19	110D19L0410	3336600008861	1
20	110D20L0410	3336600008878	1
22	110D22L0410	3336600008885	1
24	110D24L0410	3336600014831	1
25	110D25L0410	3336600008892	1

Ø	Ref.	Gencod	Qt.
L 400 x 460			
6	110D06L0460	3336600119369	1
8	110D08L0460	3336600023413	1
10	110D10L0460	3336600023420	1
12	110D12L0460	3336600023437	1
14	110D14L0460	3336600023451	1
16	110D16L0460	3336600023475	1
18	110D18L0460	3336600023482	1
20	110D20L0460	3336600023505	1
22	110D22L0460	3336600023512	1
24	110D24L0460	3336600023529	1
25	110D25L0460	3336600023536	1
26	110D26L0460	3336600164802	1
28	110D28L0460	3336600164833	1
30	110D30L0460	3336600164857	1

Ø	Ref.	Gencod	Qt.
L 550 x 610			
8	110D08L0610	3336600008908	1
10	110D10L0610	3336600008915	1
12	110D12L0610	3336600008922	1
14	110D14L0610	3336600008946	1
16	110D16L0610	3336600008953	1
18	110D18L0610	3336600008960	1
20	110D20L0610	3336600008977	1
22	110D22L0610	3336600008984	1
24	110D24L0610	3336600027367	1
25	110D25L0610	3336600008991	1
26	110D26L0610	3336600164819	1

Ø	Ref.	Gencod	Qt.
L 940 x 1000			
8	110D08L1000	3336600009004	1
10	110D10L1000	3336600009011	1
12	110D12L1000	3336600009028	1
14	110D14L1000	3336600009035	1
16	110D16L1000	3336600009042	1
18	110D18L1000	3336600009059	1
20	110D20L1000	3336600009066	1
22	110D22L1000	3336600009073	1
25	110D25L1000	3336600009080	1

x7



102C

x4



100C

x5

x7



105D

x35



118B

x22

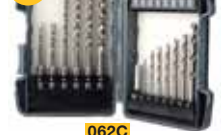

062C

x10

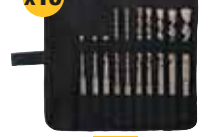

116D

6
PIECES

Ø	Ref.	Gencod	Qt.
L 50 x 110			
6	108KD06L0110	3336600151963	1
L 100 x 160			
6	108KD06L0160	3336600151970	1
8	108KD08L0160	3336600152021	1
16	108KD16L0160	3336600152106	1



Quadropack
European hole

or

50
PIECES

Ø	Ref.	Gencod	Qt.
L 150 x 210			
8	108KD08L0210	3336600152038	1
10	108KD10L0210	3336600152069	1
14	108KD14L0210	3336600152083	1
L 250 x 310			
6	108KD06L0310	3336600151994	1
14	108KD14L0310	3336600152090	1
L 50 x 110			
5	108RD05L0110	3336600152281	1
6	108RD06L0110	3336600152298	1
8	108RD08L0110	3336600182998	1
L 100 x 160			
6	108RD06L0160	3336600152304	1
8	108RD08L0160	3336600152311	1
10	108RD10L0160	3336600152328	1
L 200 x 260			
8	108RD08L0260	3336600168282	1



Quadropack
Round eyelet hole

12
PIECES

Ø	Ref.	Gencod	Qt.
L 50 x 110			
5	108LD05L0110	3336600152113	1
6	108LD06L0110	3336600186873	1
8	108LD08L0110	3336600152168	1
L 100 x 160			
5	108LD05L0160	3336600152120	1
6	108LD06L0160	3336600152137	1
7	108LD07L0160	3336600152151	1
8	108LD08L0160	3336600152175	1
10	108LD10L0160	3336600152205	1
12	108LD12L0160	3336600152229	1
14	108LD14L0160	3336600152250	1

Ø	Ref.	Gencod	Qt.
L 150 x 210			
6	108LD06L0210	3336600152144	1
8	108LD08L0210	3336600152182	1
10	108LD10L0210	3336600152212	1
12	108LD12L0210	3336600152236	1
16	108LD16L0210	3336600152267	1

Ø	Ref.	Gencod	Qt.
L 200 x 260			
6	108LD06L0260	3336600157484	1
8	108LD08L0260	3336600157491	1
10	108LD10L0260	3336600157507	1
12	108LD12L0260	3336600157514	1
14	108LD14L0260	3336600157521	1

Ø	Ref.	Gencod	Qt.
L 250 x 310			
8	1		

CONCRETE MICRO-HAMMERING SYSTEM

Ref.
104

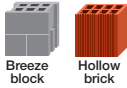

see our
video on
YouTube



WALLSTER

Hammer drill bit compatible SDS-plus

Features

- Semi positive carbide tip.
- Tip angle 130°.
- Short shaped length.
- Elongated pitch.
- Hammering reducer.
- Compatible SDS-plus shank.

Benefits

- The hammering reducer generates micro percussion and keeps the walls of the block safe from damage.
- Calibrated hole.
- Increased anchoring strength.
- The unshaped part of the flute provides rigidity and guides the bit along the line over the entire drilling depth.
- The flute shape makes removal easier while drilling through insulating material.

EFFICIENT IN ALL HOLLOW BLOCKS OF THE MARKET

Slap, breeze block, breeze block Easytherm®, Rubbe, hollow brick, brick for bonding, brick pole, brick rabbet Wienerberger®, plank, brick of arase...

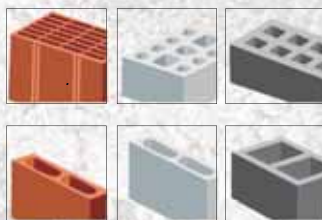

Diager developed specially a bit to drill hollow blocks without degrading walls. This special dill bit for hollow blocks allows to realize qualitative holes which enhance reliability of the anchorings.

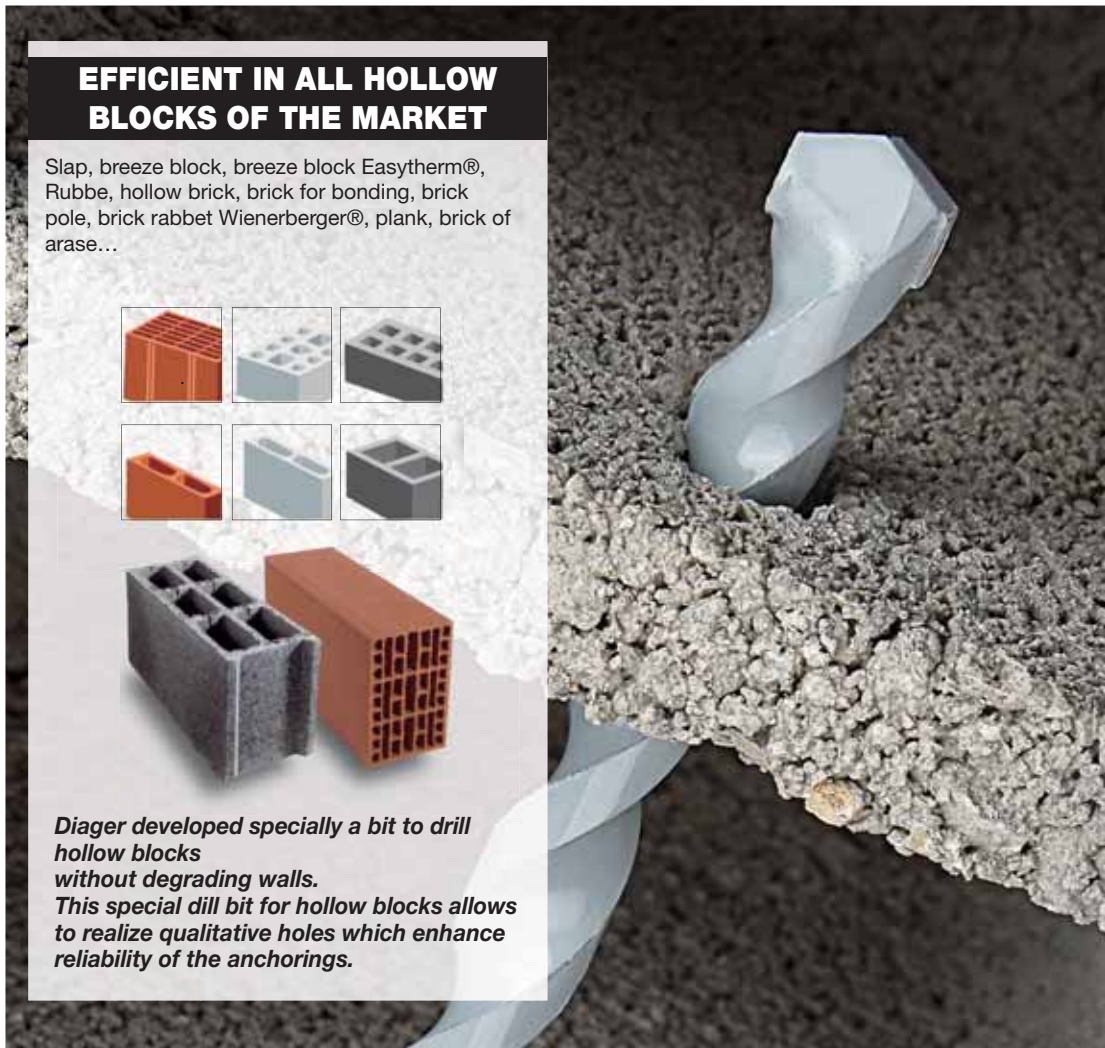

Ø	Ref.	Gencod	Qt.
L 100 x 160			
5	104D05L0160	3336600187214	1
6	104D06L0160	3336600187221	1
8	104D08L0160	3336600187238	1
10	104D10L0160	3336600187245	1
L 200 x 260			
6	104D06L0260	3336600182240	1
8	104D08L0260	3336600182103	1
10	104D10L0260	3336600182110	1
12	104D12L0260	3336600182127	1
14	104D14L0260	3336600182134	1
16	104D16L0260	3336600182141	1
L 400 x 460			
8	104D08L0460	3336600182158	1
10	104D10L0460	3336600182165	1



PLV picking-counter
Delevry unmounted
Ref.C00084

**UP TO 3
TIMES
STRONGER
RESISTANCE**

COMPARATIVE TESTS: DRILLING AND ANCHORING IN A HOLLOW BLOCK

STANDARD Drill bit

Drilling
The wall is damaged, only 7mm thickness remains.

Test of tearing for a chemical fixing
The fixation quickly gives in. Break in 250 kg.

250 Kg
↑
Pull out resistance



Hammer drill WALLSTER

Drilling
The wall is intact, and keeps its original thickness of 16mm.

Test of tearing for a chemical fixing
The fixation resists perfectly. It is the wall which gives in. Break in 700 kg.

700 Kg
↑
Pull out resistance

Tests made with a SDS + machine GBH 2 with hammering in hollow concrete block with a chemical anchor.

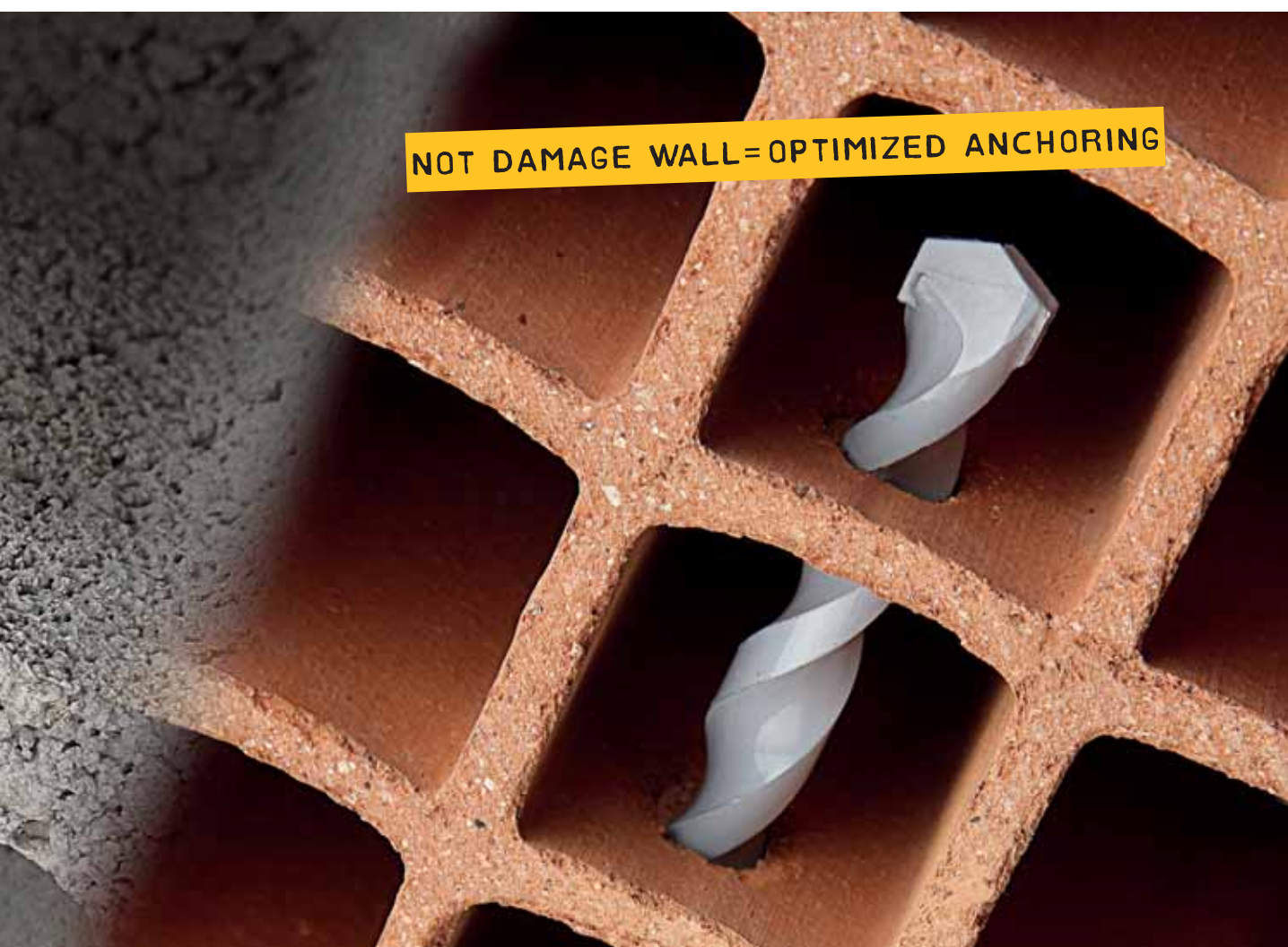

CONCRETE HAMMER DRILL BIT

Ref.
184

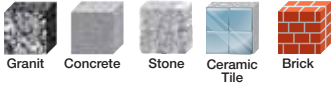

GRANIT

Hammer drill bit compatible SDS-plus

Features

- Special granit profile for the carbide tip.
- Progressive half-round flute.
- Compatible SDS-plus shank.

Benefits

- Drilling into granit from class 1 to 3.



Ø	Ref.	Gencod	Qt.
L 50 x 110			
3	184D03L0085	3336600023802	1
4	184D04L0110	3336600023819	1
5	184D05L0110	3336600022119	1
6	184D06L0110	3336600022126	1
8	184D08L0110	3336600022133	1
10	184D10L0110	3336600023826	1
L 100 x 160			
4	184D04L0160	3336600023833	1
5	184D05L0160	3336600023840	1
6	184D06L0160	3336600022140	1
7	184D07L0160	3336600054714	1
8	184D08L0160	3336600022157	1
10	184D10L0160	3336600022164	1
12	184D12L0160	3336600023857	1
14	184D14L0160	3336600183407	1
16	184D16L0160	3336600183414	1

* Lt. = 85 mm

**DRILLING INTO GRANIT
FROM CLASS 1 TO 3**



SPECIAL ATTACHMENTS

RANGE
ON
REQUEST

Compatible SDS-top



**booster
TOP**

Features

- Monobloc carbide tip with self-centering point.
- Tip angle 135°.
- 3 cutting edges.



**@twister
TOP**

Features

- The new tip offers:
 - a centring tip with "Z" geometry.
 - a wave profile with 3 effective supporting points.



**ULTIMAX
TOP**

Features

- 3 carbide tips with self-centering point.
- 6 cutting edges.
- Progressive flute.

Ref.

131
133



Spline



ULTIMAX

Features

- 3 carbide tips with self-centering point.
- 6 cutting edges.
- Progressive flute.

120



Compatible SDS-plus SPIT®



**@twister
MAGIC PLUS**

Features

- The new tip offers:
 - a centring tip with "Z" geometry.
 - a wave profile with 3 effective supporting points.

111

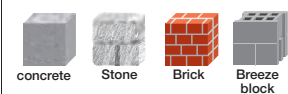

CONCRETE HAMMER DRILL BIT

Ref.

166



ULTIMAX

Hammer drill bit compatible SDS-max

Features

- 3 carbide tips with self-centering point.
- 6 cutting edges.
- Progressive flute.
- Compatible SDS-max shank.

Benefits

- Guarantee of perfect round and calibrated hole.
- Longer life time.
- Avoid risk of blocking.



RESEARCH AND DEVELOPMENT

Resists *Flex*

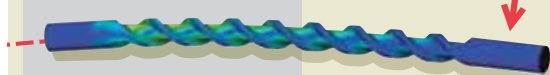

► More Material

Flex exerted in the lower section of a drill bit is the most likely destructive factor. The progressive core of the spiral adds material and increases the rigidity in this area which is subjected to extreme pressure.

Resists *Torsion*

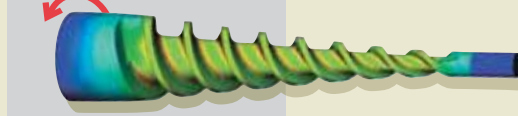

► Anti-blocking System

6 asymmetric cutting edges reduce the risk of blockage when in use on a particularly hard aggregate, or on rebar. The progressive core and the roundness of the flute allow optimal removal of dust and negates any risk of blocking due to dust accumulation.

Resists *Compression*

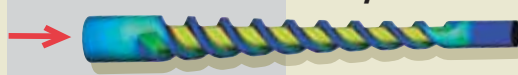

► Heat Treatment

The hardness of concrete combined with the power of the drill unite to create compression. The heat treatment of the body allows the energy of the drill to be concentrated on the tungsten carbide tip (whilst absorbing shock waves).

see our
video on
YouTube





Ø	Ref.	Gencod	Qt.
L 200 x 340			
12	166D12L0340	3336600004818	1
14	166D14L0340	3336600004825	1
15	166D15L0340	3336600004832	1
16	166D16L0340	3336600004849	1
18	166D18L0340	3336600004856	1
20	166D20L0340	3336600004870	1
22	166D22L0340	3336600004887	1
24	166D24L0340	3336600004894	1
25	166D25L0340	3336600004900	1
26	166D26L0340	3336600004917	1
28	166D28L0340	3336600068261	1
30	166D30L0340	3336600028760	1
32	166D32L0340	3336600068278	1
35	166D35L0340	3336600054707	1
36	166D36L0340	3336600063440	1
38	166D38L0340	3336600063457	1
40	166D40L0340	3336600063464	1
42	166D42L0340	3336600063402	1
45	166D45L0340	3336600063471	1

Ø	Ref.	Gencod	Qt.
L 400 x 540			
12	166D12L0540	3336600004924	1
14	166D14L0540	3336600004931	1
15	166D15L0540	3336600004948	1
16	166D16L0540	3336600004955	1
18	166D18L0540	3336600005136	1
20	166D20L0540	3336600005150	1
22	166D22L0540	3336600005167	1
24	166D24L0540	3336600005174	1
25	166D25L0540	3336600005181	1
26	166D26L0540	3336600005198	1
28	166D28L0540	3336600005204	1
30	166D30L0540	3336600005228	1
32	166D32L0540	3336600005235	1
35	166D35L0540	3336600005242	1
36	166D36L0540	3336600005259	1
38	166D38L0540	3336600023093	1
40	166D40L0540	3336600023109	1
42	166D42L0540	3336600023116	1
45	166D45L0540	3336600063419	1

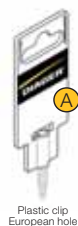

Plastic clip European hole

Ø	Ref.	Gencod	Qt.
L 550 x 690			
16	166D16L0690	3336600005327	1
18	166D18L0690	3336600005334	1
20	166D20L0690	3336600005358	1
22	166D22L0690	3336600005365	1
24	166D24L0690	3336600005372	1
25	166D25L0690	3336600005389	1
26	166D26L0690	3336600005396	1
28	166D28L0690	3336600005402	1
30	166D30L0690	3336600005426	1
32	166D32L0690	3336600005433	1
35	166D35L0690	3336600005440	1
36	166D36L0690	3336600005457	1
38	166D38L0690	3336600028685	1
40	166D40L0690	3336600028692	1
42	166D42L0690	3336600063389	1
45	166D45L0690	3336600063396	1

Ø	Ref.	Gencod	Qt.
L 780 x 920			
16	166D16L0920	3336600005464	1
18	166D18L0920	3336600005471	1
20	166D20L0920	3336600005495	1
22	166D22L0920	3336600005501	1
24	166D24L0920	3336600005518	1
25	166D25L0920	3336600005525	1
26	166D26L0920	3336600005532	1
28	166D28L0920	3336600005549	1
30	166D30L0920	3336600005563	1
32	166D32L0920	3336600005570	1
35	166D35L0920	3336600005587	1
36	166D36L0920	3336600005594	1
40	166D40L0920	3336600005600	1
42	166D42L0920	3336600021464	1
45	166D45L0920	3336600024113	1

Ø	Ref.	Gencod	Qt.
L 1160 x 1300			
20	166D20L1300	3336600063297	1
22	166D22L1300	3336600063303	1
25	166D25L1300	3336600068193	1
28	166D28L1300	3336600063310	1
32	166D32L1300	3336600028746	1
35	166D35L1300	3336600063327	1
36	166D36L1300	3336600063334	1
42	166D42L1300	3336600063341	1
45	166D45L1300	3336600063358	1

Ø	Ref.	Gencod	Qt.
L 1360 x 1500			
20	166D20L1500	3336600024120	1
24	166D24L1500	3336600024137	1
25	166D25L1500	3336600037625	1
28	166D28L1500	3336600024144	1
32	166D32L1500	3336600024151	1
36	166D36L1500	3336600024168	1
40	166D40L1500	3336600063365	1
42	166D42L1500	3336600063372	1
45	166D45L1500	3336600027091	1

* One-tip

NEW SDS-MAX DRILL BIT

ULTIMAX 646

new

100% CARBIDE HEAD - 10 CUTTERS

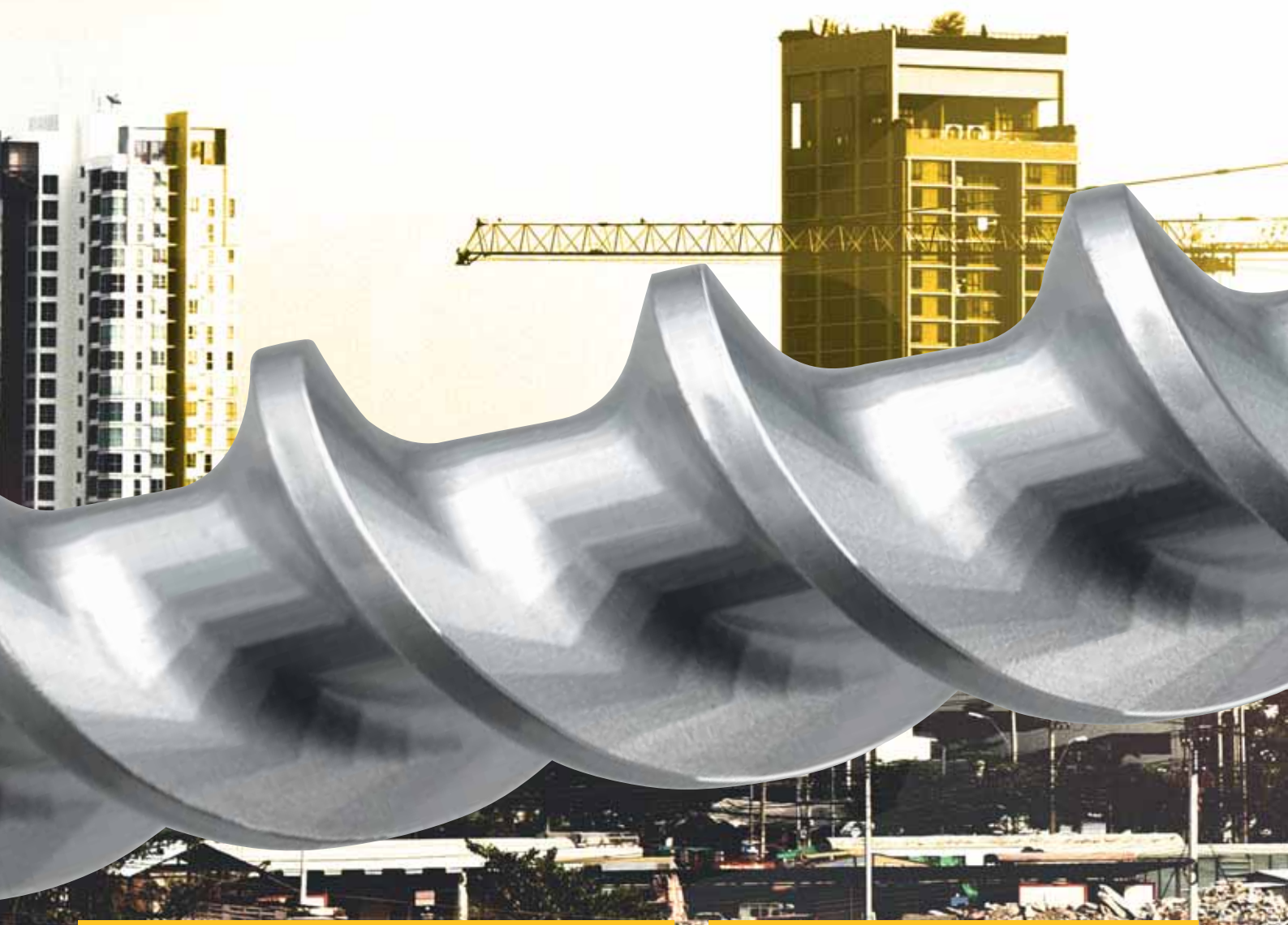

**DRILLS THROUGH
OVERSIZED REBAR***

+ 1000 HOLES*



* Hand tests with 20 joules hammer drill

* Tests on an automatic bench, 8,8 joules hammer drill, C50/60 concrete, 150mm hole depth, 24mm hole diameter

AVAILABLE SECOND HALF 2018

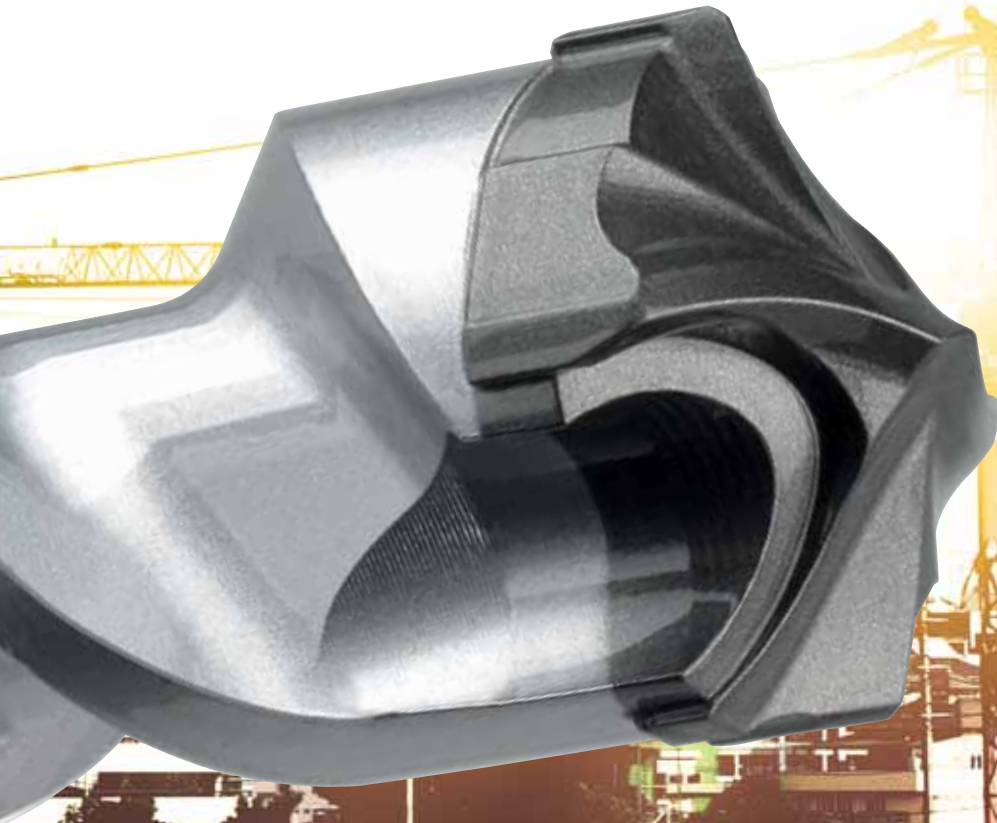

HIGH SPEED DRILLING*

IDEAL FOR POWERFUL HAMMER DRILL



*Tests on an automatic bench, 8,8 joules hammer drill, C50/60 concrete, average on the 300 first holes

CONCRETE DUST FREE DRILL BIT

Ref.
161



SPEEDUSTER 646

Hammer drill bit compatible SDS-max

Features

- 2 wide suction holes of the dust.
- Vacuum cleaner connecting sleeve.
- Head Massiv System, 100% carbure, 10 cutters, self centering tip.
- Reduced drill bit body with center drilling guide according to model.

Benefits

- Work without dust.
- Operators work without risk for their health.
- Drilling and cleaning of the holes and cleaning of the worksite in only one step.
- Time saving on drilling, fastening and worksite cleaning for a better profitability.
- Perfect cleaning of the hole for a very strong fastening resistance.
- The dust evacuation during drilling improves drill bit lifetime.

Applications

- Reinforced concrete, concrete (wet or renovation), stone, masonry blocks, brick, lime.
- Retroactive rebar connection : in structural parts (bridges, tunnels, frame renovation or improvement)
- Drilling in closed rooms, clean spaces, hospitals, laboratories...

Advices

- See notice on our website www.diager.com



CLEAN & SAFE
SAFE FASTENING



see our
video on
YouTube



Connecting sleeve SDS-Max + O'ring



COMPATIBLE PIPES VACUUM Ø 35mm
or with adapter



Ø	Lu	Lt	Ref.	Gencod	Qt.
L 400 x 610					
14	400	610	161D14L0610	3336600192669	1
16	400	610	161D16L0610	3336600192676	1
18	400	610	161D18L0610	3336600192683	1
20	400	610	161D20L0610	3336600192690	1
22	400	610	161D22L0610	3336600192706	1
25	400	610	161D25L0610	3336600192713	1
28	400	610	161D28L0610	3336600192720	1
30	400	610	161D30L0610	3336600192737	1
32	400	610	161D32L0610	3336600192744	1
35	400	610	161D35L0610	3336600192751	1

Connecting sleeve + O'ring SDS-Max

161DMAX

3336600192768

1

* 3 cutters tip

3 CUTTERS TIP
Ø 14-16-18-20



HEAD MASSIVE
SYSTEM

Ø 22-25-28-30-32-35



DUST-FREE DRILL BIT

SPEEDUSTER 646

TARGET : DUST-FREE

SPEEDUSTER dust-free drill bit with the massive head system allows immediate dust extraction.

SPEEDUSTER drills faster and without any blocking, its lifetime is significantly longer.



CLEANER WORKSITE



SPEEDUSTER drills and extracts dust in one stage. Job is done faster. Indoor equipment is safe from dust and lasts longer.

PROTECTION



In compliance with the new international dust exposure regulations, workers are now protected from dust. According to countries, rule establishes the value of exposure to quartz silica (breathable dust) at 0,1 mg / m3 for 8 working hours.

FAST SPEED DRILLING

DRILLS TWICE FASTER

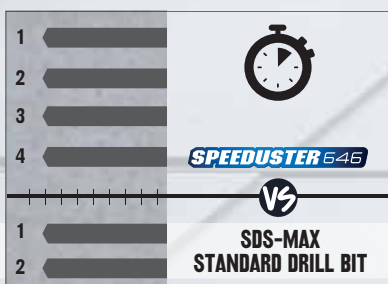

SPEEDUSTER drills 4 holes vs 2 for a standard SDS-Max drill bit.

EFFICIENTLY

FASTENING IN 2 STEPS ONLY

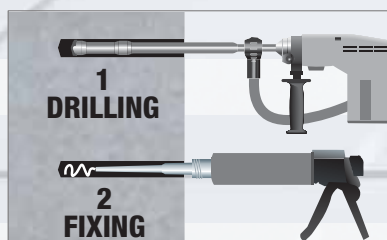

Holes drilling and cleaning are made in a single stage. Chemical fastening resistance is multiplied tenfold thanks to the perfectly clean holes. There are a real time-saving and a bigger profitability of worksites.

DRILLING COMPARISON

SDS-MAX STANDARD DRILL BIT



SPEEDUSTER 646



1KG OF DUST



DUST-FREE



Drilling diameter 32, length 1 meter depth in C50/60 concrete

Tests done in our internal laboratories.

CONCRETE HAMMER DRILL BIT



Power-Max

Hammer drill bit compatible SDS-max

Features

- Adjustable and upgradeable system for deep drilling more than 1m.
- Capacity to adapt head from Ø32 to 80 mm or carbide core bit from Ø30 to 125 mm.
- Head with carbide tip and centering drill bit with 2 cutting edges.

Benefits

- Versatility and modularity.
- Adapts to all Hammerbohrer by changing only the adapter.
- Very strong resistance.
- For all situations of drilling.
- Specially adapted for the drilling of large lengths.

Advices

- Finish to assembly the tool with spanner gripping.
- Regularly lubricate the coupling screws and the threaded bores.
- Put the delivery spring on the femal part (blocking system).

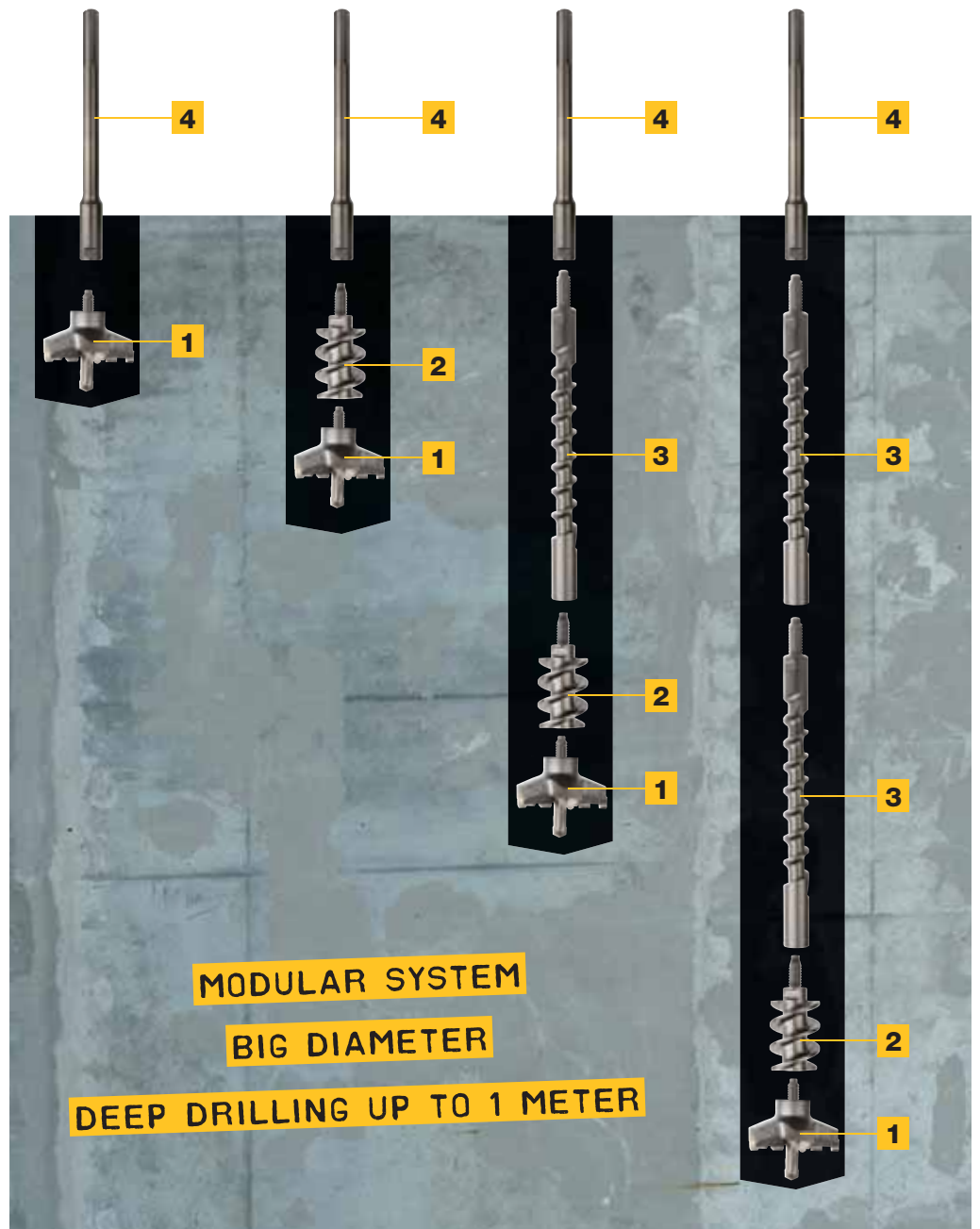

Power-Max head + centering drill bit



Ø	Lt	Ref.	Gencod	Qt.
32	43	373BD32	3336600154094	1
44	43	373BD44	3336600146273	1
52	43	373BD52	3336600143456	1
60	43	373BD60	3336600143463	1
66	43	373BD66	3336600143470	1
80	43	373BD80	3336600143487	1



Twistpack
European hole

Ref.

373B ¹



Power-Max spiral

For	Ø	Lt	Ref.	Gencod	Qt.
Ø44-52	40	180	372BD40	3336600143432	1
Ø60-80	55	90	372BD55	3336600143449	1



Twistpack
Round eyelet

372B ²



Power-Max extension + coupling screw + spring

Ø	Lt	Ref.	Gencod	Qt.
14	280	371BD0280	3336600143425	1



Twistpack
Round eyelet

371B ³



Power-Max adapter compatible SDS-max

Ø	Lt	Ref.	Gencod	Qt.
14	250	370BD0250	3336600143395	1
14	450	370BD0450	3336600143401	1
14	850	370BD0850	3336600143418	1



Plastic clip
European hole

370B ⁴



Centering drill bit for Power-Max head

Ø	Lt	Ref.	Gencod	Qt.
12	90	374B	3336600143494	1

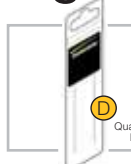

Quality plastic pouch
European hole

374B



Power-Max coupling screw + spring

Ø	Lt	Ref.	Gencod	Qt.
14	62	375B	3336600143500	1



Quality plastic pouch
European hole

375B



Power-Max adapter for core bit

Ø	Lt	Ref.	Gencod	Qt.
26	90	376B	3336600143517	1



Twistpack
European hole

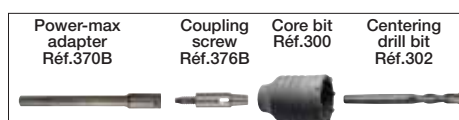

Power-max
adapter
Réf.370B

Coupling
screw
Réf.376B

Core bit
Réf.300

Centering
drill bit
Réf.302

376B



For core bit Ref. 300 p 47

CONCRETE HAMMER DRILL BIT



Ref.

165



Multi-Cutting edges compatible SDS-max

Features

- Centering drill bit with carbide tip.
- 4 carbide tip in the center.
- 6 carbide tip in the periphery.
- Implantation asymmetric of the carbide tip.
- Important area of evacuation of the dust.
- Tapered rod strengthened.
- Long shank (590 ou 990).
- Attachment compatible SDS-max.

Benefits

- Long life.
- Resistance.
- Power of destruction increased.
- Rigidity.
- More lightweight (-20%), best comfort of use.

Applications

- Deep drilling or through.
- Drilling of large diameters up to 80 mm.
- Passage of cable and of tubes and pipes of refurbishment or new construction.



Or



Twistpack
European hole

Ø	Ref.	Gencod	Qt.
L 450 x 590			
45	165D45L0590	3336600098848	1
55	165D55L0590	3336600005297	1
65	165D65L0590	3336600005303	1
80	165D80L0590	3336600005310	1
L 780 x 990			
45	165D45L0990	3336600005617	1
55	165D55L0990	3336600005624	1
65	165D65L0990	3336600005631	1
80	165D80L0990	3336600005648	1

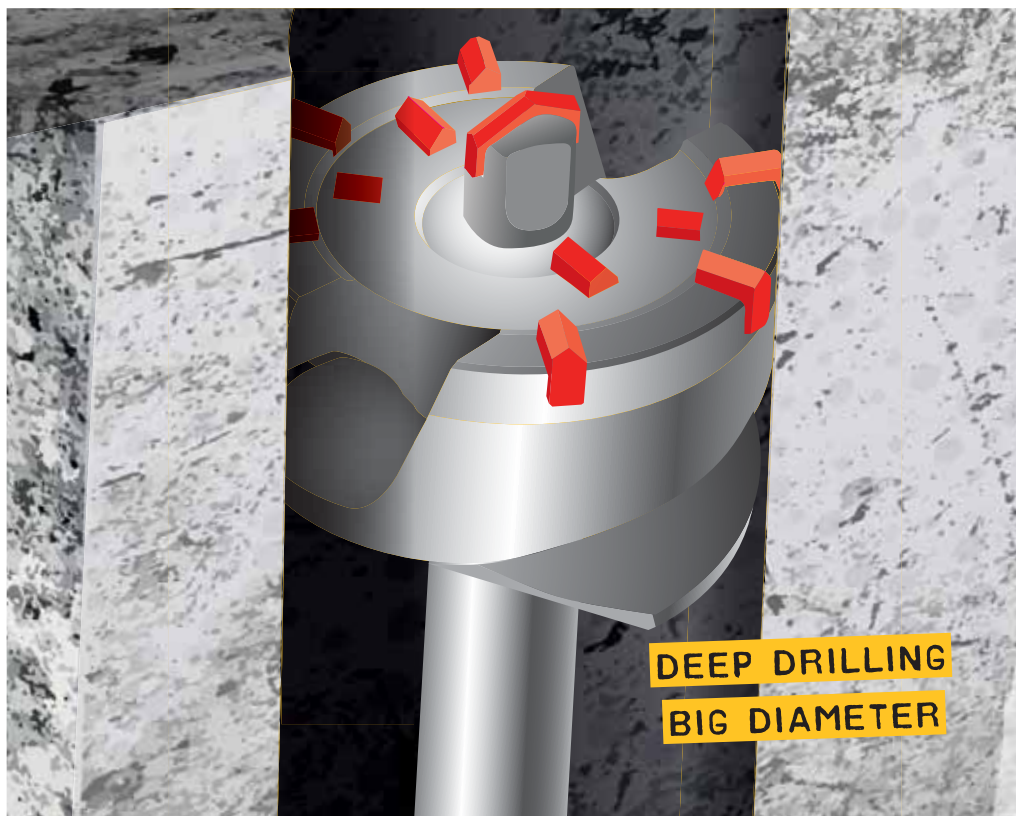

DEEP DRILLING
BIG DIAMETER

Adapter compatible SDS-plus

Ref.
138B



Designation	Ref.	Gencod	Qt.
SDS-max Compatible SDS-plus	138B	3336600015661	1



Adapter thread 1/2"



143B



147B



172B



177B

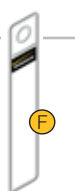

Designation	Ref.	Gencod	Qt.	Pack
SDS-plus 1/2" male*	143B*	3336600063990	1	A
6 pans 1/2" male	147B	3336600167582	1	D
SDS-plus & SPIT 1/2" male	172B	3336600064003	1	D
SDS-max 1/2" male	177B	3336600064010	1	F

*without screw, compatible 121K



CONCRETE ACCESSORIES

Ref.

120K



Chuck

Features

- Hand-tightening keyless chuck.
- Using range : Ø 0,5 - 10 mm.
- 2 plastic sleeves.
- Thread Ø 3/8 x L 24 mm.

121K



Features

- Hand-tightening keyless chuck.
- Using range : Ø 1,5 - 13 mm.
- Locking system.
- 2 plastic sleeves.
- Thread Ø 1/2 x L 20 mm.



Twistpack European tube

Ref.	Gencod	Qt.
120K	3336600144293	1
121K	3336600144309	1

122K

123K



Features

- Key chuck.
- Using range : Ø 1,5 to 13 mm.
- Metal sleeve.
- Thread Ø 1/2 x L 20 mm.



Twistpack European tube



Plastic pouch Round metal eyelet

Ref.	Gencod	Qt.	Pack
122K	3336600144286	1	M
123K	3336600144279	1	E

124K



Chuck for angle grinder



SPECIAL ANGLE GRINDER

Features

- Keyless chuck for grinding machine.
- Using range : Ø 1,5 to 13 mm.
- Locking system.
- 2 metal sleeves.
- Thread M14.



Twistpack European tube

Ref.	Gencod	Qt.
124K	3336600146938	1

DEMOLITION RANGE

- Pointed chisels
 - Flat chisels, angled bolster, jointed chisel
 - Bush hammer Head
 - Concrete, brick chasing chisel
 - Pics spécial brise béton
-
- Hammer drills
 - Electric breaker



Helical pointed chisel

EFFORTLESS DRILLING

ANTI-LOCK

CONCRETE CHISELS

HAMMER DRILL



Ref.

322
323
342
395



Compatible SDS-plus



Compatible SDS-plus & SPIT®



Compatible SDS-max



Compatible SDS-top



Helical pointed

Features

- Helical working head.
- 4 unblocking cutting edges.
- Black flute and sandblasted head.
- Compatible SDS-plus / SDS-max / SDS-top / SDS-plus & SPIT shank.

Ø	Lt	Ref.	Gencod	Qt.	Pack
Compatible SDS-plus					
12	250	322D12L0250	3336600012820	1	A
14	250	322D14L0250	3336600022171	1	A
Compatible SDS-plus & SPIT					
14	250	323D14L0250	3336600012288	1	H
Compatible SDS-max					
18	280	342D18L0280	3336600063488	1	A
18	400	342D18L0400	3336600061521	1	A
18	600	342D18L0600	3336600063495	1	A
NEW 18	750	342D18L0750	3336600174238	1	A
Compatible SDS-top					
14	270	395D14L0270	3336600083189	1	H

*On request

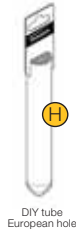

ALL SETS
PAGES 62-63



111C 315C

Compatible SDS-plus Ref. 111C
Compatible SDS-max Ref. 315C

HELICAL WORKING HEAD

4 UNBLOCKING CUTTING EDGES

HELICAL WORKING PROFIL



EFFORTLESS DRILLING

Due to its helical head, the pointed chisel penetrates and expels easily more materials. The user's efforts are minimised in comparison to a classic head form. User comfort is improved.

ANTI-LOCK

The new helical working head works in half rotation with constant pressure on its 4 cutting edges. Due to its guide and specific geometry which air and dust removal during drilling, it doesn't lock into materials.

100% POWERFULL

High temperature heat treatment under controlled atmospheric conditions provides maximum strength which concentrates all the hammer power for a real chiseling performance.



318
319
343
396



Flat chisel

Larg.	Lt	Ref.	Gencod	Qt.	Pack
Compatible SDS-plus					
20	250	318L20L0250	3336600063518	1	A
40	200	318L40L0200	3336600063525	1	A
Compatible SDS-plus & SPIT					
20	250	319L20L0250	3336600063532	1	H
Compatible SDS-max					
24	280	343L24L0280	3336600063549	1	A
24	400	343L24L0400	3336600061514	1	A
24	600	343L24L0600	3336600075368	1	A
50	360	343L50L0360	3336600063556	1	A
80	300	343L80L0300	3336600063563	1	A
115	350	343L115L0350	3336600063570	1	A
Compatible SDS-top					
20	270	396L20L0270	3336600083127	1	F
40	250	396L40L0250	3336600083134	1	F
60	250	396L60L0250	3336600083141	1	F

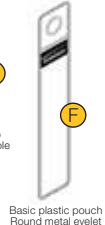

Bush hammer head

Features

- 16 Carbide Teeth.
- Monobloc.



Twistpack
European tube

Larg.	Lt	Ref.	Gencod	Qt.
Compatible SDS-max				
45	240	363D16L0045	3336600063723	1

Ref.
363

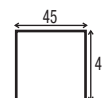

Angled bolster

Applications

For bigger breaking work with an ergonomical angled chisel.



Basic plastic pouch
Round metal eyelet



Plastic clip
European hole

Larg.	Lt	Ref.	Gencod	Qt.	Pack
Compatible SDS-plus					
40	200	348L40L0200	3336600063648	1	A
NEW 80	200	348L80L0200	3336600192430	1	A
Compatible SDS-max					
50	300	349L50L0300	3336600063655	1	A
80	300	349L80L0300	3336600185401	1	A
Compatible SDS-top					
40	250	397L40L0250	3336600083110	1	F

348
349
397



Toothed chisel

Applications

To unjoint brick, stone, tiles and roughcast.



Plastic clip
European hole

Larg.	Lt	Ref.	Gencod	Qt.
Compatible SDS-max				
38	280	361L40L0280	3336600063662	1

361



Jointed chisel

Applications

To put out the junctions mortar of bricks...



Plastic clip
European hole

Ep.	Lt	Ref.	Gencod	Qt.
Compatible SDS-max				
10	300	329L10L0300	3336600063679	1

329



Concrete chasing chisel

Applications

To make thick trench on concrete.



Plastic clip
European hole

Ø	Lt	Ref.	Gencod	Qt.
Compatible SDS-plus				
22	250	311L22L0250	3336600063686	1
Compatible SDS-max				
26	300	312L26L0300	3336600063693	1

311
312



Brick chasing chisel

Applications

For jobs in standstone, stone and brick. Ideal for varying the depth of the channel glides through and digging locations for distribution boxes and sockets without changing tools.



Plastic clip
European hole

ØxP.	Lt	Ref.	Gencod	Qt.
Compatible SDS-max				
32x23	300	314L32L0300	3336600063709	1
35x36	380	314L35L0380	3336600063716	1

314



Ø 32 Ø 35 39

CONCRETE CHISELS / ELECTRIC BREAKER

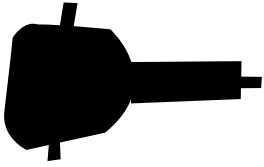

Ref.

310
324
359
354
393



Hexagonal 19 mm
+ retaining groove **NEW**



Hexagonal 19 mm
+ cylindrical tip Ø16,5x35 mm



Hexagonal 22 mm
+ 6 grooves (TE-S)



Hexagonal 28 mm
+ flat



Hexagonal 30 mm
+ cylindrical tip Ø24x55 mm



Pointed chisel

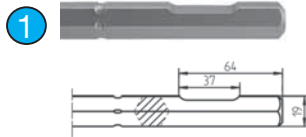

Ø	Lt	Ref.	Gencod	Qt.	Pack
Hexagonal 19 mm + retaining groove*					
19	400	310H19L0400	3336600190306	1	W

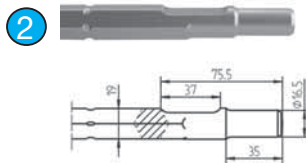

Ø	Lt	Ref.	Gencod	Qt.	Pack
Hexagonal 19 mm + cylindrical tip Ø 16.5x35 mm*					
19	300	324H19L0300	3336600013148	1	H
19	400	324H19L0400	3336600013155	1	H

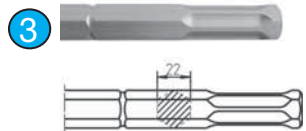

Ø	Lt	Ref.	Gencod	Qt.	Pack
Hexagonal 22 mm + 6 grooves (TE-S)*					
22	360	359D22L0360	3336600173392	1	N

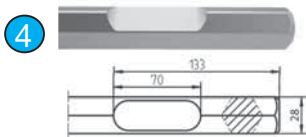

Ø	Lt	Ref.	Gencod	Qt.	Pack
Hexagonal 28 mm + flat					
28	400	354H28L0400	3336600171848	1	M

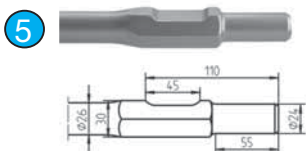

Ø	Lt	Ref.	Gencod	Qt.	Pack
Hexagonal 30 mm + cylindrical tip Ø 24x55 mm					
24	400	393D24L0400	3336600083233	1	H

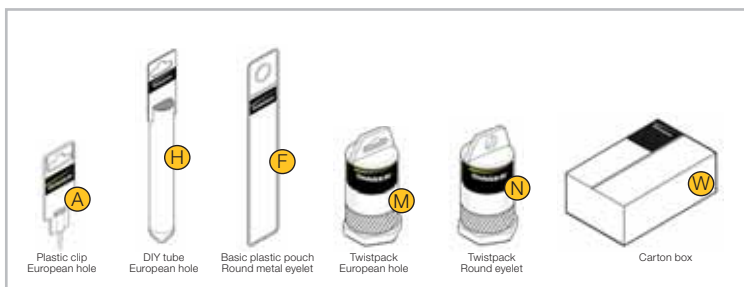

Flat chisel

Ref.

347
320
355
341
394



Made in Germany

1		NEW	Hexagonal 19 mm + gorge de retenue*					
		Ø	Lt	Ref.	Gencod	Qt.	Pack	
		24	400	347L24L0400	3336600190313	1	W	
2		Hexagonal 19 mm + cylindrical tip Ø 16.5x35 mm*						
		Ø	Lt	Ref.	Gencod	Qt.	Pack	
		24	300	320L24L0300	3336600063587	1	H	
		24	400	320L24L0400	3336600063594	1	H	
		80	300	320L80L0300	3336600063617	1	W	
3		Hexagonal 22 mm + 6 grooves (TE-S)*						
		Ø	Lt	Ref.	Gencod	Qt.	Pack	
		28	360	355L28L0360	3336600173408	1	N	
4		Hexagonal 28 mm + flat						
		Ø	Lt	Ref.	Gencod	Qt.	Pack	
		32	400	341L32L0400	3336600173385	1	M	
5		Hexagonal 30 mm + cylindrical tip Ø 24x55 mm						
		Ø	Lt	Ref.	Gencod	Qt.	Pack	
		32	400	394L32L0400	3336600083219	1	H	
		75	400	394L75L0400	3336600083202	1	W	

* On request

Hardware compatibility

	Shank	Engine	Item NB
1		Atlas Copco	PB14D
		Bosch	HS110 (12312) - USH10 (11305)
		Casals	Tornado
		DeWalt	D25940K - D25941K - DW558K
		Elu	SH60K
		Hitachi	DH50SH1 - H45FRV
		Kango	1400B - 638S - 800S - 900B - 900KS - 900S - 900XS - 950B
		Makita	HM1200B
		Milwaukee	5335
		Ryobi	CH465K - CH486K
		Spit	400 - 400S
2		Atlas Copco	PB10H - PH11H - PH5H - PHE50H - PHE5H - PHE6H
		Bosch	GBH7-45DE (11214) - UBH12-50 (11209) - UBH6-35 - UBH6-35D - USH6
		Hitachi	DH38YA - DH38YF - DH40FA - DH40FB - DH40FR - DH50SB - DH50SBK
		Makita	HM0810B - HM1140C - HM1242C - HR3520B - HR3850B - HR4040C - HR5000
		Metabo	Bh1130S - Bh1131S - BhE6030S - RH66 - RH99 - RH99X
		Milwaukee	5311 - 5312 - 5316 - 5317 - 5343 - 5344 - 5347 - 5348 - 5352 - 5353 - PH11H - PH40H
		Wacker	EHBT1BLS
3		Hitachi	TE805 - TE905 - TE905AVR - TE1000AVR - TE1500AVR
4		Bosch	GSH16-28 - GSH27 - GSH27VC - HSH28 (12314) - USH27 (11304)
		DeWalt	D25960K - D25980 - D25980K
		Hitachi	TE3000AVR
		Hitachi	H65 SD - H70 SD - H85 - H90 SE
		Makita	HM1303B - HM1304B - HM1317CB - HM1500B - HM1800 - HM1801 - HM1810
		Bosch	GSH16-30
		Hitachi	H65SB - H65SB2 - H70SA
5		Makita	8900N - HM1300 - HM1303 - HM1304 - HM1317C - HM1400 - HM1500

Hammers drills & attachments compatibility

		ATTACHMENT					
		SDS-plus	SDS-max	SDS-top	Hex19 + Ø16,5	H28	H22 + MEPLAT TES H30 + Ø24x55
BOSCH®	GBH 11 DE		•				
	GBH 2-20 D	•					
	GBH 2-24 D / DF	•					
	GBH 2-28 DFV / DV	•					
	GBH 3-28 DFR / DRE	•					
	GBH 36 VF-LI / V-LI /Compac	•					
	GBH 4-32 DFR	•					
	GBH 5-38 D		•				
	GBH 5-40 DCE		•				
	GBH 7-46 DE		•				
	GB H 8-45 DV		•				
	GBH18V-LI	•					
	GSH 11 E / VC		•				
	GSH 16-28					•	
	GSH 16-30					•	
	GSH 27 VC					•	•
	GSH 3 E	•					
	GSH 388		•				
GSH 5 CE		•					
DEWALT®	D25012K	•					
	D25013C / K	•					
	D25123K	•					
	D25124K	•					
	D25223K	•					
	D25323K	•					
	D25324K	•					
	D25325K	•					
	D25330K	•	•				
	D25404K	•					
	D25405K	•					
	D25501K	•					
	D25601K	•					
	D25712K	•					
	D25762K	•					
	D25831K	•					
	D25870K	•					
	D25899K	•					
	D25901K	•					
	D25980 / K					•	
DC212KA	•						
DC213KB / KL	•						
DC222KA	•						
DC223KA	•						
DC224KA	•						
DC234KL	•						
DC235KL	•						
HILTI®	TE 1	•					
	TE 1000-AVR					•	
	TE 1500-AVR					•	
	TE 2-A22 / M / S	•					
	TE 3000-AVR					•	
	TE 300-AVR	•		•			
	TE 30-A36 / C-AVR / M-AVR	•					
	TE 30-C-AVR / TE 30-M-AVR		•				
	TE 40-AVR		•				
	TE 4-A22	•					
	TE 500-AVR		•				
	TE 50-AVR		•				
	TE 60-ATC		•				
	TE 6-A36-AVR	•					
	TE 7	•					
	TE 700-AVR		•				
	TE 70-ATC		•				
	TE 7-C	•					
	TE 805						•
	TE 80-ATC-AVR		•				

		ATTACHMENT					
		SDS-plus	SDS-max	SDS-top	Hex19 + Ø16,5	H28	H22 + MEPLAT TES H30 + Ø24x55
HITACHI®	DH22PH	•					
	DH24 PB3 / PC / PC3 / PM	•					
	DH25PV	•					
	DH28PC / PD	•					
	DH30PC2	•					
	DH38MS		•				
	DH40 MRY		•				
	DH45MR		•				
	DH50 MRY		•				
	DH50SBK		•		•		
	H45MRY		•				
	H60MR		•				
	H65SB / SB2						•
	H70SA / 70SD						•
	H90SC						
MAKITA®	BHR162RFE	•					
	BHR202RFE / 202Z	•					
	BHR243RFE / 243RFEV / 243RFJ	•					
	BHR261TDP1	•					
	HK1820 / 1820L	•					
	HM0870C		•				
	HM0871C		•				
	HM1111C		•				
	HM1203C		•				
	HM1213C		•				
	HM1214C		•				
	HM1317C						•
	HM1400						•
	HM1810					•	
	HR1830	•					
	HR2230	•					
	HR2300X9	•					
	HR2310TSP1	•					
	HR2432	•					
	HR2460 / 2460F	•					
	HR2470 / 2470F / 2470FT / 2470T-1 / 2470TX1	•					
	HR2600X9	•					
	HR2610TX4	•					
	HR2611FTX4	•					
	HR2811FT	•					
HR3200C	•						
HR3210FCT	•						
HR3541FCX		•					
HR4001C		•					
HR4010C		•					
HR4011C		•					
HR4501C		•					
HR4510C		•					
HR4511C		•					
HR5201C		•					
HR5210C		•					
HR5211C		•					
MILWAUKEE®	545 S	•					
	750 S	•					
	900 S	•					
	950 S	•					
	PCE 3						
	PFH 26	•					
	PH 26	•					
	PH 28 / 28 X	•					
	PLH 20	•					
	PLH 26 E	•					
SPIT®	321	•					
	322	•					
	323	•					
	330	•					
	332	•					
	343	•					
	353	•					
	372	•					
	390	•					
	431	•					
453	•						
490	•						
328EVO+	•						
329C	•						

Core drilling manual Selecting tools

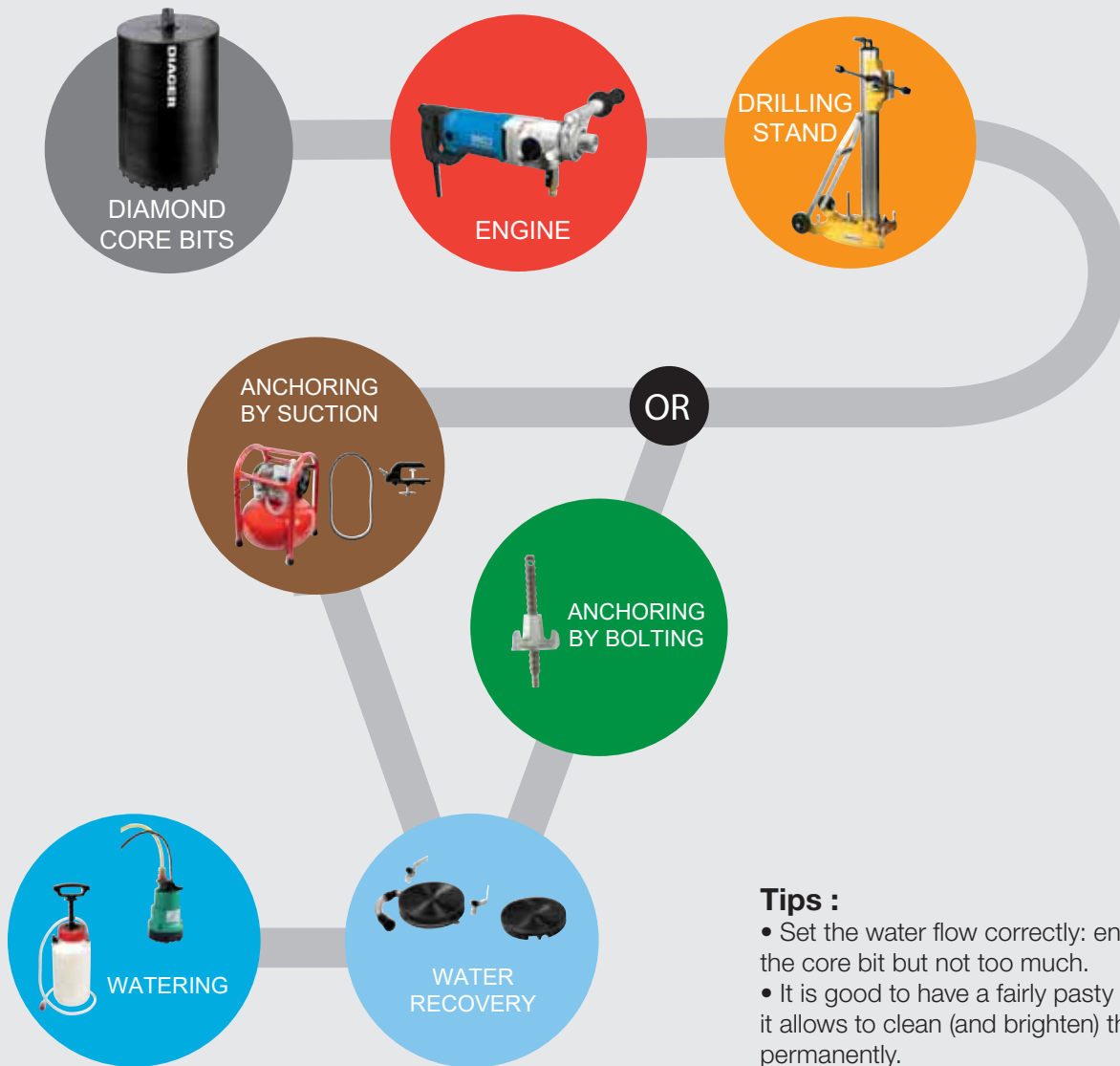

Tips :

- Set the water flow correctly: enough to cool the core bit but not too much.
- It is good to have a fairly pasty water because it allows to clean (and brighten) the segments permanently.
- Regularly chew the segments of the core bit.

Hardware compatibility

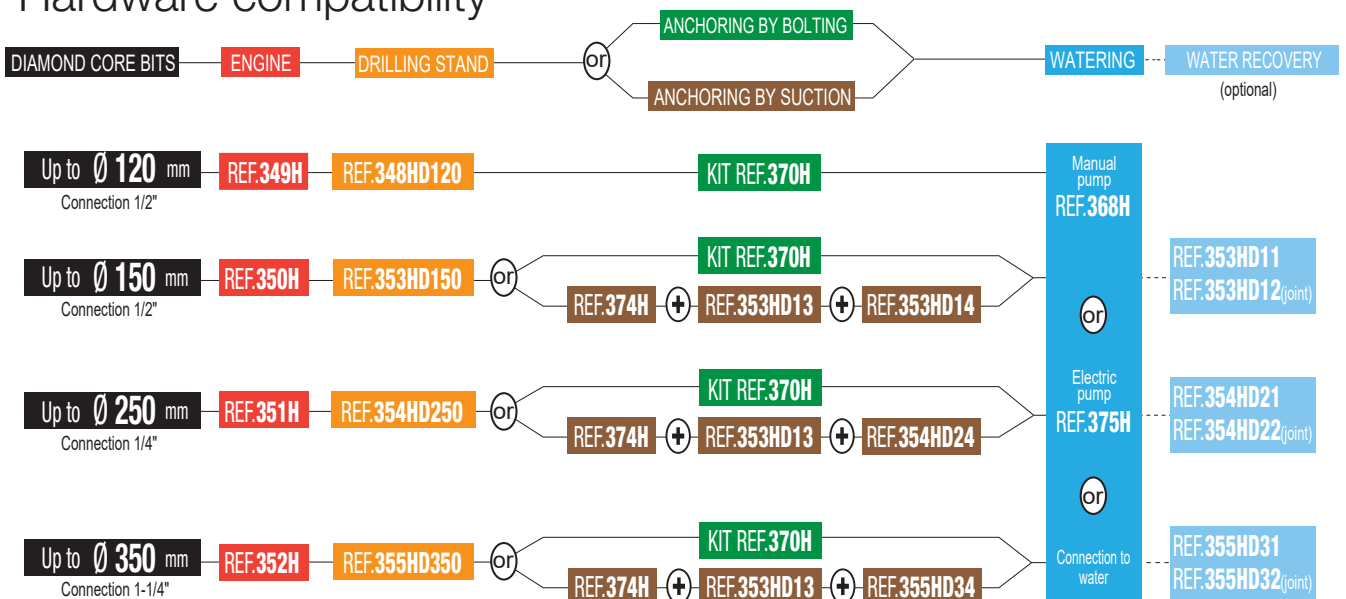

CONCRETE DIAMOND CORE BIT

3 TIMES MORE HOLES

TWICE LESS WEAR

Ref.
436

Hard materials and abrasive concretes

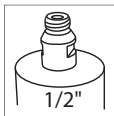
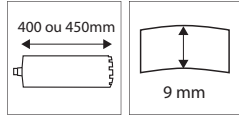

Features

- New segments are more resistant.
- They have 2 times more diamond.
- New segments are made with titan coated diamond which allows smooth and effective work and makes lifetime longer.

Benefits

- Drill rebar.
- Corrugated segments :
 - better evacuation of rubble.
 - less effort for the machine and for the user.
- Open segments :
 - Crown ready for use.
- Forsheda® seal.

Applications

- For passing electrical cable ducts, water or evacuation pipes, ventilation duct,...

439B

Special asphalt

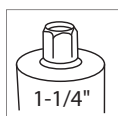
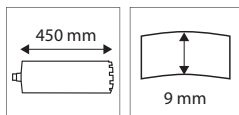

Applications

- Special asphalt core bit.
- Powerful machines.

Ø	N.S.	Lu	Ref.	Gencod	Qt.	Ref.	Qt.
436A		Connection 1/2"		Lu 400		segment reloading	
30	4	400	436AD030L0400	3336600158238	1	RESEGM436D030	1
35	5	400	436AD035L0400	3336600144965	1	RESEGM436D035	1
40	5	400	436AD040L0400	3336600144972	1	RESEGM436D040	1
46	6	400	436AD046L0400	3336600144989	1	RESEGM436D046	1
51	5	400	436AD051L0400	3336600174627	1	RESEGM436D051	1
56	5	400	436AD056L0400	3336600173927	1	RESEGM436D056	1
61	6	400	436AD061L0400	3336600159143	1	RESEGM436D061	1
66	6	400	436AD066L0400	3336600174665	1	RESEGM436D066	1
71	6	400	436AD071L0400	3336600174146	1	RESEGM436D071	1
82	8	400	436AD082L0400	3336600174566	1	RESEGM436D082	1
87	8	400	436AD087L0400	3336600176553	1	RESEGM436D087	1
92	8	400	436AD092L0400	3336600174542	1	RESEGM436D092	1
102	10	400	436AD102L0400	3336600174528	1	RESEGM436D102	1
112	10	400	436AD112L0400	3336600158832	1	RESEGM436D112	1
127	11	400	436AD127L0400	3336600168206	1	RESEGM436D127	1
132	12	400	436AD132L0400	3336600174535	1	RESEGM436D132	1
152	12	400	436AD152L0400	3336600175075	1	RESEGM436D152	1
162	13	400	436AD162L0400	3336600174559	1	RESEGM436D162	1
169	14	400	436AD169L0400	3336600175853	1	RESEGM436D169	1
200	14	400	436AD200L0400	3336600173477	1	RESEGM436D200	1

Ø	N.S.	Lu	Ref.	Gencod	Qt.	Ref.	Qt.
436B		Connection 1-1/4"		Lu 400		segment reloading	
46	7	450	436BD046L0450	3336600174405	1	RESEGM436D046	1
51	5	450	436BD051L0450	3336600144996	1	RESEGM436D051	1
56	6	450	436BD056L0450	3336600145009	1	RESEGM436D056	1
61	6	450	436BD061L0450	3336600145016	1	RESEGM436D061	1
66	7	450	436BD066L0450	3336600145023	1	RESEGM436D066	1
71	8	450	436BD071L0450	3336600145030	1	RESEGM436D071	1
76	8	450	436BD076L0450	3336600145047	1	RESEGM436D076	1
82	8	450	436BD082L0450	3336600145054	1	RESEGM436D082	1
87	10	450	436BD087L0450	3336600145061	1	RESEGM436D087	1
92	10	450	436BD092L0450	3336600145078	1	RESEGM436D092	1
102	10	450	436BD102L0450	3336600145085	1	RESEGM436D102	1
112	10	450	436BD112L0450	3336600145092	1	RESEGM436D112	1
117	10	450	436BD117L0450	3336600145108	1	RESEGM436D117	1
122	11	450	436BD122L0450	3336600145115	1	RESEGM436D122	1
127	11	450	436BD127L0450	3336600145122	1	RESEGM436D127	1
132	12	450	436BD132L0450	3336600145139	1	RESEGM436D132	1
142	12	450	436BD142L0450	3336600145146	1	RESEGM436D142	1
152	13	450	436BD152L0450	3336600145153	1	RESEGM436D152	1
162	13	450	436BD162L0450	3336600145160	1	RESEGM436D162	1
169	13	450	436BD169L0450	3336600154186	1	RESEGM436D169	1
172	13	450	436BD172L0450	3336600145177	1	RESEGM436D172	1
182	13	450	436BD182L0450	3336600145184	1	RESEGM436D182	1
187	14	450	436BD187L0450	3336600154551	1	RESEGM436D187	1
196	13	450	436BD196L0450	3336600154568	1	RESEGM436D196	1
200	15	450	436BD200L0450	3336600145191	1	RESEGM436D200	1
212	14	450	436BD212L0450	3336600154575	1	RESEGM436D212	1
225	15	450	436BD225L0450	3336600145207	1	RESEGM436D225	1
226	15	450	436BD226L0450	3336600154582	1	RESEGM436D226	1
248	16	450	436BD248L0450	3336600154599	1	RESEGM436D248	1
250	18	450	436BD250L0450	3336600145214	1	RESEGM436D250	1
266	16	450	436BD266L0450	3336600154605	1	RESEGM436D266	1
275	18	450	436BD275L0450	3336600145221	1	RESEGM436D275	1
277	18	450	436BD277L0450	3336600154612	1	RESEGM436D277	1
297	24	450	436BD297L0450	3336600154629	1	RESEGM436D297	1
300	24	450	436BD300L0450	3336600145238	1	RESEGM436D300	1
342	24	450	436BD342L0450	3336600154636	1	RESEGM436D342	1
350	26	450	436BD350L0450	3336600145245	1	RESEGM436D350	1
353	24	450	436BD353L0450	3336600154643	1	RESEGM436D353	1
400	26	450	436BD400L0450	3336600145252	1	RESEGM436D400	1
405	26	450	436BD405L0450	3336600187405	1	RESEGM436D405	1

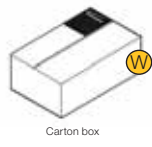

Ø	N.S.	Lu	Ref.	Gencod	Qt.	Ref.	Qt.
439B		Connection 1-1/4"		Lu 400		segment reloading	
82	9	450	439BD082L0450	3336600158849	1	RESEGM439D082	1
92	10	450	439BD092L0450	3336600158856	1	RESEGM439D092	1
102	11	450	439BD102L0450	3336600158863	1	RESEGM439D102	1
112	12	450	439BD112L0450	3336600158870	1	RESEGM439D112	1
122	13	450	439BD122L0450	3336600157668	1	RESEGM439D122	1
127	13	450	439BD127L0450	3336600158887	1	RESEGM439D127	1
132	14	450	439BD132L0450	3336600158894	1	RESEGM439D132	1
142	15	450	439BD142L0450	3336600158900	1	RESEGM439D142	1
152	16	450	439BD152L0450	3336600157415	1	RESEGM439D152	1
162	17	450	439BD162L0450	3336600158917	1	RESEGM439D162	1
172	18	450	439BD172L0450	3336600158924	1	RESEGM439D172	1
182	19	450	439BD182L0450	3336600158931	1	RESEGM439D182	1
196	20	450	439BD196L0450	3336600158948	1	RESEGM439D196	1
200	22	450	439BD200L0450	3336600158955	1	RESEGM439D200	1
250	26	450	439BD250L0450	3336600192607	1		

Forsheda seal compatible®

ON REQUEST

- Connection 3 holes réf. 436c
- Other length
- Specifics materials

After-sales service

Segment Reloading

Your Diamond core bit is worn, our after-sales service ensures resegmentation. To obtain a quote or a support form, contact our after-sales service directly.

Tél. : +33 (0)3 84 73 74 75 - Fax : +33 (0)3 84 73 74 74

Return address :

SAV Couronne - Bâtiment N°4 - Rue Roger Thirode - 39800 Poligny

Motor and Drilling stand

For engine failures and broken parts, our after sales services carries out repairs and supplies spare parts. To obtain a quote or a support form, contact our after-sales services directly.

Tél : +33 (0)3.84.73.69.22 - Fax : +33 (0)3.84.73.74.74

Form on :

www.diager.com/fr-formulaire1.html

THE DRILLING STAND STOWS WITHOUT BENDING

FULL EQUIPMENT FRAME + ENGINE + ACCESSORIES

Composition	Ref.	Gencod	Qt.
DIAMOND EQUIPMENT 1800W (Frame+Engine+Tool set)	349E	3336600173132	1
DIAMOND EQUIPMENT 2000W (Frame+Engine+Tool set)	356E	3336600173149	1

- The frame is mounted and can be stored without having to fold it.
- The box is fitted with wheels and handles for easy transportation.



CONCRETE DIAMOND EQUIPMENT

Ref.
349H



1800W Combi 1/2"Female et 1-1/4"Male

- Power 1800W.
- Electronic overload indication.
- Ø Max. drill Concrete 120 mm and Max. drill Brick 180 mm.
- Drill connection 1/2" Female and 1-1/4" Male.
- Weight 6,3Kg.
- 2 speeds : 1000 - 2600 RPM.
- Soft grip for less vibration & anti skid.
- Quick connect motor mounting with mountig collar Ø60.

Ref.	Gencod	Qt.
349H	3336600155152	1

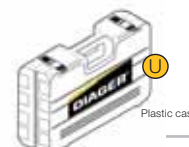

350H



2000W Combi 1/2"Female et 1-1/4"Male

- Power 2000W
- Electronic overload indication.
- Ø Max. drill Concrete 150 mm and Max. drill Brick 200 mm.
- Drill connection 1/2" Female and 1-1/4" Male.
- Weight 6,5Kg.
- 3 speeds : 450 - 1050 - 2000 RPM.
- Soft grip for less vibration & anti skid.
- Quick connect motor mounting with mountig collar Ø60.

Ref.	Gencod	Qt.
350H	3336600155169	1



398H

HAND DRILLING



2000W Combi 1/2"Female et 1-1/4"Male

- Power 2000W.
- SmarT-Tronic (soft start).
- Electrical protection system.
- For drilling in concrete up to 150 mm and brick up to 200 mm.
- Drill connection 1/2" Female and 1-1/4" Male.
- Water hose with flow indicator.
- Water or dust connection.
- Overload indicator LED.
- Double spirit level.
- Weight 7,5Kg.
- 3 speeds : 450 - 1050 - 2000 tr/min.
- Soft grip for less vibration & anti skid.
- Total length : 468mm.

Ref.	Gencod	Qt.
398H	3336600190085	1



351H



2500W 1-1/4"Male

- Power 2500W.
- Electronic overload indication.
- Motor mounting with wide housing.
- Ø Max. drill Concrete 250 mm.
- Drill connection 1-1/4" male.
- Weight 11,5Kg.
- 3 speeds : 200 - 400 - 950 tr/min.
- Waterflow indicator.

Ref.	Gencod	Qt.
351H	3336600155176	1

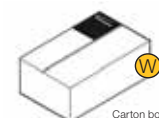

352H



3300W 1-1/4"Male

- Power 3300W.
- Electronic overload indication.
- Motor mounting with wide housing.
- Soft grip for less vibration & anti skid.
- For drilling in concrete up to 350 mm.
- Drill connection 1-1/4" male.
- Weight 12,5Kg.
- 3 speeds : 230 - 510 - 730 tr/min.
- Waterflow indicator.

Ref.	Gencod	Qt.
352H	3336600155183	1

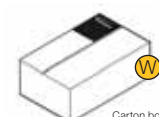

Drilling stand



- For drill motor 1800W & 2000W.
- Max Ø of the drilling: 120 mm.
- Max working length: 560 mm.
- Dimensions 26 x 20 x 90 cm.
- Weight 7 kg.

Ref.	Gencod	Qt.
348HD120	3336600155190	1



- For drill motor 1800W & 2000W.
- Max Ø of the drilling: 150 mm.
- Max working length: 560 mm.
- Dimensions 45 x 23 x 90 cm.
- Weight 8 kg.

Ref.	Gencod	Qt.
353HD150	3336600155206	1



- For drill motor 2500W & 3300W.
- Max Ø of the drilling: 250 mm.
- Max working length: 700 mm.
- Dimensions 46 x 27 x 120 cm.
- Weight 15 kg.

Ref.	Gencod	Qt.
354HD250	3336600155213	1



- For drill motor 2500W & 3300W.
- Max Ø of the drilling: 350 mm.
- Max working length: 600 mm.
- Dimensions 46 x 27 x 120 cm.
- Weight 22Kg.

Ref.	Gencod	Qt.
355HD350	3336600155220	1

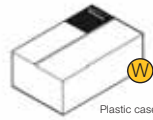

Diamond core bit accessories

Fixing by bolting

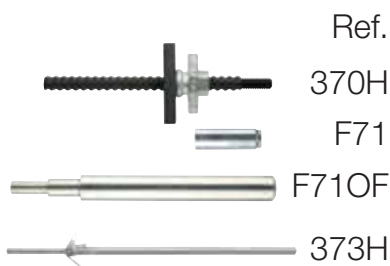

Ref.
370H
F71
F71OF
373H

Designation	Ref.	Gencod	Qt.	Pack
M12 Tensioning spindle	370H	3336600156845	1	V
Box of 50 drop-in-anchor M12x50	F71M12050000XX	3336600161641	1	S
Setting tool for M12 drop in anchor	F71M12000000F	3336600161689	1	D
Anchoing with a prop (max.300mm)	373H	3336600156876	1	W



Quality plastic pouch
European hole

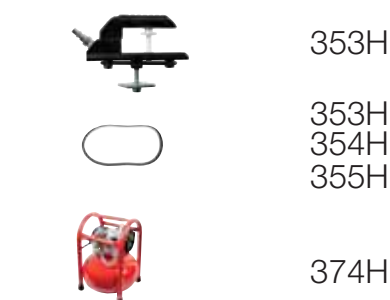

353H
353H
354H
355H
374H

Anchoring by suction

Designation	Ref.	Gencod	Qt.	Pack
Vacuum set for drilling stand D150-250-350	353HD13	3336600155299	1	V
Rubber joint for drilling stand D150	353HD14	3336600155329	1	V
Rubber joint for drilling stand D250	354HD24	3336600155336	1	V
Rubber joint for drilling stand D350	355HD34	3336600155343	1	V
Electric water pump	374H	3336600167049	1	W



Basic plastic pouch
Round metal eyelet



375H
368H

Water supply

Designation	Ref.	Gencod	Qt.	Pack
Electric water pump (pipe + 2 connections)	375H	3336600167018	1	W
Electric plastic water pump (pipe + connections)	368H	3336600156913	1	W



Twistpack
European hole



353H
354H
355H
353H
354H
355H

Water recovery

Designation	Ref.	Gencod	Qt.	Pack
Water collector for drilling stand D150, with rubber joint	353HD11	3336600155237	1	W
Water collector for drilling stand D250, with rubber joint	354HD21	3336600155244	1	W
Water collector for drilling stand D350, with rubber joint	355HD31	3336600155251	1	W
Rubber joint for water collector 353HD11	353HD12	3336600155268	1	W
Rubber joint for water collector 354HD21	354HD22	3336600155275	1	W
Rubber joint for water collector 355HD31	355HD32	3336600155282	1	W



Twistpack
Round eyelet

Adapters for drilling motors



369H
381H
382H
385H
390H
394H

Designation	Ref.	Gencod	Qt.	Pack
1-1/4" male 1/2" male	369H	3336600156944	1	M
1/2" female 1-1/4" male	381H	3336600156982	1	M
1/2" female 1-1/4" male	382H	3336600156968	1	M
1/2" female 1-1/4" male	385H	3336600156975	1	M
1/2" female 1-1/4" male	390H	3336600156951	1	M
1/2" female 1/2" female	394H	3336600178670	1	N



Carton box

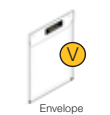

Envelope

Adapters & extensions

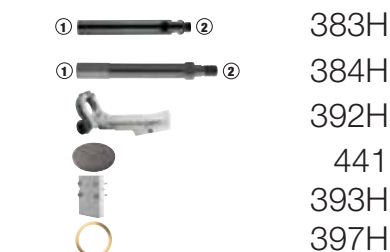

383H
384H
392H
441
393H
397H

Designation	Ref.	Gencod	Qt.	Pack
1/2" F Extension 200mm for core bit 1/2" M	383H	3336600156999	1	M
1-1/4" F Extension 300mm for core bit 1-1/4" M	384H	3336600157002	1	M
Motoradapter block - Internal 60mm for motor 1800W / 2000W on drilling stand D250 / D350	392H	3336600157019	1	W
Sharpening stone Ø 250x15 mm	441	3336600158757	1	F
Spacer block for frame 354H/355H	393H	3336600173811	1	V
Quick release ring 1-1/4" to facilitate disassembly	397H	3336600156920	1	V



Carton box

DIAMOND CONCEPT

Concept on wheels
Dimensions : H 1400 x L 1000x P 500 mm

Diamond Core bit showing

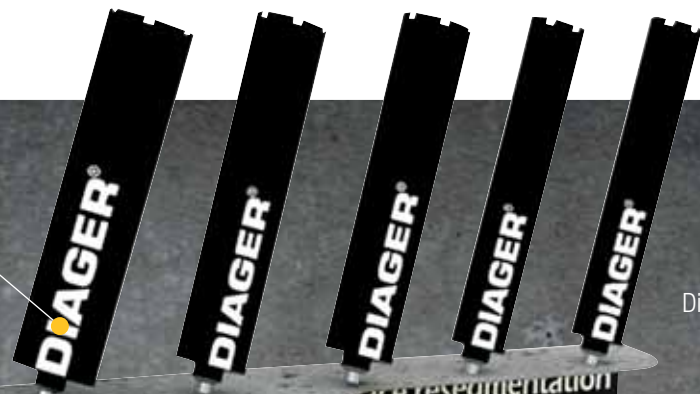

Storage area
Accessories and Adapters



ILV Informations



Space dedicated for refilling demand



Storage area
Machines



cartons de retour

Storage area

Storage area
Diamond core bit



Designation	Ref.	Gencod
Concept furniture DIAMOND	M00160	3336609005991

SANDSTONE DIAMOND CORE BIT

Ref.

426
416



Glaze, Sandstone, Glazed Sandstone, Sandware
Terracota, Marble, Tiles up to 5th class



Features

- Head with diamond segments.
- Core extraction.
- Hex shank.



Plastic box
European hole

Ø	Lu	Lt	Ref.	Gencod	Qt.
Blue Céram					
6	22	55	426D06	3336600144415	1
6,5	22	55	426D06.5	3336600157873	1
7	22	55	426D07	3336600144422	1
8	20	55	426D08	3336600144439	1
10	30	65	426D10	3336600144446	1
12	28	65	426D12	3336600144453	1
13	28	65	426D13	3336600157880	1
15	40	70	426D15	3336600144460	1
20	40	70	426D20	3336600144477	1
25	40	70	426D25	3336600144484	1

ALL
SETS
PAGES 64-64



426C



Blister
European hole

PVC Blister
European hole

Ep.	Lt	Larg.	Ref.	Gencod	Qt.	Pack
Sharpening stone						
20	160	40	416	3336600146921	1	P
18	70	35	416A	3336600186156	1	Q
20	60	40	417	3336600147331	1	film



426B

Application

with GRINDER



dry use

with DRILLER



can be used with a little water
for a more effective drilling

see our
video on
YouTube



Special mandrel grinder 124K,
Shank M14 for angle grinder,
page 36



Sharpening stone 416, 416A, 417



**STONEWARE DRILLING OF 4 AND 5 CLASS
HOLES CLEAN AND WITHOUT ANY SPLINTERS**

ROBUST
VERSATILE
CLEAN HOLES

Diamond core bit

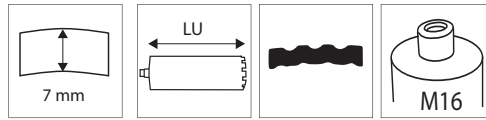

Features

- Worry segments.
- High quality diamonds.
- Ejection slot.
- M16 shank.

Benefits

- Dry use.
- No vibration.
- Use on drilling machine (recommended speed 2500 rpm).

	Ø	N.S.	Lu	Ref.	Gencod	Qt.	Pack
	Lt 88						
	68	5	66	431D68	3336600145832	1	A
	82	6	66	431D82	3336600145849	1	A
	Lt 181						
	29	3	154	432D29	3336600145856	1	N
	35	3	154	432D35	3336600145863	1	M
	42	4	154	432D42	3336600145870	1	M
	52	4	154	432D52	3336600145887	1	M
	65	5	154	432D65	3336600145894	1	M



Implementation



1/ Pre-drill with Ø8 on the desired depth.
2/ Fit the bit on the adapter and insert the centering guide.



3/ Place the centering guide with the bit in the pre-hole in order to begin coring.



4/ Drill to the desired depth.

Ref.
431
432

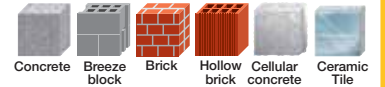

see our
video on
YouTube

Accessories

ALL SETS
PAGES 64-65

x4



431C

	Lt	Ref.	Gencod	Qt.	Pack
Compatible SDS-plus core bit adapter					
	100	367L0100	3336600063891	1	A
	170	367L0170	3336600063907	1	A
	220	367L0220	3336600063914	1	A
	320	367L0320	3336600063921	1	A
Compatible SDS-plus & SPIT core bit adapter					
	100	368L100	3336600063938	1	A
HEXA core bit adapter					
	100	433L0100	3336600145900	1	M
	220	433L0220	3336600146112	1	M
	320	433L0320	3336600146129	1	M
Ø	Lt	Ref.	Gencod	Qt.	
Centering Guide					
8	120	420D08L0120	3336600173699	1	
8	210	420D08L0210	3336600173705	1	
H	Lt	Larg.	Ref.	Gencod	Qt.
Sharpening stone for diamond core bit					
20	200	100	427	3336600155084	1

367
368
433



HEX

M16

420

Drilling Ø 8 / Guide Ø 7

427



CONCRETE CARBIDE CORE BIT

Carbide Core Bit
Compatible SDS-plus
and driller

Pro Carbide Core
Bit Compatible with
SDS-plus

Carbide Core Bit
Compatible
with SDS-max

adapter + Taper centering drill
refs. 328 ou 327 ou 365

Core bit adapter
refs. 367 ou 368

Core bit adapter
refs. 330 ou 301

Extraction kit
ref. 303

Core bit
ref. 326

Core bit
ref. 366

Taper centering drill bit
ref. 370

Taper centering drill bit
ref. 302

Core bit
ref. 300

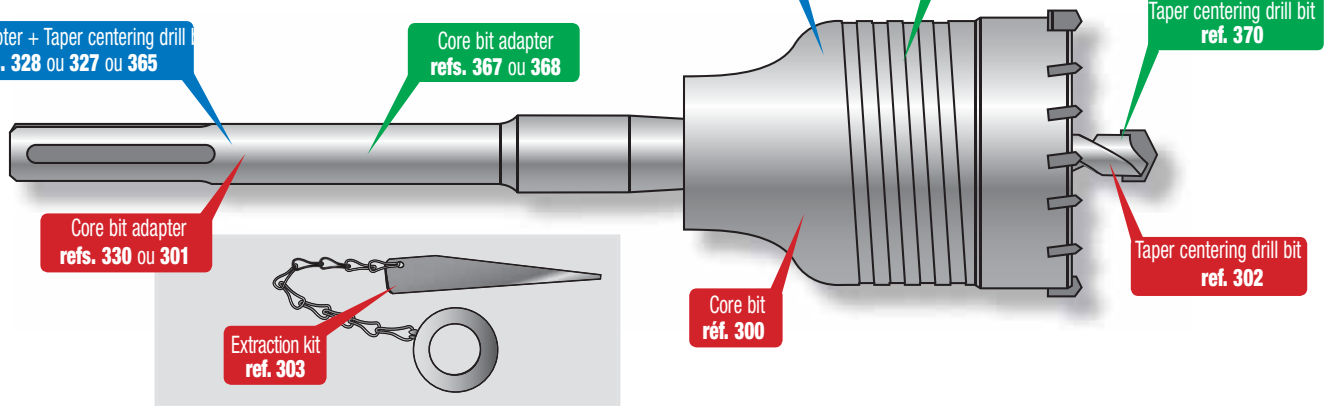

For SDS-plus hammer and driller

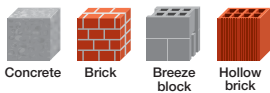

Features

- Carbide teeth welded at high temperature.
- Threaded steel.
- ALG cone-shaped shank.

Applications

- Drill big diameters for electrical installations.
- For light hammer action drills below 700W.



326C



Twistpack
European hole

Ø	Lu	Lt	Ref.	Gencod	Qt.
Core bit					
25	40	60	326D25	3336600015937	1
30	40	60	326D30	3336600015944	1
35	40	60	326D35	3336600015951	1
40	40	60	326D40	3336600015968	1
45	40	60	326D45	3336600015975	1
50	40	60	326D50	3336600015982	1
60	40	60	326D60	3336600015999	1
66	40	60	326D66	3336600016002	1
68	40	60	326D68	3336600024250	1
70	40	60	326D70	3336600016019	1
80	40	60	326D80	3336600016026	1
90	40	60	326D90	3336600016033	1



CARBIDE TEETH

Lt	Ref.	Gencod	Qt.	Pack
SDS-plus compatible core bit adapter				
90	328L0090	3336600063730	1	A
150	328L150	3336600016057	1	A
200	328L200	3336600016064	1	A
300	328L300	3336600016071	1	A
SDS-plus compatible core bit adapter				
90	327	3336600016040	1	A
HEXA core bit adapter				
135	365L0135	3336600063747	1	M



Plastic clip
European hole



Twistpack
European hole



Pro compatible SDS-plus

CARBIDE TEETH

Features

- Carbide teeth welded at high temperature.
- Threaded steel.
- M16 shank.

Applications

- Drill big diameters for electrical installations.
- For hammer drill intermediate power for 700W to 950W.



Twistpack European hole



DIY tube European hole

Ø	Lu	Lt	Ref.	Gencod	Qt.	Pack
Core bit						
30	50	70	366D30	3336600063754	1	M
35	50	70	366D35	3336600063761	1	M
40	50	70	366D40	3336600063778	1	M
45	50	70	366D45	3336600063785	1	M
50	50	70	366D50	3336600063792	1	M
60	50	70	366D60	3336600063808	1	M
66	50	70	366D66	3336600063815	1	M
68	50	70	366D68	3336600063822	1	M
70	50	70	366D70	3336600063839	1	M
80	50	70	366D80	3336600063846	1	M
85	50	70	366D85	3336600063853	1	M
90	50	70	366D90	3336600063860	1	M
105	50	70	366D105	3336600063877	1	M
125	50	70	366D125	3336600063884	1	M
130	50	70	366D130	3336600157637	1	M

Centering drill bit

Ø	Lu	Lt	Ref.	Gencod	Qt.	Pack
8	65	100	370D09L0100	3336600063952	1	H



Plastic clip European hole

Lt	Ref.	Gencod	Qt.
SDS-plus compatible core bit adapter			
100	367L0100	3336600063891	1
170	367L0170	3336600063907	1
220	367L0220	3336600063914	1
320	367L0320	3336600063921	1

SDS-plus & SPIT compatible core bit adapter

Lt	Ref.	Gencod	Qt.
100	368L100	3336600063938	1

Ref.

366
367
368
370



< 5 KG

Compatible SDS-max

CARBIDE TEETH

Features

- Strengthness and efficiency for sanitary heavy work and renovation.
- For all type of drill hammers with power of more than 950W.
- Cone-shaped shank.

Advices

- While using powerful percussion hammer drills, one needs to:
- avoid empty hammering (when only the centring bit is in the material, and not yet the core bit); that makes it necessary to pre-drill with the centring bit alone.
 - when the core bit is assembled; lock it on the taper of the core bit adapter.
 - always start drilling with the core bit using the centring bit positioned in the pre-drilled hole.
 - remove the centring bit as soon as it is no longer necessary (i.e. as soon as the core bit comes into play).



Twistpack European hole

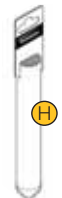

DIY tube European hole

Ø	Lu	Lt	Ref.	Gencod	Qt.	Pack
Core bit						
30	75	100	300D30	3336600016088	1	M
35	75	100	300D35	3336600016095	1	M
40	75	100	300D40	3336600012745	1	M
45	75	100	300D45	3336600016101	1	M
50	75	100	300D50	3336600016118	1	M
60	75	100	300D60	3336600012752	1	M
66	75	100	300D66	3336600012769	1	M
68	75	100	300D68	3336600187122	1	M
70	75	100	300D70	3336600016125	1	M
80	75	100	300D80	3336600016132	1	M
90	75	100	300D90	3336600016149	1	M
100	75	100	300D100	3336600012776	1	M
110	75	100	300D110	3336600016156	1	M
125	75	100	300D125	3336600016163	1	M
150	75	100	300D150	3336600186118	1	M

Centering drill bit

Ø	Lu	Lt	Ref.	Gencod	Qt.	Pack
11	90	120	302	3336600012806	1	H



Plastic clip European hole

Lt	Ref.	Gencod	Qt.	Pack
SDS-max compatible core bit adapter				
220	330L0220	3336600016194	1	A
420	330L0420	3336600012790	1	A
700	330L0700	3336600016200	1	A
900	330L0900	3336600063969	1	A



Blister European hole

Ref.	Gencod	Qt.
Extraction kit		
303	3336600012813	1

300
330
302
303

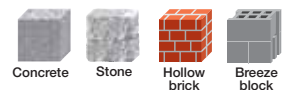

> 5 KG



CONCRETE DRILL BIT

Ref.
263

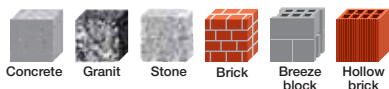

Ø Max 12.7

see our video on
YouTube

OPTIMA 3+

3 cutting edges concrete drill bit

SELF CENTERING TIP

PERFECT CONCENTRIC HOLE

Features

- Monobloc carbide tip with 3 cutting edges.
- Centering tip 130°.
- 3 flutes.
- Sandblast finishing.
- Straight shank.

Benefits

- **DURABILITY** : Improved life time due to a better pressure repartition on the 3 contact points.
- **PRECISION** : A new innovative 3 edges carbide tip, for a perfect clean and concentric hole.
- **PERFORMANCES** : Faster and safer due to its improved penetration capacity, which optimizes all fixing types.

Backside of a hole in hollow brick

Standard concrete drill bit

- Exit of hole damaged
- Thinner wall

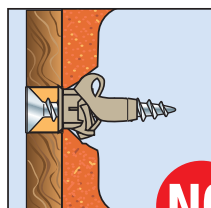

NO

OPTIMA 3+ 3 cuttings

- Perfect net hole
- Optimal fixing

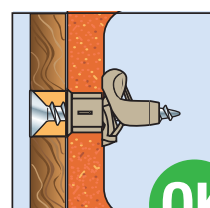

OK

ALL SETS
PAGES 62-63



Quality plastic pouch
European hole

or



DIY tube
European hole

Ø	Lu	Lt	Ref.	Gencod	Qt.
Short series					
NEW 3	20	60	263D03	3336600189638	1
4	35	75	263D04	3336600160170	1
5	45	100	263D05	3336600152991	1
6	60	100	263D06	3336600153004	1
6,5	60	100	263D06.5	3336600153998	1
8	80	120	263D08	3336600153011	1
10	80	120	263D10	3336600153028	1
12	110	150	263D12	3336600153035	1
13	110	150	263D13	3336600154001	1
L150					
5	110	150	263D05L0150	3336600076365	1
6	110	150	263D06L0150	3336600074958	1
L200					
8	160	200	263D08L0200	3336600166639	1
10	160	200	263D10L0200	3336600166646	1
12	160	200	263D12L0200	3336600166653	1
13	160	200	263D13L0200	3336600166707	1
L400					
6	360	400	263D06L0400	3336600166660	1
6,5	360	400	263D06.5L0400	3336600166714	1
8	360	400	263D08L0400	3336600166677	1
10	360	400	263D10L0400	3336600166684	1
12	360	400	263D12L0400	3336600166691	1
13	360	400	263D13L0400	3336600166721	1

* 2 cutting edges

INTENSIVE USE

MEGA

Features

- Carbide tip with semi-positive shaped.
- "U" shaped flute.
- Polished finish.
- Straight shank.

Benefits

- Polish finish with striking appeal permits dust removal.



Sleeve pack European hole

or



DIY tube European hole

ALL SETS
PAGES 62-63



Ø	Lu	Lt	Ref.	Gencod	Qt.
Short series					
3	20	60	226D03	3336600028296	1
4	35	75	226D04	3336600028302	1
5	45	85	226D05	3336600028319	1
5,5	45	85	226D05.5	3336600028470	1
6	60	100	226D06	3336600028326	1
6,5	60	100	226D06.5	3336600028487	1
7	60	100	226D07	3336600028333	1
8	80	120	226D08	3336600028340	1
9	80	120	226D09	3336600028357	1
10	80	120	226D10	3336600028364	1
11	110	150	226D11	3336600028371	1
12	110	150	226D12	3336600028388	1
13	110	150	226D13	3336600028395	1
14	110	150	226D14	3336600028401	1
15	110	150	226D15	3336600028418	1
16	110	150	226D16	3336600028425	1
18	120	160	226D18	3336600028432	1
20	120	160	226D20	3336600028449	1
22	120	160	226D22	3336600056749	1

L150					
5	110	150	226D05L0150	3336600049062	1
5,5	110	150	226D05.5L0150	3336600062719	1
6	110	150	226D06L0150	3336600049079	1
8	110	150	226D08L0150	3336600049093	1
10	110	150	226D10L0150	3336600049116	1

L200					
6	160	200	226D06L0200	3336600062740	1
8	160	200	226D08L0200	3336600049123	1
10	160	200	226D10L0200	3336600049130	1
12	160	200	226D12L0200	3336600049147	1
14	160	200	226D14L0200	3336600049154	1
16	160	200	226D16L0200	3336600049161	1

L400					
6	360	400	226D06L0400	3336600049178	1
8	360	400	226D08L0400	3336600049192	1
10	360	400	226D10L0400	3336600049215	1
12	360	400	226D12L0400	3336600049239	1
14	360	400	226D14L0400	3336600049253	1
16	360	400	226D16L0400	3336600049277	1
18	360	400	226D18L0400	3336600049284	1
20	360	400	226D20L0400	3336600049291	1

Ref.
226



Ø Max 12.7

FAST

Features

- Carbide tip with semi-positive sharpened.
- Double-rolled thread flute with land.
- Polished finish.
- Straight shank.

Benefits

- The head design permits faster drilling.



Quality plastic pouch European hole

or



Plastic pouch Round metal eyelet



208D



201C

299B

Ø	Lu	Lt	Ref.	Gencod	Qt.
Short series					
3	20	60	264D03	3336600056060	1
3,5	35	75	264D03.5	3336600056077	1
4	45	85	264D04	3336600056084	1
4,5	45	85	264D04.5	3336600056091	1
5	55	95	264D05	3336600056107	1
5,5	60	100	264D05.5	3336600056114	1
6	60	100	264D06	3336600056121	1
6,5	80	100	264D06.5	3336600056138	1
7	80	100	264D07	3336600056145	1
8	80	120	264D08	3336600056152	1
9	80	120	264D09	3336600056169	1
10	80	120	264D10	3336600056176	1
11	110	150	264D11	3336600056183	1
12	110	150	264D12	3336600056190	1
13	110	150	264D13	3336600056206	1
14	110	150	264D14	3336600056213	1
16	110	150	264D16	3336600056237	1
18	120	160	264D18	3336600056244	1
20	120	160	264D20	3336600056251	1

L150					
5	110	150	264D05L0150	3336600056268	1
6	110	150	264D06L0150	3336600056275	1
7	110	150	264D07L0150	3336600056282	1
8	110	150	264D08L0150	3336600056299	1
10	110	150	264D10L0150	3336600056312	1

L200					
6	160	200	264D06L0200	3336600056329	1
8	160	200	264D08L0200	3336600056343	1
10	160	200	264D10L0200	3336600056350	1
12	160	200	264D12L0200	3336600056367	1
14	160	200	264D14L0200	3336600056374	1

ALL SETS
PAGES 62-63

Pro

264

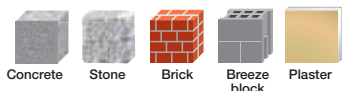

Ø Max 12.7

CONCRETE DRILL BIT

Ref.

265

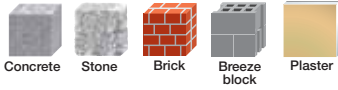

Ø Max 12.7

FLASH

FOR CORDLESS DRILLS

Features

- Multi-angles carbide tighter grade.
- Sandblasted finish.
- Straight shank.

Benefits

- Carbide grade for longer life.
- Higher tip for better guiding.

MORE THAN 20%
BATTERY LIFE TIME



ALL SETS
PAGES 62-63



Ø	Lu	Lt	Ref.	Gencod	Qt.
Short series					
3	20	60	265D03	3336600064485	1
3,5	35	75	265D03.5	3336600064492	1
4	35	75	265D04	3336600064508	1
4,5	45	85	265D04.5	3336600064515	1
5	45	85	265D05	3336600064522	1
5,5	55	95	265D05.5	3336600064539	1
6	60	100	265D06	3336600064546	1
6,5	60	100	265D06.5	3336600064553	1
7	60	100	265D07	3336600064560	1
7,5	80	120	265D07.5	3336600064577	1
8	80	120	265D08	3336600064584	1
8,5	80	120	265D08.5	3336600064591	1
9	80	120	265D09	3336600064607	1
9,5	80	120	265D09.5	3336600064614	1
10	80	120	265D10	3336600064621	1
11	110	150	265D11	3336600064638	1
12	110	150	265D12	3336600064645	1
13	110	150	265D13	3336600064652	1
14	110	150	265D14	3336600064669	1
15	110	150	265D15	3336600064676	1
16	110	150	265D16	3336600064683	1
17	110	150	265D17	3336600064690	1
18	120	160	265D18	3336600064706	1
19	120	160	265D19	3336600064713	1
20	120	160	265D20	3336600064720	1
22	120	160	265D22	3336600064737	1
25	120	160	265D25	3336600064744	1
L150					
5	110	150	265D05L0150	3336600076365	1
5,5	110	150	265D05.5L0150	3336600052666	1
6	110	150	265D06L0150	3336600074958	1
6,5	110	150	265D06.5L0150	3336600052673	1
7	110	150	265D07L0150	3336600074996	1
8	110	150	265D08L0150	3336600075023	1
9	110	150	265D09L0150	3336600084056	1
10	110	150	265D10L0150	3336600075078	1
L200					
6	160	200	265D06L0200	3336600074965	1
7	160	200	265D07L0200	3336600075009	1
8	160	200	265D08L0200	3336600075030	1
10	160	200	265D10L0200	3336600075085	1
12	160	200	265D12L0200	3336600075122	1
14	160	200	265D14L0200	3336600075184	1
16	160	200	265D16L0200	3336600081284	1

Ø	Lu	Lt	Ref.	Gencod	Qt.
L300					
6	260	300	265D06L0300	3336600074972	1
6,5	260	300	265D06.5L0300	3336600088184	1
7	260	300	265D07L0300	3336600075016	1
8	260	300	265D08L0300	3336600075047	1
9	260	300	265D09L0300	3336600075188	1
10	260	300	265D10L0300	3336600075092	1
12	260	300	265D12L0300	3336600075139	1
13	260	300	265D13L0300	3336600075160	1
14	260	300	265D14L0300	3336600075191	1
15	260	300	265D15L0300	3336600077171	1
16	260	300	265D16L0300	3336600075221	1
18	260	300	265D18L0300	3336600075245	1
20	260	300	265D20L0300	3336600075269	1
L400					
6	360	400	265D06L0400	3336600074989	1
7	360	400	265D07L0400	3336600084063	1
8	360	400	265D08L0400	3336600075054	1
9	360	400	265D09L0400	3336600075061	1
10	360	400	265D10L0400	3336600075108	1
12	360	400	265D12L0400	3336600075146	1
14	360	400	265D14L0400	3336600075207	1
15	360	400	265D15L0400	3336600082533	1
16	360	400	265D16L0400	3336600075238	1
18	360	400	265D18L0400	3336600075252	1
20	360	400	265D20L0400	3336600075276	1
22	360	400	265D22L0400	3336600075290	1
24	360	400	265D24L0400	3336600084094	1
25	360	400	265D25L0400	3336600075313	1
L600					
6	560	600	265D06L0600	3336600077874	1
8	560	600	265D08L0600	3336600077867	1
10	560	600	265D10L0600	3336600075115	1
12	560	600	265D12L0600	3336600075153	1
14	560	600	265D14L0600	3336600075214	1
16	560	600	265D16L0600	3336600076303	1
18	560	600	265D18L0600	3336600076310	1
20	560	600	265D20L0600	3336600076327	1
22	560	600	265D22L0600	3336600077157	1
L1000					
6	960	1000	265D06L1000	3336600101593	1
8	960	1000	265D08L1000	3336600101609	1
10	960	1000	265D10L1000	3336600101616	1
12	960	1000	265D12L1000	3336600101623	1
15	960	1000	265D15L1000	3336600101647	1
16	960	1000	265D16L1000	3336600101654	1
18	960	1000	265D18L1000	3336600101661	1
20	960	1000	265D20L1000	3336600101678	1
22	960	1000	265D22L1000	3336600101685	1
25	960	1000	265D25L1000	3336600101692	1
L1200					
8	1160	1200	265D08L1200	33366000101708	1
10	1160	1200	265D10L1200	33366000101715	1

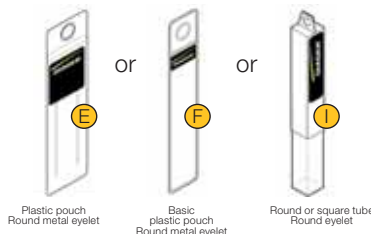

Multimaterials

Ref.
215

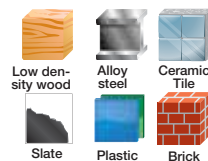

Features

- Positive sharpening with centering point.
- Angle 118°.
- 4 sharpened edges.
- L shaped flute.
- Straight shank.

Benefits

- Universal use.
- Perfect clean hole.
- Fast penetration.



Ø Max 12.7

ALL SETS
PAGES 64-65



215C



215B



Quality plastic pouch
European hole

or

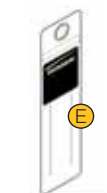

Plastic pouch
Round metal eyelet

Ø	Lu	Lt	Ref.	Gencod	Qt.
3	20	60	215D03	3336600153813	1
4	35	75	215D04	3336600153820	1
5	45	85	215D05	3336600153837	1
5,5	45	85	215D05.5	3336600153844	1
6	60	100	215D06	3336600153851	1
6,5	60	100	215D06.5	3336600153868	1
7	60	100	215D07	3336600153875	1
8	80	120	215D08	3336600153882	1
9	80	120	215D09	3336600153899	1
10	80	120	215D10	3336600153905	1
12	110	150	215D12	3336600153912	1
13	110	150	215D13	3336600153929	1
14	110	150	215D14	3336600153936	1
16	110	150	215D16	3336600153950	1
L250					
6	210	250	215D06L0250	3336600173286	1
6,5	210	250	215D06.5L0250	3336600173293	1
8	210	250	215D08L0250	3336600173309	1
L300					
10	260	300	215D10L0300	3336600173415	1
12	260	300	215D12L0300	3336600173422	1
13	260	300	215D13L0300	3336600173439	1





Ref.
245



Ø Max 12.7

Ceramik drill bit

Features

- Heavy duty carbide tip.
- Positive sharpening edges and centering point.
- L shaped flute.
- Blue finish.
- Straight shank.



Ø	Lu	Lt	Ref.	Gencod	Qt.
3	20	60	245D03	3336600022058	1
4	35	75	245D04	3336600022065	1
5	45	85	245D05	3336600022072	1
6	60	100	245D06	3336600022089	1
7	60	100	245D07	3336600022720	1
8	80	120	245D08	3336600022096	1
9	80	120	245D09	3336600022737	1
10	80	120	245D10	3336600022102	1
12	110	150	245D12	3336600022744	1



Sleeve pack
European hole



208



Ø Max 12.7

Hard stone & granit drill bit

Features

- Heavy duty carbide tip.
- Positive sharpening.
- L shaped flute.
- Straight shank.



Ø	Lu	Lt	Ref.	Gencod	Qt.
3	20	60	208D03	3336600157545	1
4	35	85	208D04	3336600022355	1
5	45	100	208D05	3336600022362	1
5,5	35	85	208D05,5	3336600022379	1
6	60	100	208D06	3336600022386	1
6,5	60	100	208D06,5	3336600022393	1
7	60	100	208D07	3336600022409	1
8	80	120	208D08	3336600022416	1
9	80	120	208D09	3336600022423	1
10	80	120	208D10	3336600022430	1
12	110	150	208D12	3336600022454	1
14	110	150	208D14	3336600022461	1
16	110	150	208D16	3336600022485	1



Sleeve pack
European hole



403



Scribing iron

Features

- Scribing iron, with hex-shank 6 or 8 mm.

Applications

- For an accurate tracing on sheet-metal plate.



Quality plastic pouch
European hole

Ø	Ref.	Gencod	Qt.
6	403	3336600016477	1



407



Carbide claw

Features

- The tool is fitted with a cutting point the carbide.
- Wooden handle.

Applications

- Using a rule, just scratch the surface of the material and then the break in this place.
- Simple but effective for cut sheet of zinc, of laminate, slate.



Plastic pouch
Round eyelet

Ref.	Gencod	Qt.
407	3336600002326	1

Glass & tile drill bit

Ref.
400

Features

- New harder carbide grade - Made in Europe.
- 4 sided design "diamond style" with aggressive cutting edges (special Diager sharpening).
- Fast spiral with tightened pitch.
- Total length improved.

Benefits

- Aggressive tip improves precision and penetration.
- Drilling through up to class 3 ceramic tiles
- Use dry for easy work.
- Better resistance to high temperature when drilling.
- Speed up dust extraction.
- Ideal for deep materials.
- Suitable for more materials: non-tempered glass, plastic, composite, brick, marble.
- Identifying design.

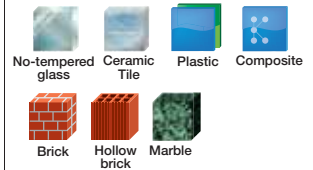

Ø Max 12.7

LENGTH

- Total length improved
- Shiny / copper finishing

Benefits

- Allows drilling into deep materials
- Suitable for more applications
- New Diager design

FAST SPIRAL

- Tightened pitch

Benefits

- Speed up dust removal
- Better in deep materials

CARBIDE TIP

- High hardness carbide tip (made in Europe)
- New 4 faces carbide tip design
- Copper brazing

Benefits

- Accurate drilling precision
- Better penetration results
- Drilling through tiles up to class 3
- Dry and wet applications
- Better resistance to friction



ALL SETS PAGES 64-65

x5



408C

Ø	Lu	Lt	Ref.	Gencod	Qt.
3	40	80	400D03	3336600014466	1
4	40	80	400D04	3336600014473	1
5	40	80	400D05	3336600014480	1
6	40	80	400D06	3336600014497	1
7	60	100	400D07	3336600014503	1
8	60	100	400D08	3336600014510	1
9	60	100	400D09	3336600014527	1
10	60	100	400D10	3336600014534	1
12	60	100	400D12	3336600014541	1
13	60	100	400D13	3336600093546	1



Quality plastic pouch European hole

Ref.
201



Special drill bit for external and internal cladding panels, furniture and decoration surfacing products

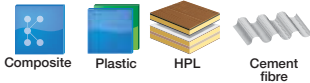

Features

- Carbide tip with 2 tracers.
- Crown sharpening.
- Centring tip cut at 75°.
- Glossy polished finish.
- Cylindrical attachment.

Benefits

- Clean hole without chips.
- Self centering point for easy starts.
- Long service life.
- Fast penetration.

Applications

- Used to drill interior fitting panels such as corian®, wood, composite materials, plastic, or cement fiber or HPL façade panels...

SPECIAL DRILL BIT FOR COMPOSITE MATERIALS
LONGER LIFE TIME

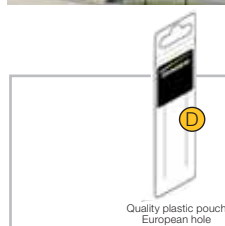

Quality plastic pouch
European hole

Ø	Lu	Lt	Ref.	Gencod	Qt.
5		85	201D05	3336600174948	1
6		100	201D06	3336600174955	1
8		120	201D08	3336600174962	1
10		120	201D10	3336600174979	1

170B



Ice



Ice drill bit

FOR ICE

Compatible SDS-plus or Hex-shank

Features

- 3 cutting edges head.
- Deep cutting flute.
- Compatible SDS-plus shank.

Applications

- Profile of head and flute designed for ice.

Ø	Lu	Lt	Ref.	Gencod	Qt.
On request					
Compatible SDS-plus					
28	405	540	170BD28L0540	3336600119307	1
30	405	540	170BD30L0540	3336600119314	1
32	405	540	170BD32L0540	3336600119321	1
35	405	540	170BD35L0540	3336600119338	1
6 pans					
28	405	540	170D28L0540	3336600167544	1
30	405	540	170D30L0540	3336600167551	1
32	405	540	170D32L0540	3336600167568	1
35	405	540	170D35L0540	3336600167575	1



Paperboard



Ref.143B



Ref.147B

Adapters, page 35

SCREWDRIVER

HSS metal drill bit

Features

- Monobloc drill bit.
- Carbide tip.
- Positive sharpening.
- L shaped flute.
- Hex-shank 1/4" - 6,35 mm.

Ref.

781

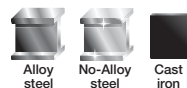

DIN 338



6.35

ALL SETS
PAGES 64-65



Plastic tube
European hole

Ø	Lu	Lt	Ref.	Gencod	Qt.
3	26	60	781D03	3336600166813	1
3,3	26	60	781D03,3	3336600166820	1
3,5	30	65	781D03,5	3336600166837	1
4	30	65	781D04	3336600166844	1
4,2	30	65	781D04,2	3336600166851	1
4,5	30	65	781D04,5	3336600166868	1
5	34	68	781D05	3336600166875	1
6	34	70	781D06	3336600166882	1
8	38	79	781D08	3336600166905	1

Wood 3 points drill bit

Features

- Monobloc drill bit.
- 3 points.
- Double flute.
- Hex-shank 1/4" - 6,35 mm.

981



6.35



Plastic tube
European hole

Ø	Lu	Lt	Ref.	Gencod	Qt.
3	35	65	981D03	3336600166936	1
4	40	75	981D04	3336600166943	1
5	50	85	981D05	3336600166950	1
6	55	90	981D06	3336600166967	1
7	55	90	981D07	3336600166929	1
8	55	90	981D08	3336600166974	1
10	60	100	981D10	3336600166981	1



CONCRETE

BOOSTER-PLUS



TWISTER-PLUS



Features	Pcs	Type	Composition	Ref.	Gencod
BOOSTER-PLUS	10	pouch	L160mm Ø6(x3)-8(x3)-10(x2)-12-14mm	072B	3336600104082
BOOSTER-PLUS	22	ABS set	L110mm Ø 5-6 L160mm Ø 6-8(x2)-10 hss drill bits Ø 3-4-5(x2)-6(x2)-8mm screw bits bits PZ1-2(x2)-3 PH2(x2) TX15-20 + Standard Bit holder	065B	3336600190115
BOOSTER-PLUS	35	ABS set	L110mm Ø 5-6 L160mm Ø 6-8(x2)-10 Torsion screw bits PZ1(x2)-2(x3)-3(x3) PH1-2(x3)-3(x2) TX10-15-20(x3)-25(x2) 30(x2)-40 Lg50mm PZ2-PH2(x2)-TX25 + FOXII Bit holder	108B	3336600183728
BOOSTER-PLUS	5	set	L110mm Ø6-8 L160mm Ø6-8-10mm	104B	3336600075658
BOOSTER-PLUS	5	set	L110mm Ø5(x2) L160mm Ø6 (x2)-8mm	115C	3336600141278
BOOSTER-PLUS	7	metal set	L110mm Ø6-8-10 L160mm Ø6-8-10-12mm	113D	3336600060876
TWISTER-PLUS	10	pouch	L110mm Ø5-6-8 L160mm Ø6(x2)-8(x2)-10-12-14mm	116D	3336600007406
TWISTER-PLUS	22	ABS set	L110mm Ø 5-6 L160mm Ø 6-8(x2)-10 HSS pro drill bit Ø 3-4-5(x2)-6(x2)-8mm Torsion screw bits PZ1-2(x2)-3 PH2(x2) TX15-20 + Standard Bit holder	062C	3336600184015
TWISTER-PLUS	35	ABS set	L110mm Ø 5-6 L160mm Ø 6-8(x2)-10 Torsion screw bits PZ1(x2)-2(x3)-3(x3) PH1-2(x3)-3(x2) TX10-15-20(x3)-25(x2) 30(x2)-40 Lg50mm PZ2-PH2(x2)-TX25 + FOXII Bit holder	118B	3336600188815
TWISTER-PLUS	4	set	L160mm Ø5-6-8-10mm	100C	3336600064881
TWISTER-PLUS	5	set	L110mm Ø6-8 L160mm Ø6-8-10mm	136C	3336600054202
TWISTER-PLUS	7	set	L110mm Ø5-6-8 L160mm Ø6-8-10-12mm	102C	3336600064904
TWISTER-PLUS	7	metal set	L110mm Ø5-6-8 L160mm Ø6-8-10-12mm	105D	3336600007369



Features	Pcs	Type	Composition	Ref.	Gencod
FLASH	5	set	Flash 04-5-6-7-8mm	252C	333660006911
FLASH	5	set	Flash 04-5-6-8-10mm	251C	333660006904
FLASH	8	set	Flash 03-4-5-6-7-8-9-10mm	250C	333660006898
OPTIMA	5	solo	Optima-3 04-5-6-8-10mm	263B	3336600160484
MEGA	5	solo	Mega 04-5-6-8-10mm	211C	3336600064973
MEGA	8	duo	Mega 03-4-5-6-7-8-9-10mm	256C	3336600083578
PRO	5	solo	Pro 04-5-6-8-10mm	201C	333660006935
PRO	8	duo	Pro 03-4-5-6-7-8-9-10mm	299B	3336600107670
PRO	7	metal set	Pro 04-5-6-7-8-10-12mm	208D	333660007444
POINTED & CHISEL SDS-PLUS	5	case	SDS-Plus Pointed 14x250(x2) Chisel 20x250(x2) 40x250mm	111C	3336600167469
POINTED & CHISEL DEMOLITION	5	case	SDS-Max Pointed 18x400(x2) Chisel 24x400(x2) 50x360mm	315C	3336600180635



SPECIFIC



207B



239B



214B



215C



215B



431C



326C

Features	Pcs	Type	Composition	Ref.	Gencod
GRANIT	8	duo	Granit Ø3-4-5-6-7-8-9-10mm	207B	333660075665
CERAMIK	8	duo	Ceramik Ø3-4-5-6-7-8-9-10mm	239B	333660075672
CERAMIK	5	solo	Ceramik Ø4-5-6-8-10mm	214B	3336600107687
MULTIMATERIALS	8	set	Multimaterials Ø3-4-5-6-7-8-9-10mm	215C	3336600166783
MULTIMATERIALS	5	solo	Multimaterials Ø4-5-6-8-10mm	215B	3336600166790
DIAMOND CORE BIT	1	kit	Diamond core bit Ø68 + core bit adapter SDS-Plus L100 + centering	431C	3336600162662
ELECTRICIAN CORE BIT	1	kit	Electrician core bit Ø 68	326C	3336600157569





x10

781B



x6

426C



x5

408C



x9

426B

Features	Pcs	Type	Composition	Ref.	Gencod
HEX HSS	10	coffret	Hexa HSS drill bit Ø3-3.3-3.5-4-4.2-4.5-5-5.5-6-8mm	781B	3336600166912
CERATILE	5	coffret	Ceratile06 (X3)-08(X2)mm	408C	3336600178601
BLUE CERAM	9	mallette	Blue-ceram 06 (x2)-8 (x2)-10-15-20mm chuck & Stone sharpening	426B	3336600160224
BLUE CERAM	6	coffret	Blue-ceram 6pcs 06(x2)-8(x2)mm chuck & Stone sharpening	426C	3336600151901



Drilling metal guide

Ref.	Designation	Attachement	Origin & Standards	Benefits	Page
731 700	5% Cobalt	Straight shank	DIN 338	<ul style="list-style-type: none"> • Stainless steel special • Resistance to overheating • Long life 	68
702 703	HSS G3	Straight shank	DIN 338	<ul style="list-style-type: none"> • Ease of evacuation • Coating anti-heating • Long life 	69
732 728	HSS Tin	Straight shank	DIN 338	<ul style="list-style-type: none"> • Titanium coating • Resistance to overheating • Speed and ease of drill hole • Ideal compromise for general use 	70
729 726	HSS Pro	Straight shank	DIN 338	<ul style="list-style-type: none"> • Speed and ease of drill hole • Ideal compromise for general use 	72-73
735 713 712 715	HSS Pro	Straight shank	DIN 340 DIN 1897	<ul style="list-style-type: none"> • Speed and ease of drill hole • Ideal compromise for general use 	71
769 750	HSS Standard	Straight shank	DIN 338	<ul style="list-style-type: none"> • Occasional use 	74
504	HSS 90° countersink	Flat	DIN 3352	<ul style="list-style-type: none"> • Chamfer and deburring • Stainless steel drilling • Long life 	77
500B 501B 502B	HSS Tin step drill bit	Straight shank		<ul style="list-style-type: none"> • Hole Ø4 to 30 • Titanium coating anti overheating 	75
511B 512B 513B	HSS Tin step drill bit	Straight shank		<ul style="list-style-type: none"> • Hole Ø4 to 38 	75
865 867	Die		DIN 352 DIN 376	<ul style="list-style-type: none"> • Manual use • Kit of 3 taps (Draft, intermediate, finisher) 	76
825 826	Tap			<ul style="list-style-type: none"> • Realization or restoration of outside threads • Manual use 	76
D2409 D2418	TCT HSS drill bit	Straight shank	DIN 338 DIN 340 	<ul style="list-style-type: none"> • Precision mechanics • Use on column drills • Drilling of steels up to 2100 Nm² 	78
781	HSS drill bit 6,35	Quick lock	DIN 338	<ul style="list-style-type: none"> • Screwdriver special 	61

Ref.

731 700

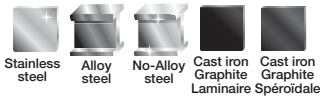

DIN 338

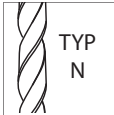
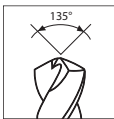

HSS-E
5 % Co

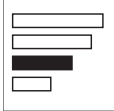

Ø Max 12.7

HSS Cobalt 5%

Features

- Fully ground drill bit 5% cobalt HSS-E.
- 135° tip angle.
- Split point.
- Flute type N.
- Diameter tolerance h8.

Benefits

- Starting precision.
- The cobalt content makes the bit harder and heightens temperature resistance, for work with hard metals such as stainless steel.

Applications

- Unalloyed and alloyed steels (up to 1200/mm²), stainless steel, cast iron.
- The basic choice for industrial applications and the drilling of materials difficult to machine.



Quality plastic pouch
European hole

Ø	Lu	Lt	Ref.	Gencod	Qt.
2	24	49	731D02	3336600021563	1
2,5	30	57	731D02.5	3336600021570	1
3	33	61	731D03	3336600021587	1
3,2	36	65	731D03.2	3336600021600	1
3,5	39	70	731D03.5	3336600021631	1
4	43	75	731D04	3336600021662	1
4,2	43	75	731D04.2	3336600021686	1
4,5	47	80	731D04.5	3336600021716	1
5	52	86	731D05	3336600021761	1
5,2	52	86	731D05.2	3336600021785	1
5,5	57	93	731D05.5	3336600021815	1
6	57	93	731D06	3336600021846	1
6,2	63	101	731D06.2	3336600021853	1
6,5	69	109	731D06.5	3336600021860	1
7	69	109	731D07	3336600021884	1
7,5	75	117	731D07.5	3336600021891	1
8	75	117	731D08	3336600021907	1
8,5	81	125	731D08.5	3336600021921	1
9	81	125	731D09	3336600021938	1
9,5	87	133	731D09.5	3336600021952	1
10	87	133	731D10	3336600021969	1
10,5	94	142	731D10.5	3336600021976	1
11	94	142	731D11	3336600021983	1
11,5	101	151	731D11.5	3336600021990	1
12	101	151	731D12	3336600022003	1
12,5	101	151	731D12.5	3336600022010	1
13	101	151	731D13	3336600022027	1

5 to 10
PIECES

Ø	Lu	Lt	Ref.	Gencod	Qt.
2	24	49	700D02	3336600016644	1=10
2,5	30	57	700D02.5	3336600016651	1=10
3	33	61	700D03	3336600016668	1=10
3,2	36	65	700D03.2	3336600016682	1=10
3,3	36	65	700D03.3	3336600016699	1=10
3,5	39	70	700D03.5	3336600016712	1=10
4	43	75	700D04	3336600016743	1=10
4,2	43	75	700D04.2	3336600016767	1=10
4,5	47	80	700D04.5	3336600016798	1=10
4,8	52	86	700D04.8	3336600016828	1=10
5	52	86	700D05	3336600016842	1=10
5,2	52	86	700D05.2	3336600016866	1=10
5,5	57	93	700D05.5	3336600016897	1=10
6	57	93	700D06	3336600016927	1=10
6,2	63	101	700D06.2	3336600016934	1=10
6,5	63	101	700D06.5	3336600016941	1=10
6,8	69	109	700D06.8	33366000167285	1=10
7	69	109	700D07	3336600016965	1=10
7,5	75	117	700D07.5	3336600016972	1=10
8	75	117	700D08	3336600016989	1=10
8,5	81	125	700D08.5	3336600016996	1=10
9	81	125	700D09	3336600017009	1=10
9,5	81	125	700D09.5	3336600017023	1=10
10	87	133	700D10	3336600017030	1=10
10,5	87	133	700D10.5	3336600017047	1=5
11	94	142	700D11	3336600017054	1=5
11,5	94	142	700D11.5	3336600017061	1=5
12	94	142	700D12	3336600017078	1=5
12,5	101	151	700D12.5	3336600017085	1=5
13	101	151	700D13	3336600017092	1=5



Quadropack
European hole

ALL SETS
PAGES 80-81

x19
708D

x25
707D

x6
706C

x10
720C

x13
721C

Multi-layers coating

Ref.

702
703

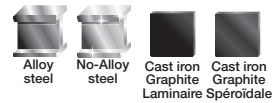

Features

- Fully ground drill HSS.
- Multi-coated slides Titanium, Aluminium, Nickel.
- 135° tip angle.
- Split point.
- Flute type S.
- Diameter tolerance h8.

Benefits

- Starting precision.
- Multiple coating that acts as a thermal barrier against heating and allows a longer life.
- The coating reduces friction, facilitates dust removal and increases the cutting speed.
- The type S flute makes it possible to remove medium and long chips.



DIN 338

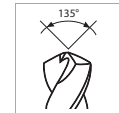

Ø Max 12.7

Ø	Lu	Lt	Ref.	Gencod	Qt.
1	12	34	702D01	3336600154773	1=2
1,5	18	40	702D01.5	3336600154780	1=2
2	24	49	702D02	3336600154797	1=2
2,5	30	57	702D02.5	3336600154803	1=2
3	36	65	702D03	3336600154810	1=2
3,2	36	65	702D03.2	3336600154827	1=2
3,3	36	65	702D03.3	3336600157828	1=2
3,5	39	70	702D03.5	3336600154834	1=2
4	43	75	702D04	3336600154841	1=2
4,2	43	75	702D04.2	3336600154858	1=2
4,5	47	80	702D04.5	3336600154865	1=2
4,8	52	86	702D04.8	3336600154872	1=2
5	52	86	702D05	3336600154889	1=2
5,2	52	86	702D05.2	3336600154896	1
5,5	57	93	702D05.5	3336600154902	1
6	57	93	702D06	3336600154919	1
6,2	63	101	702D06.2	3336600154926	1
6,5	63	101	702D06.5	3336600154933	1
6,8	69	109	702D06.8	3336600154940	1
7	69	109	702D07	3336600154957	1



Plastic tube European hole

Ø	Lu	Lt	Ref.	Gencod	Qt.
7,5	69	109	702D07.5	3336600154964	1
8	75	117	702D08	3336600154971	1
8,5	75	117	702D08.5	3336600154988	1
9	81	125	702D09	3336600154995	1
9,5	81	125	702D09.5	3336600155008	1
10	87	133	702D10	3336600155015	1
10,2	87	133	702D10.2	3336600157835	1
10,5	87	133	702D10.5	3336600155022	1
11	94	142	702D11	3336600155039	1
11,5	94	142	702D11.5	3336600155046	1
12	101	151	702D12	3336600155053	1
12,5	101	151	702D12.5	3336600155060	1
13	101	151	702D13	3336600155077	1
14	108	160	702D14	3336600164529	1
15	114	169	702D15	3336600164536	1
16	120	178	702D16	3336600164543	1
17	125	184	702D17	3336600179073	1
18	130	191	702D18	3336600179080	1
19	135	198	702D19	3336600179097	1
20	140	205	702D20	3336600179103	1

2 to 10
PIECES

Ø	Lu	Lt	Ref.	Gencod	Qt.
1	12	34	703D01	3336600157903	1=10
1,2	16	38	703D01,2	3336600177024	1=10
1,3	16	38	703D01,3	3336600177031	1=10
1,4	18	40	703D01,4	3336600177048	1=10
1,5	18	40	703D01,5	3336600157910	1=10
1,6	20	43	703D01,6	3336600177055	1=10
1,8	22	46	703D01,8	3336600177062	1=10
2	24	49	703D02	3336600157927	1=10
2,3	27	53	703D02,3	3336600177079	1=10
2,4	30	57	703D02,4	3336600177086	1=10
2,5	30	57	703D02,5	3336600157934	1=10
2,6	30	57	703D02,6	3336600177093	1=10
2,7	30	61	703D02,7	3336600177109	1=10
2,9	30	61	703D02,9	3336600177116	1=10
3	36	65	703D03	3336600157941	1=10
3,1	36	65	703D03,1	3336600177123	1=10
3,2	36	65	703D03,2	3336600157958	1=10
3,3	36	65	703D03,3	3336600157965	1=10
3,4	39	70	703D03,4	3336600177130	1=10
3,5	39	70	703D03,5	3336600157972	1=10
3,6	39	70	703D03,6	3336600177147	1=10
3,7	39	70	703D03,7	3336600177154	1=10
3,8	43	75	703D03,8	3336600177161	1=10
4	43	75	703D04	3336600157989	1=10
4,1	43	75	703D04,1	3336600177178	1=10
4,2	43	75	703D04,2	3336600157996	1=10
4,3	47	80	703D04,3	3336600177185	1=10
4,5	47	80	703D04,5	3336600158009	1=10
4,6	47	80	703D04,6	3336600177192	1=10
4,7	47	80	703D04,7	3336600177208	1=10
4,8	52	86	703D04,8	3336600158016	1=10
4,9	52	86	703D04,9	3336600177215	1=10
5	52	86	703D05	3336600158023	1=10
5,1	52	86	703D05,1	3336600177222	1=10



Quadropack Round eyelet

Ø	Lu	Lt	Ref.	Gencod	Qt.
5,2	52	86	703D05,2	3336600158030	1=10
5,3	52	86	703D05,3	3336600177239	1=10
5,5	57	93	703D05,5	3336600158047	1=10
5,8	57	93	703D05,8	3336600177246	1=10
6	57	93	703D06	3336600158054	1=10
6,1	63	101	703D06,1	3336600177253	1=10
6,2	63	101	703D06,2	3336600158061	1=10
6,5	63	101	703D06,5	3336600158078	1=10
6,7	63	101	703D06,7	3336600177260	1=10
6,8	69	109	703D06,8	3336600158085	1=10
7	69	109	703D07	3336600158092	1=10
7,3	69	109	703D07,3	3336600177277	1=10
7,4	69	109	703D07,4	3336600177284	1=10
7,5	69	109	703D07,5	3336600158108	1=10
8	75	117	703D08	3336600158115	1=10
8,2	75	117	703D08,2	3336600177291	1=10
8,5	75	117	703D08,5	3336600158122	1=10
8,7	81	125	703D08,7	3336600177307	1=10
9	81	125	703D09	3336600158139	1=10
9,5	81	125	703D09,5	3336600158146	1=10
10	87	133	703D10	3336600158153	1=10
10,2	87	133	703D10,2	3336600177314	1=5
10,5	87	133	703D10,5	3336600158160	1=5
11	94	142	703D11	3336600158177	1=5
11,5	94	142	703D11,5	3336600158184	1=5
12	101	152	703D12	3336600158191	1=5
12,5	101	152	703D12,5	3336600158207	1=5
13	101	151	703D13	3336600158214	1=5
13,5	108	160	703D13,5	3336600181106	1=2
14	108	160	703D14	3336600177321	1=2
14,5	114	169	703D14,5	3336600181113	1=2
15	114	169	703D15	3336600177338	1=2
15,5	120	178	703D15,5	3336600181120	1=2
16	120	178	703D16	3336600177345	1=2

Ref.

732
728

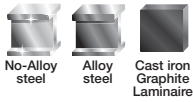

DIN 338

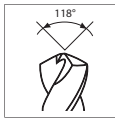

TIN



Ø Max 12.7

HSS Tin

Features

- Fully ground drill bit HSS-TIN.
- Titanium nitride coating.
- 118° tip angle.
- Split point.
- Flute type N.
- Diameter tolerance h8.

Benefits

- Starting precision.
- Quick penetration and easy drilling.
- The TIN coating makes the bit harder and extends its life.

Applications

- Unalloyed and alloyed steels (up to 1100N/mm²).



Ø	Lu	Lt	Ref.	Gencod	Qt.
1	12	34	732D01	3336600017108	1
1,5	18	40	732D01.5	3336600017115	1
2	24	49	732D02	3336600011748	1
2,5	30	57	732D02.5	3336600011755	1
3	33	61	732D03	3336600011762	1
3,2	36	65	732D03.2	3336600011779	1
3,5	39	70	732D03.5	3336600011786	1
4	43	75	732D04	3336600011793	1
4,2	43	75	732D04.2	3336600011809	1
4,5	47	80	732D04.5	3336600011816	1
5	52	86	732D05	3336600011823	1
5,2	52	86	732D05.2	3336600017252	1
5,5	57	93	732D05.5	3336600011830	1
6	57	93	732D06	3336600011847	1
6,5	63	101	732D06.5	3336600011854	1
7	69	109	732D07	3336600011861	1
7,5	69	109	732D07.5	3336600011878	1
8	75	117	732D08	3336600011885	1
8,5	75	117	732D08.5	3336600011892	1
9	81	125	732D09	3336600011908	1
9,5	81	125	732D09.5	3336600012417	1
10	87	133	732D10	3336600011915	1
10,5	87	133	732D10.5	3336600017320	1
11	94	142	732D11	3336600012424	1
11,5	94	142	732D11.5	3336600017337	1
12	101	151	732D12	3336600012431	1
12,5	101	151	732D12.5	3336600017344	1
13	101	151	732D13	3336600012448	1

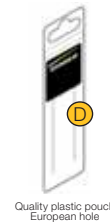

Quality plastic pouch
European hole

Ø	Lu	Lt	Ref.	Gencod	Qt.
1	12	34	728D01	3336600017351	1=10
1,5	18	40	728D01.5	3336600017368	1=10
2	24	49	728D02	3336600017375	1=10
2,5	30	57	728D02.5	3336600017399	1=10
2,8	33	61	728D02.8	3336600017412	1=10
3	33	61	728D03	3336600017429	1=10
3,2	36	65	728D03.2	3336600017443	1=10
3,5	39	70	728D03.5	3336600017474	1=10
4	43	75	728D04	3336600017504	1=10
4,2	43	75	728D04.2	3336600017528	1=10
4,5	47	80	728D04.5	3336600017559	1=10
5	52	86	728D05	3336600017597	1=10
5,2	52	86	728D05.2	3336600017610	1=10
5,5	57	93	728D05.5	3336600017627	1=10
6	57	93	728D06	3336600017634	1=10
6,2	63	101	728D06.2	3336600017658	1=10
6,5	63	101	728D06.5	3336600017665	1=10
7	69	109	728D07	3336600017672	1=10
7,5	69	109	728D07.5	3336600017702	1=10
8	75	117	728D08	3336600017719	1=10
8,5	75	117	728D08.5	3336600017740	1=10
9	81	125	728D09	3336600017757	1=10
10	87	133	728D10	3336600017771	1=10
11	94	142	728D11	3336600017795	1=5
12	101	151	728D12	3336600017818	1=5
13	101	151	728D13	3336600017832	1=5

5 to 10
PIECES



Quadropack
Round eyelet

ALL
SETS
PAGES 80-81

HSS-G Pro fully ground

Features

- Fully ground drill bit.
- 118° tip angle.
- Split point.
- Diameter tolerance h8.

Benefits

- Starting precision.
- Quick penetratin and easy drilling.

Applications

- Unalloyed and alloyed steels (up to 900N/mm²).



Ref.

735 713 DIN 340

712 DIN 1897

715 DIN 1897



Alloy steel

No-Alloy steel

Cast iron Graphite Laminaire

Cast iron Graphite Sphéroidale

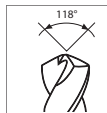

Long serie

Ø	Lu	Lt	Ref.	Gencod	Qt.
2	56	85	735D02	3336600012455	1
3	66	100	735D03	3336600011922	1
4	78	119	735D04	3336600011939	1
5	87	132	735D05	3336600011946	1
6	91	139	735D06	3336600011953	1
7	102	159	735D07	3336600012462	1
8	109	165	735D08	3336600011960	1
9	115	175	735D09	3336600012479	1
10	121	184	735D10	3336600011977	1
11	128	195	735D11	3336600012486	1
12	134	205	735D12	3336600012493	1
13	134	205	735D13	3336600012509	1

Quality plastic pouch
European hole

5 to 10
PIECES

Extra short serie

Ø	Lu	Lt	Ref.	Gencod	Qt.
2	12	38	712D02	3336600017948	1=10
2,5	14	43	712D02.5	3336600017993	1=10
3	16	46	712D03	3336600018051	1=10
3,2	18	49	712D03.2	3336600018075	1=10
3,3	18	49	712D03,3	3336600164710	1=10
3,5	20	52	712D03.5	3336600018105	1=10
4	22	55	712D04	3336600018150	1=10
4,2	22	55	712D04.2	3336600018174	1=10
4,5	24	58	712D04.5	3336600018204	1=10
5	26	62	712D05	3336600018228	1=10
5,2	26	62	712D05.2	3336600018242	1=10
5,5	28	66	712D05.5	3336600018259	1=10
6	28	66	712D06	3336600018273	1=10
6,2	31	70	712D06.2	3336600018280	1=10
6,5	31	70	712D06.5	3336600018297	1=10
7	34	74	712D07	3336600018310	1=10
7,5	34	74	712D07.5	3336600018334	1=10
8	37	79	712D08	3336600018358	1=10



Quadropack
Round eyelet

Double pointe

Ø	Lu	Lt	Ref.	Gencod	Qt.
3,1	12	49	715D03.1	3336600017849	1=10
3,2	12	49	715D03.2	3336600017856	1=10
3,3	12	49	715D03.3	3336600017863	1=10
3,5	13	52	715D03.5	3336600017870	1=10
4	14	55	715D04	3336600017887	1=10
4,1	14	55	715D04.1	3336600017894	1=10
4,2	14	55	715D04.2	3336600017900	1=10
5	17	62	715D05	3336600017917	1=10
5,1	17	62	715D05.1	3336600017924	1=10
5,2	17	62	715D05.2	3336600017931	1=10

Long serie

Ø	Lu	Lt	Ref.	Gencod	Qt.
2	56	85	713D02	3336600018464	1=10
2,5	62	95	713D02.5	3336600018518	1=10
3	66	100	713D03	3336600018563	1=10
3,2	69	106	713D03.2	3336600018587	1=10
3,5	73	112	713D03.5	3336600018617	1=10
4	78	119	713D04	3336600018662	1=10
4,2	78	119	713D04.2	3336600018686	1=10
4,5	82	126	713D04.5	3336600018716	1=10
5	87	132	713D05	3336600018761	1=10
5,2	87	132	713D05.2	3336600018785	1=10
5,5	91	139	713D05.5	3336600018815	1=10
5,8	91	139	713D05.8	3336600018846	1=10
6	91	139	713D06	3336600018860	1=10
6,2	97	148	713D06.2	3336600018884	1=10
6,5	97	148	713D06.5	3336600018914	1=10
7	102	156	713D07	3336600018969	1=10
7,5	102	156	713D07.5	3336600019027	1=10
8	109	165	713D08	3336600019072	1=10
8,5	109	165	713D08.5	3336600019126	1=10
9	115	175	713D09	3336600019171	1=10
9,5	115	175	713D09.5	3336600019225	1=10
10	121	184	713D10	3336600019270	1=10
11	128	195	713D11	3336600019294	1=5
12	134	205	713D12	3336600019317	1=5
13	134	205	713D13	3336600019331	1=5

Ø Max 12.7



735 - 713

712

715



Ref.

729

726



Alloy steel



No-Alloy steel



Cast iron Graphite Laminaire



Cast iron Graphite Sphéroidale

DIN 338

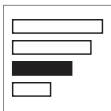
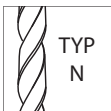
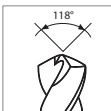

Ø Max 12.7

HSS Pro fully ground

Features

- Fully ground drill bit.
- 118° tip angle.
- Split point.
- Flute type N.
- Diameter tolerance h8.

Benefits

- Starting precision.
- Quick penetratin and easy drilling.

Applications

- Unalloyed and alloyed steels (up to 900N/mm²).



ALL SETS
PAGES 80-81



700C



718C



719C



745D



747D



206E

Short serie



Ø	Lu	Lt	Ref.	Gencod	Qt.
1	12	34	729D01	3336600007734	1=2
1,5	18	40	729D01.5	3336600007741	1=2
2	24	49	729D02	3336600007758	1=2
2,5	30	57	729D02.5	3336600007765	1=2
3	33	61	729D03	3336600007772	1=2
3,2	36	65	729D03.2	3336600007789	1=2
3,3	36	65	729D03.3	3336600012325	1=2
3,5	39	70	729D03.5	3336600007796	1=2
4	43	75	729D04	3336600007802	1=2
4,2	43	75	729D04.2	3336600007819	1=2
4,3	47	80	729D04.3	3336600012356	1=2
4,5	47	80	729D04.5	3336600007826	1=2
5	52	86	729D05	3336600007833	1=2
5,2	52	86	729D05.2	3336600007840	1
5,5	57	93	729D05.5	3336600007857	1
6	57	93	729D06	3336600007864	1
6,2	63	101	729D06.2	3336600012370	1
6,5	63	101	729D06.5	3336600007871	1
7	69	109	729D07	3336600007888	1
7,5	69	109	729D07.5	3336600007895	1
8	75	117	729D08	3336600007901	1

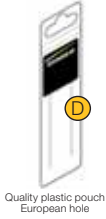

Quality plastic pouch
European hole

Ø	Lu	Lt	Ref.	Gencod	Qt.
8,5	75	117	729D08.5	3336600007918	1
9	81	125	729D09	3336600007925	1
9,5	81	125	729D09.5	3336600007932	1
10	87	133	729D10	3336600007949	1
10,5	87	133	729D10.5	3336600007956	1
11	94	142	729D11	3336600007963	1
11,5	94	142	729D11.5	3336600007970	1
12	101	151	729D12	3336600007987	1
12,5	101	151	729D12.5	3336600007994	1
13	101	151	729D13	3336600008007	1
13,5	108	160	729D13.5	3336600009547	1
14	108	160	729D14	3336600009554	1
14,5	114	169	729D14.5	3336600009561	1
15	114	169	729D15	3336600009578	1
15,5	120	178	729D15.5	3336600009585	1
16	120	178	729D16	3336600009592	1
16,5	125	184	729D16.5	3336600009608	1
17	125	184	729D17	3336600009615	1
18	130	191	729D18	3336600009639	1
19	135	198	729D19	3336600009653	1
20	140	205	729D20	3336600009677	1

2 to 10
PIECES

Short serie



Ø	Lu	Lt	Ref.	Gencod	Qt.
0,8	10	30	726D0.8	3336600022034	1=10
1	12	34	726D01	3336600010413	1=10
1.1	14	36	726D01.1	3336600010420	1=10
1.2	16	38	726D01.2	3336600010437	1=10
1.3	16	38	726D01.3	3336600010444	1=10
1.4	18	40	726D01.4	3336600010451	1=10
1,5	18	40	726D01.5	3336600010468	1=10
1.6	20	43	726D01.6	3336600010475	1=10
1.7	20	43	726D01.7	3336600010482	1=10
1.8	22	46	726D01.8	3336600010499	1=10
1.9	22	46	726D01.9	3336600010505	1=10
2	24	49	726D02	3336600010512	1=10
2.1	24	49	726D02.1	3336600010529	1=10
2.2	27	53	726D02.2	3336600010536	1=10
2.3	27	53	726D02.3	3336600010543	1=10
2.4	30	57	726D02.4	3336600010550	1=10
2,5	30	57	726D02.5	3336600010567	1=10
2.6	30	57	726D02.6	3336600010574	1=10
2.7	33	61	726D02.7	3336600010581	1=10
2,8	33	61	726D02.8	3336600010598	1=10
2.9	33	61	726D02.9	3336600010604	1=10
3	33	61	726D03	3336600010611	1=10
3.1	36	65	726D03.1	3336600010628	1=10
3,2	36	65	726D03.2	3336600010635	1=10
3,3	36	65	726D03.3	3336600010642	1=10
3.4	39	70	726D03.4	3336600010659	1=10
3,5	39	70	726D03.5	3336600010666	1=10
3,6	39	70	726D03.6	3336600010673	1=10
3,7	39	70	726D03.7	3336600010680	1=10
3,8	43	75	726D03.8	3336600010697	1=10
3,9	43	75	726D03.9	3336600010703	1=10
4	43	75	726D04	3336600010710	1=10
4.1	43	75	726D04.1	3336600010727	1=10
4,2	43	75	726D04.2	3336600010734	1=10
4,3	47	80	726D04.3	3336600010741	1=10
4,4	47	80	726D04.4	3336600010758	1=10
4,5	47	80	726D04.5	3336600010765	1=10
4,6	47	80	726D04.6	3336600010772	1=10
4,7	47	80	726D04.7	3336600010789	1=10
4,8	52	86	726D04.8	3336600010796	1=10
4,9	52	86	726D04.9	3336600010802	1=10
5	52	86	726D05	3336600010819	1=10
5.1	52	86	726D05.1	3336600010826	1=10
5,2	52	86	726D05.2	3336600010833	1=10
5,3	52	86	726D05.3	3336600010840	1=10
5,4	57	93	726D05.4	3336600010857	1=10
5,5	57	93	726D05.5	3336600010864	1=10
5,6	57	93	726D05.6	3336600010871	1=10
5,7	57	93	726D05.7	3336600010888	1=10
5,8	57	93	726D05.8	3336600010895	1=10
5,9	57	93	726D05.9	3336600010901	1=10
6	57	93	726D06	3336600010918	1=10
6.1	63	101	726D06.1	3336600010925	1=10
6,2	63	101	726D06.2	3336600010932	1=10
6,3	63	101	726D06.3	3336600010949	1=10
6,4	63	101	726D06.4	3336600010956	1=10



Quadropack
Round eyelet

Ø	Lu	Lt	Ref.	Gencod	Qt.
6,5	63	101	726D06.5	3336600010963	1=10
6,6	63	101	726D06.6	3336600010970	1=10
6,7	63	101	726D06.7	3336600010987	1=10
6,8	69	109	726D06.8	3336600010994	1=10
6,9	69	109	726D06.9	3336600011007	1=10
7	69	109	726D07	3336600011014	1=10
7.1	69	109	726D07.1	3336600011021	1=10
7,2	69	109	726D07.2	3336600011038	1=10
7,3	69	109	726D07.3	3336600011045	1=10
7,4	69	109	726D07.4	3336600011052	1=10
7,5	69	109	726D07.5	3336600011069	1=10
7,6	75	117	726D07.6	3336600011076	1=10
7,7	75	117	726D07.7	3336600011151	1=10
7,8	75	117	726D07.8	3336600011168	1=10
7,9	75	117	726D07.9	3336600011175	1=10
8	75	117	726D08	3336600011182	1=10
8.1	75	117	726D08.1	3336600011199	1=10
8,2	75	117	726D08.2	3336600011205	1=10
8,3	75	117	726D08.3	3336600011212	1=10
8,4	75	117	726D08.4	3336600011229	1=10
8,5	75	117	726D08.5	3336600011236	1=10
8,6	81	125	726D08.6	3336600011243	1=10
8,7	81	125	726D08.7	3336600011250	1=10
8,8	81	125	726D08.8	3336600011267	1=10
8,9	81	125	726D08.9	3336600011274	1=10
9	81	125	726D09	3336600011281	1=10
9.1	81	125	726D09.1	3336600011298	1=10
9,2	81	125	726D09.2	3336600011304	1=10
9,3	81	125	726D09.3	3336600011311	1=10
9,4	81	125	726D09.4	3336600011328	1=10
9,5	81	125	726D09.5	3336600011335	1=10
9,6	87	133	726D09.6	3336600011342	1=10
9,7	87	133	726D09.7	3336600011359	1=10
9,8	87	133	726D09.8	3336600011366	1=10
9,9	87	133	726D09.9	3336600011373	1=10
10	87	133	726D10	3336600011380	1=10
10,5	87	133	726D10.5	3336600011397	1=5
11	94	142	726D11	3336600011403	1=5
11,5	94	142	726D11.5	3336600011410	1=5
12	101	151	726D12	3336600011427	1=5
12,5	101	151	726D12.5	3336600011434	1=5
13	101	151	726D13	3336600011441	1=5
13,5	108	160	726D13.5	3336600011458	1=5
14	108	160	726D14	3336600011465	1=2
14,5	114	169	726D14.5	3336600011472	1=2
15	114	169	726D15	3336600011489	1=2
15,5	120	178	726D15.5	3336600011496	1=2
16	120	178	726D16	3336600011502	1=2
16,5	125	184	726D16.5	3336600011519	1=2
17	125	184	726D17	3336600011526	1=2
17,5	125	184	726D17.5	3336600011533	1=2
18	130	191	726D18	3336600011540	1=2
18,5	135	198	726D18.5	3336600011557	1=2
19	135	198	726D19	3336600011564	1=2
19,5	140	205	726D19.5	3336600011571	1=2
20	140	205	726D20	3336600011588	1=2

Ref.

769
750

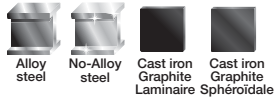

DIN 338

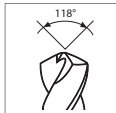

HSS

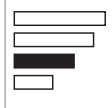

Ø Max 12.7

HSS Standard roll forged

Features

- Roll forged drill bit.
- 118° tip angle.
- Standard cutting.
- Flute type N.
- Diameter tolerance h8.

Benefits

- The rolling process gives the bit a degree of elasticity and reduces the risk of breaking.

Applications

- Unalloyed and alloyed steels (up to 900N/mm²), cast iron.



Ø	Lu	Lt	Ref.	Gencod	Qt.	Ø	Lu	Lt	Ref.	Gencod	Qt.
1	12	34	769D01	3336600008014	1=2	7	69	109	769D07	3336600008151	1
1,5	18	40	769D01.5	3336600008021	1=2	7,5	69	109	769D07.5	3336600008168	1
2	24	49	769D02	3336600008038	1=2	8	75	117	769D08	3336600008175	1
2,5	30	57	769D02.5	3336600008045	1=2	8,5	75	117	769D08.5	3336600008182	1
3	33	61	769D03	3336600008052	1=2	9	81	125	769D09	3336600008199	1
3,2	36	65	769D03.2	3336600008069	1=2	9,5	81	125	769D09.5	3336600008205	1
3,5	39	70	769D03.5	3336600008076	1=2	10	87	133	769D10	3336600008212	1
4	43	75	769D04	3336600008083	1=2	10,5	87	133	769D10.5	3336600008229	1
4,2	43	75	769D04.2	3336600008090	1=2	11	94	142	769D11	3336600008236	1
4,5	47	80	769D04.5	3336600008106	1=2	12	101	151	769D12	3336600008250	1
5	52	86	769D05	3336600008113	1=2	13	101	151	769D13	3336600008274	1
5,2	52	86	769D05.2	3336600016545	1	14	108	160	769D14	3336600008281	1
5,5	57	93	769D05.5	3336600008120	1	15	114	169	769D15	3336600008298	1
6	57	93	769D06	3336600008137	1	16	120	178	769D16	3336600008304	1
6,5	63	101	769D06.5	3336600008144	1						

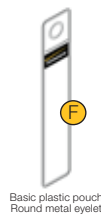

Basic plastic pouch
Round metal eyelet

Ø	Lu	Lt	Ref.	Gencod	Qt.	Ø	Lu	Lt	Ref.	Gencod	Qt.
2	24	49	750D02	3336600010017	1=10	7,5	69	109	750D07.5	3336600010154	1=10
2,5	30	57	750D02.5	3336600010024	1=10	8	75	117	750D08	3336600010161	1=10
3	33	61	750D03	3336600010031	1=10	8,5	75	117	750D08.5	3336600010178	1=10
3,2	36	65	750D03.2	3336600010048	1=10	9	81	125	750D09	3336600010185	1=10
3,5	39	70	750D03.5	3336600010055	1=10	9,5	81	125	750D09.5	3336600010192	1=10
4	43	75	750D04	3336600010062	1=10	10	87	133	750D10	3336600010208	1=10
4,2	43	75	750D04.2	3336600010079	1=10	11	94	142	750D11	3336600010222	1=5
4,5	47	80	750D04.5	3336600010086	1=10	12	101	151	750D12	3336600010246	1=5
5	52	86	750D05	3336600010093	1=10	13	101	151	750D13	3336600010260	1=5
5,2	52	86	750D05.2	3336600010109	1=10	14	108	160	750D14	3336600010284	1=2
5,5	57	93	750D05.5	3336600010116	1=10	15	114	169	750D15	3336600010307	1=2
6	57	93	750D06	3336600010123	1=10	16	120	178	750D16	3336600010321	1=2
6,5	63	101	750D06.5	3336600010130	1=10	18	130	191	750D18	3336600010369	1=2
7	69	109	750D07	3336600010147	1=10	20	140	205	750D20	3336600010406	1=2

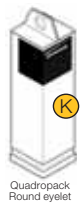

Quadropack
Round eyelet

ALL SETS
PAGES 80-81



750C



752C



775D



776D

HSS Cobalt TiAlN step drill bit

Features

- HSS TiAlN 5% Cobalt fully ground
- TiAlN nitride coating.
- 118° tip angle.
- Helicoidal flute.
- Deburring tool.
- Shank 3 flats.

Benefits

- The TiAlN coating extends the tool life.
- Helical flute improves penetration inside the material.
- Shank with three flats to guarantee optimum tightening in the chuck.
- The deburring tool makes it possible allows a clean hole.

Applications

- The step bit is used for drilling and bevelling sheet metal of fine materials of all types - steel, brass, PVC, cast iron, etc. - in a single operation.



Tube DIY

CAPACITE	Lt	D	d	l1	Ref.	Gencod	Qt.
4-5-6-7-8-9-10-11-12	79	12	6	5	500B	3336600144064	1
4-6-8-10-12-14-16-18-20	67	20	8	3	501B	3336600144071	1
4-6-8-10-12-14-16-18-20-22-24-26-28-30	100	30	10	4	502B	3336600144088	1

ALL SETS
PAGES 80-81



503C

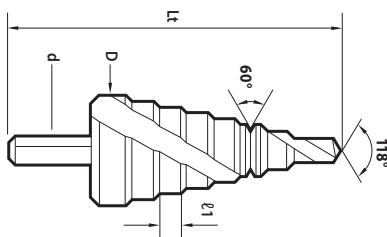

Ref.

500B
501B
502B

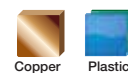
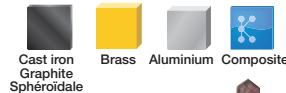
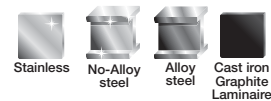

5% Co
TiAlN



Step drill bit

Features

- HSS fully ground
- 118° tip angle.
- Deburring tool.
- Straight shank

Benefits

- Easy sharpening thanks to its straight flute.

Applications

- Thickness ideal for drilling sheets and sheet materials up to a thickness of 2 mm and for thin pipes 3 mm max.
- Ideal for all drilling jobs in the fields of electricity and maintenance.



Tube DIY

CAPACITE	Lt	D	d	l1	Ref.	Gencod	Qt.
4-6-8-10-12-14-16-18-20	67	20	8	3	511B	3336600194076	1
4-6-8-10-12-14-16-18-20-22-24-26-28-30	100	30	10	4	512B	3336600194069	1
6-8-10-12-14-16-18-20-22-24-26-28-30-32-34-36-38	100	38	10	4	513B	3336600194311	1



513C

ALL SETS
PAGES 80-81

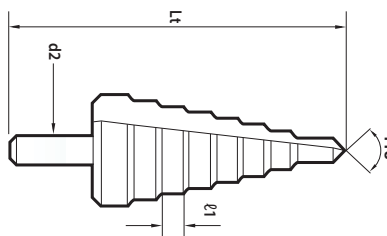

511B
512B
513B

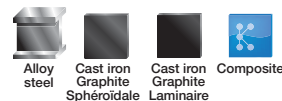

HSS



Ref.

865

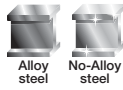

DIN 352



1/3 rough



2/3 split



3/3 end



867



DIN 376



827



Rectified taps & HSS gun taps

Applications

Ref 865 : Set of ground HSS hand taps for blind or through taps in alloyed or unalloyed steels.

Taps are made in three stages using an adjustable tap wrench : rough/intermediate/finishing.

Ref 867 : The GUN tap grants full through tapping in one step.



Ø drilling	Ø x Pas	Lu	Lt	Ref.	Gencod	Qt.	Pack
3 rectified HSS Taps set							
2,5	M3 x 0,50	11	40	865D03	3336600013056	1	X
3,3	M4 x 0,70	13	45	865D04	3336600013063	1	X
4,2	M5 x 0,80	16	50	865D05	3336600013070	1	X
5	M6 x 1	19	50	865D06	3336600013087	1	X
6	M7 x 1	19	50	865D07	3336600020276	1	X
6,8	M8 x 1,25	22	56	865D08	3336600013094	1	X
8,5	M10 x 1,50	24	70	865D10	3336600013100	1	X
10,2	M12 x 1,75	29	75	865D12	3336600020290	1	X
12	M14 x 2	30	80	865D14	3336600020306	1	X
14	M16 x 2	32	80	865D16	3336600020313	1	X
15,5	M18 x 2,50	40	95	865D18	3336600020320	1	X
Gun HSS Taps							
2,5	M3 x 0,50	11	56	867D03	3336600020368	1	I
3,3	M4 x 0,70	13	63	867D04	3336600020375	1	I
4,2	M5 x 0,80	16	70	867D05	3336600020382	1	I
5	M6 x 1	19	80	867D06	3336600020399	1	I
6,8	M8 x 1,25	22	90	867D08	3336600020405	1	I
8,5	M10 x 1,50	24	100	867D10	3336600020412	1	I
10,2	M12 x 1,75	29	110	867D12	3336600020429	1	I
12	M14 x 2	30	110	867D14	3336600020436	1	I
14	M16 x 2	34	110	867D16	3336600020443	1	I
Adjustable tap wrench							
N°1	M3 to 10			82701	3336600020580	1	E
N°2	M4 to 14			82702	3336600020597	1	E
N°3	M5 to 18			82703	3336600068667	1	E

Die

Applications

• With the help of the die holder, it may be used to make or restore an external thread.



825 826

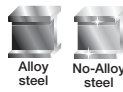

829



Ø x Pas	H	Ø	Ref.	Gencod	Qt.	Pack
Cage Ø 25,4						
M3 x 0,50	9	25,4	825D03	3336600020450	1	R
M4 x 0,70	9	25,4	825D04	3336600020467	1	R
M5 x 0,80	9	25,4	825D05	3336600020474	1	R
M6 x 1	9	25,4	825D06	3336600020481	1	R
M8 x 1,25	9	25,4	825D08	3336600020498	1	R
M10 x 1,50	9	25,4	825D10	3336600020504	1	R
Cage Ø 38,1						
M8 x 1,25	13	38,1	826D08	3336600020511	1	R
M10 x 1,5	13	38,1	826D10	3336600020528	1	R
M12 x 1,75	13	38,1	826D12	3336600020535	1	R
M14 x 2	13	38,1	826D14	3336600020542	1	R
M16 x 2	13	38,1	826D16	3336600020559	1	R
M18 x 2,5	13	38,1	826D18	3336600020566	1	R
M20 x 2,5	13	38,1	826D20	3336600020573	1	R
Die holder						
Cage 25,4			829D25.4	3336600020603	1	E
Cage 38,1			829D38.1	3336600020610	1	E



078E



076E

Screw extractor

Ref.

634



Features

- Forged tool.
- High-quality vanadium chromium steel.
- Reversed pitch : left-hand pitch.
- Square shank.

Applications

- Ideal for removing metric screws with broken or damaged heads.

Advices

- Drill the broken screw with the HSS-C 5% cobalt (731-700) or HSS G3 (702-703).
- For the tool holder, use an adjustable tap wrench (part no. 827), use an adjustable spanner for very large diameters and an open-ended spanner or a ratchet spanner for small spaces.

ALL SETS
PAGES 80-81

x5



U5050153

x6



U5050163

N° extractor	Ref.	Gencod	Qt.
1	634010	3336600186002	1
2	634020	3336600186019	1
3	634030	3336600186026	1
4	634040	3336600186033	1
5	634050	3336600186040	1
6	634060	3336600186057	1
7	634070	3336600186064	1
8	634080	3336600186071	1

Quality plastic pouch
European hole

x8



U5050183

Screw to extract	Ø Drilling	N° Extractor	SW mm	Adjustable tap wrench	Adjustable spanner
M3-6	2.50	1	3.20	1	oui
M6-8	3	2	4	1-2	oui
M8-11	4.50	3	5.20	1-2	oui
M11-14	6	4	6.40	2-3	oui
M14-18	8	5	8.85	3	oui
M18-24	11	6	11.80	3	oui
M24-33	14	7	15	-	oui
M33-50	21	8	20	-	oui

HSS 90° Countersink

Ref.

504

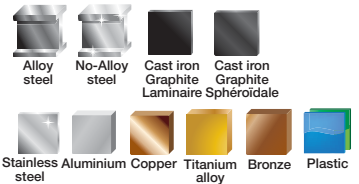

Features

- HSS (504) three teeth countersink or HSS-C 5% cobalt three teeth countersink (505C).
- 90° angle.
- "Spoon" cutting.

Benefits

- Cobalt increases the heating resistance and allows the working on hard steels and stainless steel.
- Wide flutes improve the removal of chips.
- 'Spoon' cutting avoid burrs.

Applications

- The countersink with three teeth is used for bevelling or deburring a variety of materials such as steels, alloys, plastic or synthetic materials.

Ø	Lu	Ref.	Gencod	Qt.
6,3	45	504D06.3	3336600173453	1
8,3	50	504D08,3	3336600166738	1
10,4	50	504D10,4	3336600166745	1
12,4	56	504D12,4	3336600166752	1
16,5	56	504D16,5	3336600166769	1
20,5	63	504D20,5	3336600166776	1



DIY tube
European hole

DIN 335C



HSS

HSS-E
5 % Co



504C



505C

5% Co

ALL SETS
PAGES 80-81



Ref.

DIN 338 **D2409**

DIN 340 **D2418**

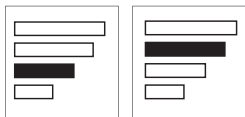
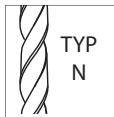
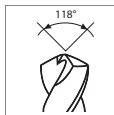

TCT HSS drill bit

2 lips

Features

- Cut straight : 6°.
- Flute straight : 25°.
- Quantity of Lip : 2.
- Flute type N.
- Point : AF1.
- Very high-temperature brazing.
- High speed steel, Carbide tip K20.

Applications

- Alloy steel, Non-alloy steel, Cast iron, Cast iron, Stainless steel, Aluminum, Titanium alloy, Copper, Plastic.

Ø A > h7
Ø B > h7
LT > ±1
Lt > ±1

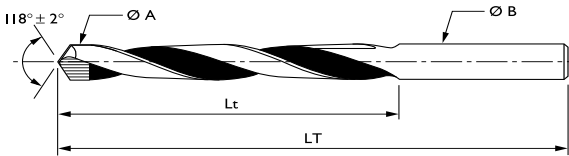

Short serie													
Ø	Lu	Lt	Ref.	Gencod	Qt.		Ø	Lu	Lt	Ref.	Gencod	Qt.	
1,5	18	40	D2409D0150	3336600121287	1		9,5	81	125	D2409D0950	3336600122086	1	
2	24	49	D2409D0200	3336600121331	1		10	87	133	D2409D1000	3336600122130	1	
2,5	30	57	D2409D0250	3336600121386	1		10,5	87	133	D2409D1050	3336600122154	1	
2,8	33	61	D2409D0280	3336600121416	1		11	94	142	D2409D1100	3336600122161	1	
3	33	61	D2409D0300	3336600121430	1		11,5	94	142	D2409D1150	3336600122185	1	
3,2	36	65	D2409D0320	3336600121454	1		12	101	151	D2409D1200	3336600122192	1	
3,3	36	65	D2409D0330	3336600121461	1		12,5	101	151	D2409D1250	3336600122215	1	
3,5	39	70	D2409D0350	3336600121485	1		13	101	151	D2409D1300	3336600122222	1	
4	43	75	D2409D0400	3336600121539	1		13,5	108	160	D2409D1350	3336600122239	1	
4,2	43	75	D2409D0420	3336600121553	1		14	108	160	D2409D1400	3336600122246	1	
4,5	47	80	D2409D0450	3336600121584	1		15	114	169	D2409D1500	3336600122260	1	
4,8	52	86	D2409D0480	3336600121614	1		15,5	120	178	D2409D1550	3336600122277	1	
5	52	86	D2409D0500	3336600121638	1		16	125	184	D2409D1600	3336600122284	1	
5,2	52	86	D2409D0520	3336600121652	1		16,5	125	184	D2409D1650	3336600122291	1	
5,5	57	93	D2409D0550	3336600121683	1		17	125	184	D2409D1700	3336600122307	1	
6	57	93	D2409D0600	3336600121737	1		17,5	130	191	D2409D1750	3336600122314	1	
6,5	63	101	D2409D0650	3336600121782	1		18	130	191	D2409D1800	3336600122321	1	
7	69	109	D2409D0700	3336600121836	1		18,5	135	198	D2409D1850	3336600122338	1	
7,5	69	109	D2409D0750	3336600121881	1		19	135	198	D2409D1900	3336600122345	1	
8	75	117	D2409D0800	3336600121935	1		19,5	140	205	D2409D1950	3336600122352	1	
9	81	125	D2409D0900	3336600122031	1		20	140	205	D2409D2000	3336600122369	1	

Long serie													
Ø	Lu	Lt	Ref.	Gencod	Qt.		Ø	Lu	Lt	Ref.	Gencod	Qt.	
1,8	53	80	D2418D0180	3336600129894	1		10	121	184	D2418D1000	3336600130593	1	
2	56	85	D2418D0200	3336600129917	1		10,5	121	184	D2418D1050	3336600130609	1	
2,5	62	95	D2418D0250	3336600129962	1		11	128	195	D2418D1100	3336600130616	1	
3	66	100	D2418D0300	3336600130012	1		11,5	128	195	D2418D1150	3336600130623	1	
3,5	73	112	D2418D0350	3336600130067	1		12	134	205	D2418D1200	3336600130630	1	
4	78	119	D2418D0400	3336600130111	1		12,5	134	205	D2418D1250	3336600130647	1	
4,5	82	126	D2418D0450	3336600130166	1		13	134	205	D2418D1300	3336600130654	1	
5	87	132	D2418D0500	3336600130210	1		13,5	140	214	D2418D1350	3336600130661	1	
5,5	91	139	D2418D0550	3336600130265	1		14	140	214	D2418D1400	3336600130678	1	
6	91	139	D2418D0600	3336600130319	1		14,5	144	220	D2418D1450	3336600130685	1	
6,5	97	148	D2418D0650	3336600130364	1		15	144	220	D2418D1500	3336600130692	1	
7	102	156	D2418D0700	3336600130418	1		16	149	227	D2418D1600	3336600130708	1	
7,5	102	156	D2418D0750	3336600130463	1		17	154	235	D2418D1700	3336600130715	1	
8	109	165	D2418D0800	3336600130517	1		18	158	241	D2418D1800	3336600130722	1	
8,5	109	165	D2418D0850	3336600130562	1		19	162	247	D2418D1900	3336600130739	1	
9	115	175	D2418D0900	3336600130579	1		20	166	254	D2418D2000	3336600130746	1	
9,5	115	175	D2418D0950	3336600130586	1								

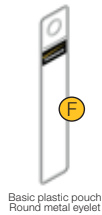

Basic plastic pouch
Round metal eyelet



100% HSS

1 METER
DYSPLAY



Unit range

Rack Presentation

HSS Cobalt 5% drill bit - ref. 731
HSS G3 drill bit - ref. 702
HSS Pro drill bit - ref. 729

Set range

Quadropack range

HSS Cobalt 5% drill bit - ref. 700
HSS G3 drill bit - ref. 703
HSS Pro drill bit - ref. 726

Designation	Ref.	Gencod
1M SALES SHELF	GOND1000	3336609000019
LUMINAR PEDIMENT FOR GOND 1METER	FRONTON	3336609004277
METAL FOR LUMINAR PEDIMENT	B00434	
ELECTRIC CABLE FOR LUMINAR PEDIMENT	CORDON	3336600187528
ADJUSTABLE RACK WITH 20 DOUBLE HOOKS, 1M	RAT1000DOUBLE	3336609002211
1M STAY FOR 1M SALES SHELF	BAR1000	3336609000057
DISPLAY CASE 1M FOR SETS	M00157	3336609005274
STORAGE UNIT WITH 2 DRAWERS	M00170	3336609006806
MAGNET HSS G3	B00357	-
MAGNET HSS COBALT	B00358	-
MAGNET HSS PRO	B00359	-



Stand counter

For boxes 19 or 25 pcs
Ref. C00090
Display stand delivered flat

P.O.S ADVERTISING
TO SPUR SALES



Floor P.O.S
advertising display

Holds up to 40 boxes
Ref. C00108



HSS Stand
counter

26 compartments
Ref. M00087 Opening on Front / Rear,
with key lock

METAL

HSS Standard



HSS Pro



HSS Cobalt 5%



HSS Tin









Features	Pcs	Type	Composition	Ref.	Gencod
HSS STANDARD	6	set	HSS Standard 02-3-4-5-6-8mm	750C	333660007093
HSS STANDARD	10	set	HSS Standard 01-10mm	752C	333660007116
HSS STANDARD	19	metal set	HSS Standard 01 to 10mm par 0,5mm	775D	333660025745
HSS STANDARD	25	metal set	HSS Standard 01-13mm / 0,5mm	776D	333660025752
HSS COBALT 5%	6	solo	HSS Cobalt 5% 02-3-4-5-6-8mm	706C	333660007185
HSS COBALT 5%	10	duo	HSS Cobalt 5% 01-10mm	720C	3336600083547
HSS COBALT 5%	13	duo	HSS Cobalt 5% 01,5-6,5mm / 0,5mm +3,2-4,2mm	721C	3336600083530
HSS COBALT 5%	19	set	HSS Cobalt 5% 01-10mm / 0,5mm	708D	3336600182226
HSS COBALT 5%	25	set	HSS Cobalt 5% 01-13mm / 0,5mm	707D	3336600160408
HSS PRO	19	metal set	HSS Pro 01-10 / 0,5mm	745D	333660025769
HSS PRO	25	metal set	HSS Pro 01-13 / 0,5mm	747D	333660025776
HSS PRO	6	solo	HSS Pro 02-3-4-5-6-8mm	700C	333660007123
HSS PRO	10	duo	HSS Pro 01-10mm	718C	3336600083561
HSS PRO	13	duo	HSS Pro 01,5-6,5mm / 0,5mm +3,2-4,2mm	719C	3336600083554
HSS PRO	170	case	HSS Pro 01-10 / 0,5mm	206E	3336600182219
HSS TITANE	6	solo	HSS Titane 02-3-4-5-6-8mm	707C	333660007192
HSS TITANE	10	duo	HSS Titane 01-10mm	722C	3336600084032
HSS TITANE	13	duo	HSS Titane 01,5-6,5mm / 0,5mm +3,2-4,2mm	723C	3336600084049



Features	Pcs	Type	Composition	Ref.	Gencod
HSS G3	19	set	HSS G3 01-10mm / 0,5mm	705D	3336600160385
HSS G3	25	set	HSS G3 01-13mm / 0,5mm	706D	3336600160392
HSS G3	170	case	HSS G3 01-10mm / 0,5mm	203E	3336600181090
TCT HSS	6	set	Tct HSS 03-4-5-6-8-10mm	507C	3336600157699
TCT	24	set	Tct HSS D2409 01-13mm / 0,5mm	508C	3336600168145
DIE & TAP	31	case	Tap M3-4-5-6-8-10-12 Die M3-4-5-6-8-10-12 -1 + Tap wrench + 1 Die holder + 1 tool	078E	3336600167537
TAP & HSS DRILL BIT	15	set	HSS drill bit 02,5-3,3-4,2-5-6,8-8,5-10,2mm Tap M3-4-5-6-8-10-12 + 1 Tap wrench	076E	3336600168152
COUNTERSINK	5	set	HSS 90° Cobalt 08,3-10,4-12,4-16,5-20,5 mm	505C	3336600144118
COUNTERSINK	5	set	HSS 90° 08,3-10,4-12,4-16,5-20,5 mm	504C	3336600144101
SET EXTRACTOR	5	set	Extractor 01 to 5	U5050153	4019321501536
SET EXTRACTOR	6	set	Extractor 01 to 6	U5050163	4019321501635
SET EXTRACTOR	8	set	Extractor 01 to 8	U5050183	4019321501833
STEP DRILL BIT	3	set	Step drill bit 5% Cobalt TiAln 4 to 12 - 4 to 20 - 4 to 30	503C	3336600144095
STEP DRILL BIT	3	set	Step drill bit 4 to 12 - 4 to 30 - 6 to 38	513C	3336600194083



Drilling wood guide

Ref.	Designation	Attachement	Origine	Benefits	Page
912 913 941 946	Auger bit Super Pro	Hex shank		<ul style="list-style-type: none"> • Structural work • Deep drilling • Speed • Robustness 	84
942 943	Auger bit Super Pro	SDS-plus		<ul style="list-style-type: none"> • Structural work • Deep drilling • Speed • Robustness 	84
904	Flat bit	Quick lock		<ul style="list-style-type: none"> • The work of electricity, install lock • Speed, cleanliness of cut & increased rigidity 	85
934	Woodmax Forstner bit	3 shank		<ul style="list-style-type: none"> • The work of joineries (windows, doors...) • Net Holes & precise, anti-overheating 	86
936	Carbide woodmax Forstner bit	3 shank		<ul style="list-style-type: none"> • The work of joineries (windows, doors...) • Long Life • Wood Special Very hard 	86
928	Disc plug cutter	Straight shank		<ul style="list-style-type: none"> • Achievement of plugs of wood • Precise Cutting 	87
723M 722M	Formwork drill bit	Straight shank SDS-plus		<ul style="list-style-type: none"> • Drill hole multi-layers • Ideal for the renovation work, achievement of formwork • Great length 	87
910	4 points drill bit	Straight shank		<ul style="list-style-type: none"> • Calibrated Hole and clean, fast and precise. 	88
915 918	3 points drill bit	Straight shank		<ul style="list-style-type: none"> • Calibrated Hole and clean, up to 410 mm 	88
902	Decking kit	Quick lock		<ul style="list-style-type: none"> • Decking special • Drilling and routing for housing of the screw head • Adjustable depth 	89
981	Brad point bit	Quick lock		<ul style="list-style-type: none"> • Screwdriver Special 	61

Exotic Wood	Hard wood	Low density wood	Laminate	Plywood	Wooden plate	Plaster Plat	Composite
Optimal	Optimal	Optimal	Optimal	Occasional	Occasional	Occasional	Occasional
Optimal	Optimal	Optimal	Optimal	Occasional	Occasional	Occasional	Occasional
Optimal	Optimal	Optimal	Optimal	Optimal	Occasional	Occasional	Occasional
Optimal	Optimal	Optimal	Optimal	Optimal	Optimal	Occasional	Occasional
Optimal	Optimal	Optimal	Optimal	Occasional	Optimal	Occasional	Optimal
Occasional	Optimal	Optimal	Optimal	Occasional	Occasional	Occasional	Occasional
Occasional	Optimal	Optimal	Occasional	Occasional	Occasional	Optimal	Occasional
Optimal	Optimal	Optimal	Occasional	Occasional	Occasional	Occasional	Occasional
Optimal	Optimal	Optimal	Occasional	Optimal	Occasional	Optimal	Occasional
Optimal	Optimal	Optimal	Occasional	Occasional	Occasional	Occasional	Occasional
Occasional	Optimal	Optimal	Occasional	Occasional	Occasional	Occasional	Occasional

Optimal
 Occasional

Ref.

912 913
946 941
942 943

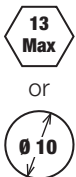

Features

- Self-centering head.
- Accurate cutting for perfect net hole.
- Rectified and polished land.
- Heat treatment on all length.
- Compatible SDS-plus or hex-shank.

Benefits

- Deep drilling.
- Fast drilling.
- Net cutting.
- Friction limited.
- Prevent over-heating.

FAST AND STRONG

Auger bit Super Pro

Compatible SDS-plus ou Hex-shank

Ø	Lu	Lt	Ref.	Gencod	Qt.
Attachment HEXA		L 235			
4*	100	180	912D04	3336600153066	1
6*	160	235	912D06	3336600153073	1
8	160	235	912D08	3336600153080	1
10	160	235	912D10	3336600153097	1
12	160	235	912D12	3336600153103	1
14	155	235	912D14	3336600153110	1
16	155	235	912D16	3336600153127	1
18	155	235	912D18	3336600153134	1
20	155	235	912D20	3336600153141	1
22	150	235	912D22	3336600153158	1
24	155	235	912D24	3336600152854	1
26	155	235	912D26	3336600152830	1
28	150	235	912D28	3336600152847	1
32	150	235	912D32	3336600153387	1

Attachment HEXA		L 460			
8	375	460	913D08	3336600152861	1
10	380	460	913D10	3336600152878	1
12	380	460	913D12	3336600152885	1
14	380	460	913D14	3336600152892	1
16	380	460	913D16	3336600152908	1
17	380	460	913D17	3336600153042	1
18	380	460	913D18	3336600152915	1
20	380	460	913D20	3336600152922	1
22	380	460	913D22	3336600152939	1
24	380	460	913D24	3336600152946	1
26	380	460	913D26	3336600152953	1
28	380	460	913D28	3336600152960	1
30	370	460	913D30	3336600153059	1
32	370	460	913D32	3336600152977	1

Attachment HEXA		L 600			
12	530	600	941D12	3336600153165	1
14	525	600	941D14	3336600153172	1
16	525	600	941D16	3336600153189	1
18	520	600	941D18	3336600153196	1
20	520	600	941D20	3336600153202	1
22	520	600	941D22	3336600153219	1
24	520	600	941D24	3336600153226	1

Attachment HEXA		L 1080			
12	1000	1080	946D12	3336600186668	1
14	1000	1080	946D14	3336600186675	1
16	1000	1080	946D16	3336600186682	1
18	990	1080	946D18	3336600186699	1
20	990	1080	946D20	3336600186705	1
22	990	1080	946D22	3336600186712	1
24	990	1080	946D24	3336600186729	1
26	990	1080	946D26	3336600186736	1
28	980	1080	946D28	3336600186743	1
30	980	1080	946D30	3336600186750	1
32	980	1080	946D32	3336600186767	1

Compatible SDS-plus		L 235			
6	100	200	942D06	3336600153233	1
8	100	200	942D08	3336600153240	1
10	160	235	942D10	3336600153257	1
12	160	235	942D12	3336600153264	1
14	155	235	942D14	3336600153271	1
16	155	235	942D16	3336600153288	1
18	155	235	942D18	3336600153295	1
20	155	235	942D20	3336600153301	1

Compatible SDS-plus		L 400			
10	320	400	943D10	3336600153318	1
12	320	400	943D12	3336600153325	1
14	320	400	943D14	3336600153332	1
16	320	400	943D16	3336600153339	1
18	320	400	943D18	3336600153356	1
20	320	400	943D20	3336600153363	1
22	320	400	943D22	3336600153370	1
24	320	400	943D24	3336600178274	1
26	320	400	943D26	3336600178281	1
28	320	400	943D28	3336600178298	1



ALL SETS
PAGES 90-91



943C



913C

Straight shank

Flat bit

Features

- Ground chipbreaker.
- Rectified centering point.
- High resistance steel.
- Dual-colour bit.
- Reinforced rigidity of the axis.
- Quick-lock 6.35.

Benefits

- Quick, clean and splinter-free drilling.
- Accurate cutting.
- Increased rigidity.
- Optimum hold in the chuck.
- Greater compatibility with hardware.

Applications

- For the rapid drilling and forming of large diameters, in all types of wood.
- Also suitable for most types of wood and wood-based panels.
- Ideal for the installation of locks, electrical and plumbing work.

Ø	Lt.	Ref.	Gencod	Qt.
6	152	904D06	3336600028715	1
8	152	904D08	3336600009844	1
10	152	904D10	3336600009851	1
12	152	904D12	3336600009868	1
13	152	904D13	3336600028722	1
14	152	904D14	3336600009875	1
16	152	904D16	3336600009882	1
18	152	904D18	3336600009899	1
19	152	904D19	3336600028739	1
20	152	904D20	3336600009905	1
22	152	904D22	3336600009912	1
24	152	904D24	3336600009929	1
25	152	904D25	3336600009936	1
26	152	904D26	3336600009943	1
28	152	904D28	3336600009950	1
30	152	904D30	3336600009967	1
32	152	904D32	3336600009974	1
35	152	904D35	3336600009981	1

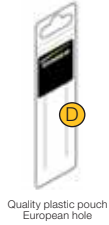

Ref.
904

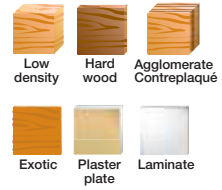

Flat bit extension

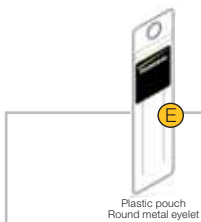

Att.	Lt.	Ref.	Gencod	Qt.
Hexa	270	906	3336600012110	1

906



Expandable bit

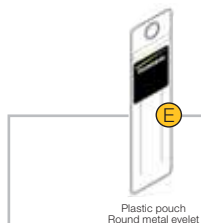

Ø	Lt.	Ref.	Gencod	Qt.
Ø 15 to 45	122	908	3336600012127	1

908



Ref.

934

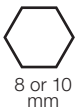
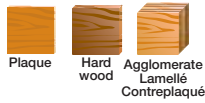

Forstner Woodmax bit

PREVENTS HEATING

Features

- Self-centering point.
- 2 central blades.
- 2 cutting blades on the circumference.
- Specific teeth geometry.
- Straight shank.
- 3-shank.

Benefits

- Perfect cutting and without any splinters.
- Higher penetration than classic drill.
- Limited overheating.

ALL SETS
PAGES 90-91



Ø	Ø	Lu	Lt	Ref.	Gencod	Qt.	
	15	8	57	90	934D15	3336600145474	1
	16	8	57	90	934D16	3336600145481	1
	18	8	57	90	934D18	3336600145498	1
	20	8	57	90	934D20	3336600145504	1
	22	10	57	90	934D22	3336600145511	1
	25	10	57	90	934D25	3336600145528	1
	26	10	57	90	934D26	3336600145535	1
	30	10	57	90	934D30	3336600145542	1
	35	10	57	90	934D35	3336600145559	1
	40	10	57	90	934D40	3336600145566	1
	45	10	57	90	934D45	3336600145573	1
	50	10	57	90	934D50	3336600145580	1



Or



Twistpack

936

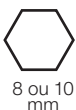
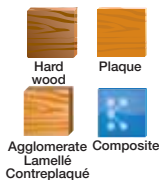

Forstner Woodmax carbide bit

**SPECIAL VERY HARD WOOD
CARBIDE TEETH**

Features

- Self-centering point.
- 2 central blades.
- 2 cutting blades on the circumference.
- Specific teeth geometry.
- Straight shank.
- 3-shank.

Benefits

- Long life.
- Perfect cutting without any splinters.
- Hard wood recommended.

Ø	Ø	Lu	Lt	Ref.	Gencod	Qt.	
	15	8	57	90	936D15	3336600145658	1
	20	8	57	90	936D20	3336600145665	1
	22	10	57	90	936D22	3336600146037	1
	25	10	57	90	936D25	3336600145672	1
	26	10	57	90	936D26	3336600146044	1
	30	10	57	90	936D30	3336600145689	1
	32	10	57	90	936D32	3336600146051	1
	35	10	57	90	936D35	3336600145696	1
	40	10	57	90	936D40	3336600145702	1
	45	10	57	90	936D45	3336600146068	1
	50	10	57	90	936D50	3336600146075	1



Or



Twistpack

Disc plug cutter

Features

- Multiple blades.
- Double extraction for plugs from 40mm to 75mm.
- Straight shank.

Benefits

- Perfect cutting.
- No vibration.
- Evacuation of plug on the both sides.

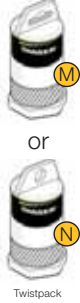

Ø	Ø	Ø Ext	Lu	Lt	Ref.	Gencod	Qt.
10	13	20	70	140	928D10	3336600145719	1
15	13	25	70	140	928D15	3336600145726	1
20	13	30	70	140	928D20	3336600145733	1
25	13	37	70	140	928D25	3336600145740	1
30	13	42	70	140	928D30	3336600145757	1
35	13	49	70	140	928D35	3336600145764	1
50	16	64	70	140	928D50	3336600160378	1

Ref.

928

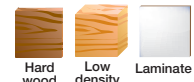

Made in Germany

13 mm
or 16 mm



Formwork drill bit

Compatible SDS-plus or straight shank

MULTI LAYERS DRILLING

Features

- Sharpening 118°.
- HSS quality.
- Straight shank (Ø10 mm).

Benefits

- Big length bit for multiple use.
- Sandwich panel.

Applications

- Removal works, plumbers, electricians, all type of contractors, industrial buildings,...



Ø	Lu	Lt	Ref.	Gencod	Qt.	Pack
Straight shank						
8	360	400	723MD08	3336600116634	1	E
10	360	400	723MD10	3336600116641	1	E
12	360	400	723MD12	3336600116658	1	E
14	360	400	723MD14	3336600116665	1	E
16	360	400	723MD16	3336600116672	1	E
18	360	400	723MD18	3336600116689	1	E
20	360	400	723MD20	3336600116696	1	E
24	360	400	723MD24	3336600116702	1	E
Compatible SDS-plus						
10	340	400	722MD10	3336600164550	1	A
12	340	400	722MD12	3336600164567	1	A
14	340	400	722MD14	3336600164574	1	A
16	340	400	722MD16	3336600164581	1	A
18	340	400	722MD18	3336600164598	1	A
20	340	400	722MD20	3336600164604	1	A
24	340	400	722MD24	3336600164611	1	A

723M
722M



Ø 10

Extension

3 pans

ØAtt. (A)	ØInt. (B)	Lu	Lt	Ref.	Gencod	Qt.
10	8	16	130	937D08L0130	3336600145771	1
10	10	16	130	937D10L0130	3336600145788	1

937

Made in Germany

10 mm



Depth adjuster collars (x5)



Pcs.	Ø int.	Ref.	Gencod	Qt.
5	Ø4/5/6/8/10	938C	3336600145795	1

938C

Made in Germany

Wood countersink

Ø int.	Ø ext.	Lt	Ref.	Gencod	Qt.
3	16	25	939D03	3336600145801	1
4	16	25	939D04	3336600145818	1
5	16	25	939D05	3336600145825	1

939

Made in Germany



* with key

Ref.

910

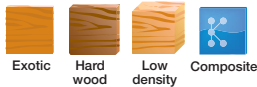

4 Pro drill bit

Features

- Self-centering point.
- 3 cutting edges.
- 3 lands reducing frictions.
- Straight shank.

Benefits

- Speed.
- Reduce frictions.
- Long life.
- Perfect holes.



ALL SETS
PAGES 90-91



Ø	Lu	Lt	Ref.	Gencod	Qt.
3	22	62	910D03	3336600155138	1
4	35	75	910D04	3336600154537	1
5	46	86	910D05	3336600147348	1
6	53	93	910D06	3336600147355	1
8	77	117	910D08	3336600147362	1
10	93	133	910D10	3336600147379	1
12	111	151	910D12	3336600147386	1

915 918

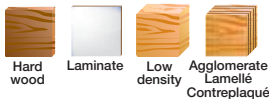

3 points Pro drill bit

Features

- Self-centering point.
- 2 cutting edges.
- Wide lands.
- Straight shank.

Benefits

- Precision.
- Perfect cutting.
- Performance.



ALL SETS
PAGES 90-91



Ø	Lu	Lt	Ref.	Gencod	Qt.
Short serie					
3	21	61	915D03	3336600011984	1
4	35	75	915D04	3336600011991	1
5	46	86	915D05	3336600012004	1
6	53	93	915D06	3336600012011	1
7	69	109	915D07	3336600012028	1
8	77	117	915D08	3336600012035	1
9	85	125	915D09	3336600012516	1
10	93	133	915D10	3336600012042	1
11	102	142	915D11	3336600013124	1
12	111	151	915D12	3336600012059	1
13	111	151	915D13	3336600012066	1
L240					
6	200	240	918D06	3336600012073	1
8	200	240	918D08	3336600012080	1
10	200	240	918D10	3336600012097	1
12	200	240	918D12	3336600012103	1
14	200	240	918D14	3336600012523	1
16	200	240	918D16	3336600012530	1
L450					
18	410	450	918D18	3336600012547	1
20	410	450	918D20	3336600012554	1

Decking kit

Special hard and exotical woods

Ref.

902



Hard wood



Exotic

Features

Complet kit :

- 3 x Ø4mm bits
- One 45° chamfer - carbide plates - Ø4mm quick lock attachment
- One "low friction" depth stop
- One double hex wrench
- Ref 911D04 - Spare drill bits

Benefits

- Screw Compatible from Ø4,5 to 6mm.
- Chamfer bit with carbide plates for a longer service life.
- The metal depth stop is very robust. Its freely rotating plastic ring stops on contact with the piece of wood, avoiding any marking of the planks.
- The drilling and chamfering depths can be accurately adjusted. The user can easily set the drilling depth without even having to remove the depth stop.
- This set guarantees clean and even work when installing hard wood decking.

Applications

- When lots of holes need to be drilled while building decking with exotics woods. This set allows you to pre-drill calibered holes for the used screws, and hide their heads in the same time thanks to the auto-ajusting carbide countersink. The SPECIAL DECKING DRILLING-CHAMFERING SET is specifically designed for this type of work.

Advices

- The harder wood, the closer the diameter of the hole must be to that of the screw. Pre-drillings is recommended for hard woods. For the best dust removal and increased service life, adjust the bottom of the bit helix to the clearance of the chamfer bit.



6.35

see our
video on
YouTube

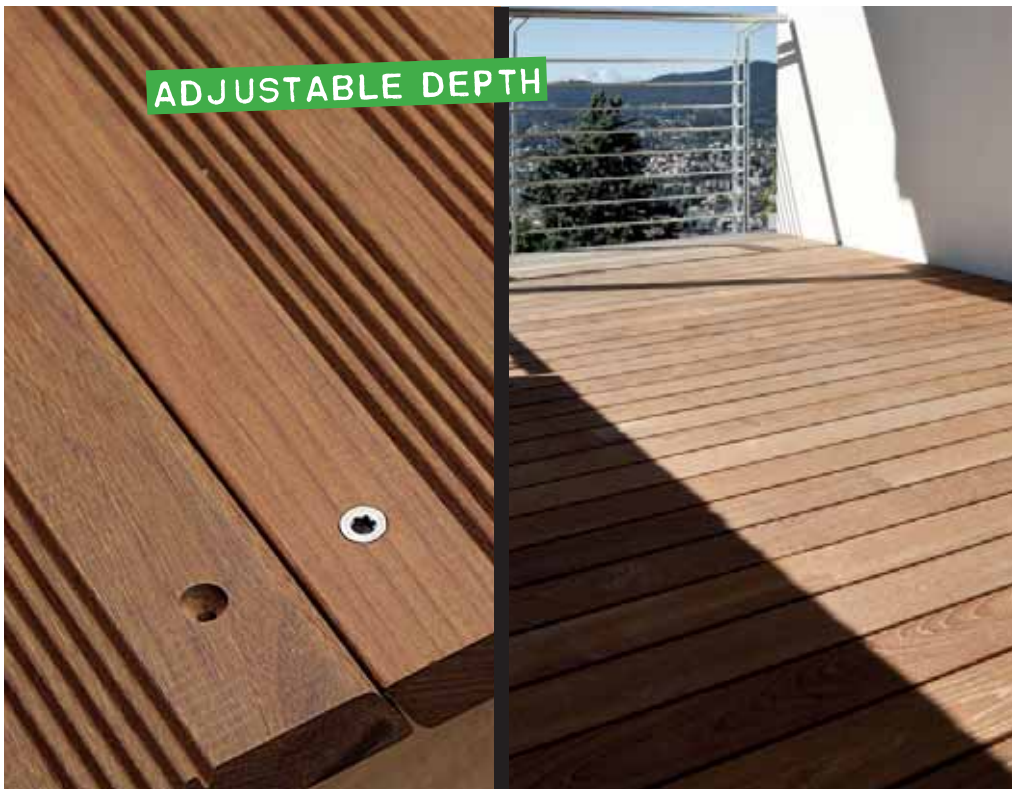

ADJUSTABLE DEPTH

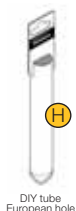

DIY tube
European hole



Twistpack

Ø	Ref.	Gencod	Qt.	Pack
Decking kit				
4	902D04	3336600173842	1	M
4.5	902D04.5	3336600197344	1	M
Decking drill bit Ø4 (x3pcs)				
4	911D04	3336600173859	1	H
4.5	911D04.5	3336600187351	1	H

WOOD



925C



905D



907B

917B

910D



902D04

902D04.5

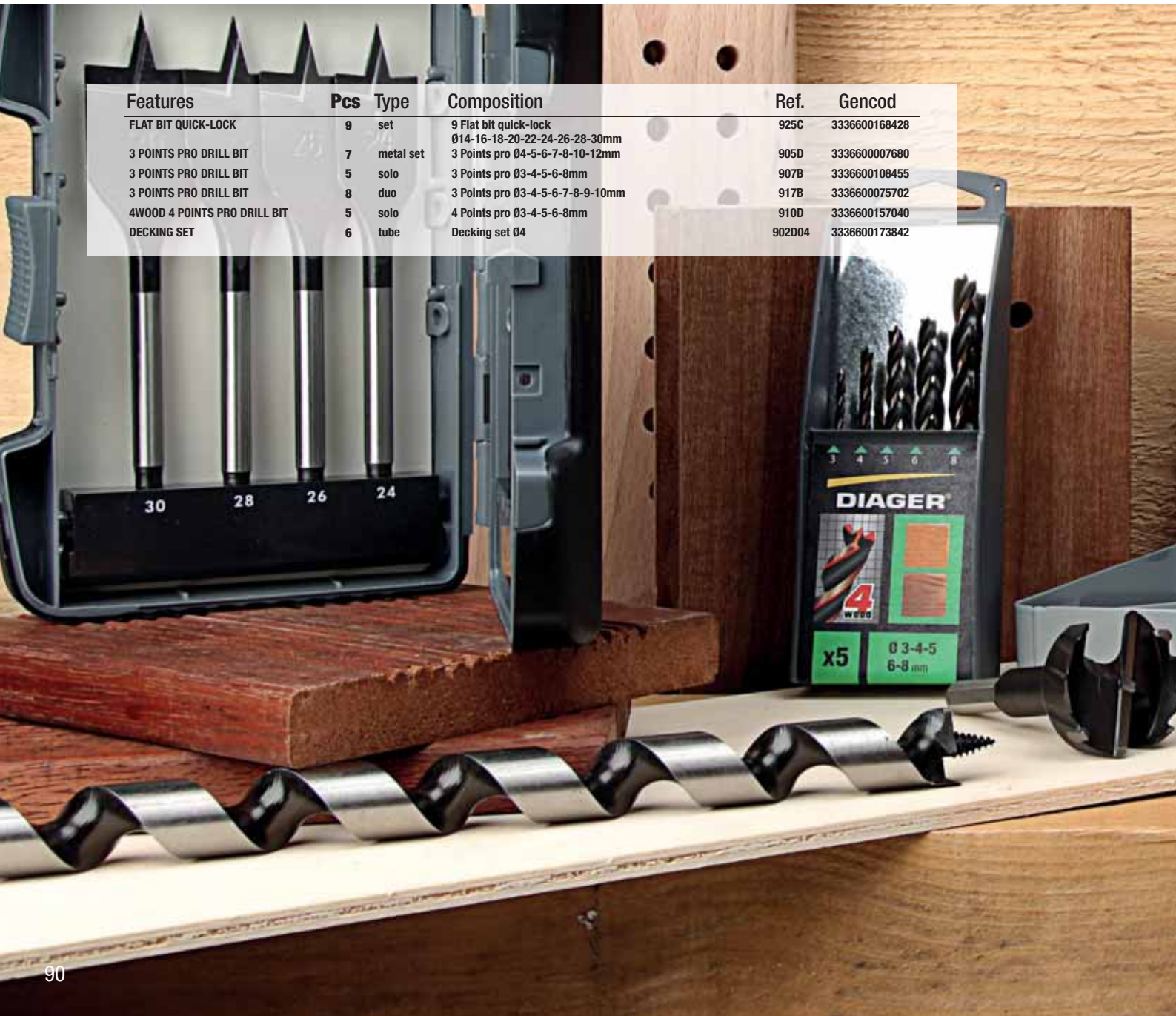

Features	Pcs	Type	Composition	Ref.	Gencod
FLAT BIT QUICK-LOCK	9	set	9 Flat bit quick-lock 014-16-18-20-22-24-26-28-30mm	925C	3336600168428
3 POINTS PRO DRILL BIT	7	metal set	3 Points pro 04-5-6-7-8-10-12mm	905D	3336600007680
3 POINTS PRO DRILL BIT	5	solo	3 Points pro 03-4-5-6-8mm	907B	3336600108455
3 POINTS PRO DRILL BIT	8	duo	3 Points pro 03-4-5-6-7-8-9-10mm	917B	3336600075702
4WOOD 4 POINTS PRO DRILL BIT	5	solo	4 Points pro 03-4-5-6-8mm	910D	3336600157040
DECKING SET	6	tube	Decking set 04	902D04	3336600173842



913C



943C



940D



Features	Pcs	Type	Composition	Ref.	Gencod
AUGER BIT PRO HEX	5	case	Auger bit hex L460mm Ø12-14-16-18-20mm	913C	3336600157583
AUGER BIT PRO SDS PLUS	5	case	Auger bit pro compatible SDS-plus L400mm Ø12-14-16-18-20mm	943C	3336600157590
WOODMAX	5	case	Wodmax Ø15-20-25-30-35mm	940D	3336600146839



**BLUE
SHOCK**

*New screw bit
made in DIAGER*

Longer lifetime !

Manufacturer

Over 35 years' know-how to produce quality bits and bit holders.

Cold heading

The bit is given its shape by means of cold heading. That manufacturing process gives the bits high precision, greater mechanical strength and a very clean surface condition..



Precision

The accuracy of the bit geometry will allow to fit perfectly in the screw. The restitution of the force transmitted by the machine will be ensured to 100%.

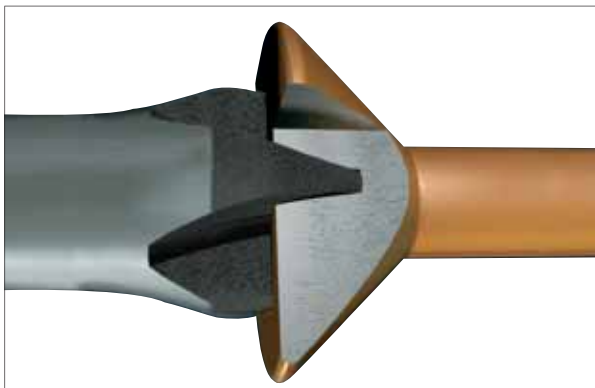

Cold forging process

This exclusive manufacturing process used by USH allows very effective transmission of tightening torque. Break resistance is approximately 30% higher than that of a conventional bit holder.

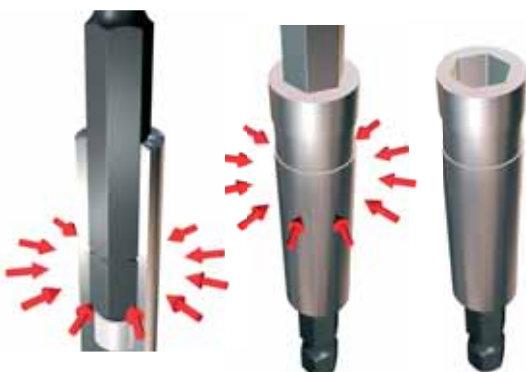

Bit holder

The manufacturing process associated with steels of high quality allows to obtain a resistance to the upper break of about 30% compared to the Doorsstandard tips.



Torsion Geometry

The torsion geometry Flex enables you to increase the torque.

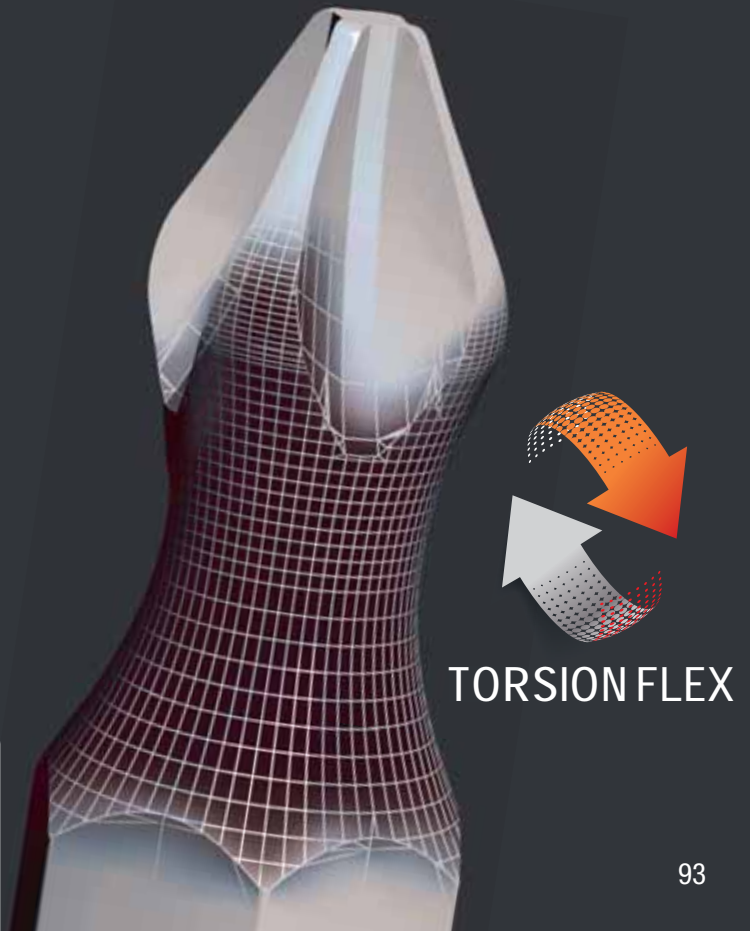

Ref.

U610PH
U612PZ
U613T



L30 DIN 3126 C6,3

Impact bit

Features

- Lifetime 12x longer than standard screwbits.
- BlueFit Precision : PH, PZ, TX perfectly fits screwheads and avoid slipping and destroying head geometry.
- BlueRing Reinforcement : a strong ring reinforces the head for an even longer resistance.
- BlueShape Anti-breakage : the flex zone is reinforced on each side for an even stronger link with the head and the attachment and avoid breakages.
- Shock absorber : the Blueshock screw bit offers a special design with elongated torsion zone, resisting to high torque and violent impacts . Its hardness suits the most powerfull machines.
- BlueGuide attachment : 30 mm length for an easy use with or without bitholder.

Hexa 1/4" DIN 3126 C 6,3 attachment

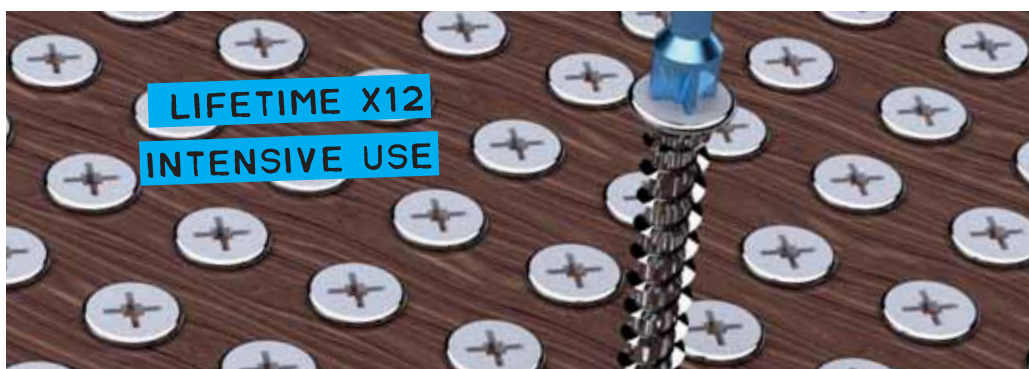

5 PIECES	Designation	Qt.	Lt	Ref.	Gencod	Qt.
	PHILIPS ⚡	5				
	PH2	5	30	U610PH2	3336600172043	1
	PH3	5	30	U610PH3	3336600172067	1
	POZIDRIV ⚡					
	PZ2	5	30	U612PZ2	3336600172074	1
	PZ3	5	30	U612PZ3	3336600172098	1
	TORX ⚡					
	T10	5	30	U613T10	3336600172104	1
	T15	5	30	U613T15	3336600172111	1
	T20	5	30	U613T20	3336600172128	1
	T25	5	30	U613T25	3336600172135	1
	T30	5	30	U613T30	3336600172142	1
T40	5	30	U613T40	3336600172159	1	

10 PIECES	Designation	Qt.	Lt	Ref.	Gencod	Qt.
	PHILIPS ⚡					
	PH2	10	30	U610PH210	3336600172050	1
	POZIDRIV ⚡					
	PZ2	10	30	U612PZ210	3336600172081	1

25 PIECES	Designation	Qt.	Lt	Ref.	Gencod	Qt.
	PHILIPS ⚡					
	PH2	25	30	U610PH225	3336600187634	1
	POZIDRIV ⚡					
	PZ1	25	30	U612PZ125	3336600187610	1
PZ2	25	30	U612PZ225	3336600187627	1	
	TORX ⚡					
	T20	25	30	U613T2025	3336600189836	1
	T25	25	30	U613T2525	3336600189843	1
T30	25	30	U613T3025	3336600189850	1	

ALL SETS
PAGES 106-107



U621B



Bit holder impact

Features

- Zone anti-choc Shock Absorber : the bit holder offers a studied and elongated torsion zone to withstand high torque and violent impact when used on a shock screwdriver for an unmatched service life.
- Blue rust proofing finish
- Magnetic to allow the manipulation of screws.

	Designation	Qt.	Lt	Ref.	Gencod	Qt.
	Bit holder Blue shock	1	60	U621B	3336600192379	1

Shock Absorber zone Shock Absorber

The Blueshock screw bit offers a special design with elongated torsion zone, resisting to high torque and violent impacts. Its hardness suits the most powerful machines.

BlueFit Precision

PH, PZ, TX perfectly fits screwheads and avoid slipping and destroying head geometry.



BlueRing Reinforcement

A strong ring reinforces the head for an even longer resistance.

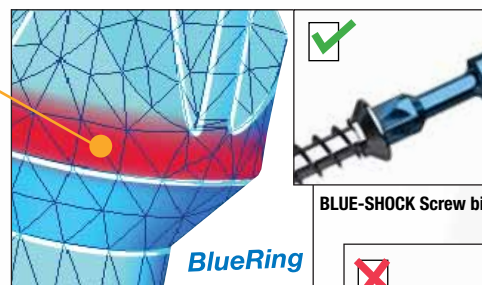

BLUE-SHOCK Screw bit



STANDARD Screw bit

BlueShape Anti-Breakage

The flex zone is reinforced on each side for an even stronger link with the head and the attachment and avoid breakages.

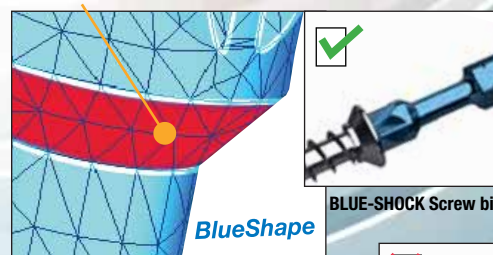

BLUE-SHOCK Screw bit

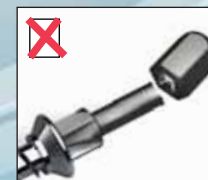
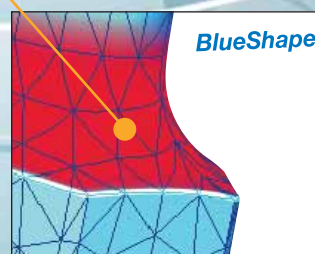

STANDARD Screw bit

BLUE SHOCK

SCREW BIT

Stainless steel bit

Ref.
U650

RUST PROOFING

PERFECT FOR OUTSIDE WORK

TO BE USE WITH STAINLESS STEEL SCREWS

Features

- Attachement C6,3 Din 3126.
- Stainless steel.
- Anti-rust.

Benefits

- Rust proofing.
- It is recomanded to use stainless steel bits with stainless steel screws.
- Suitable for PH, PZ, TX, PL head screw.

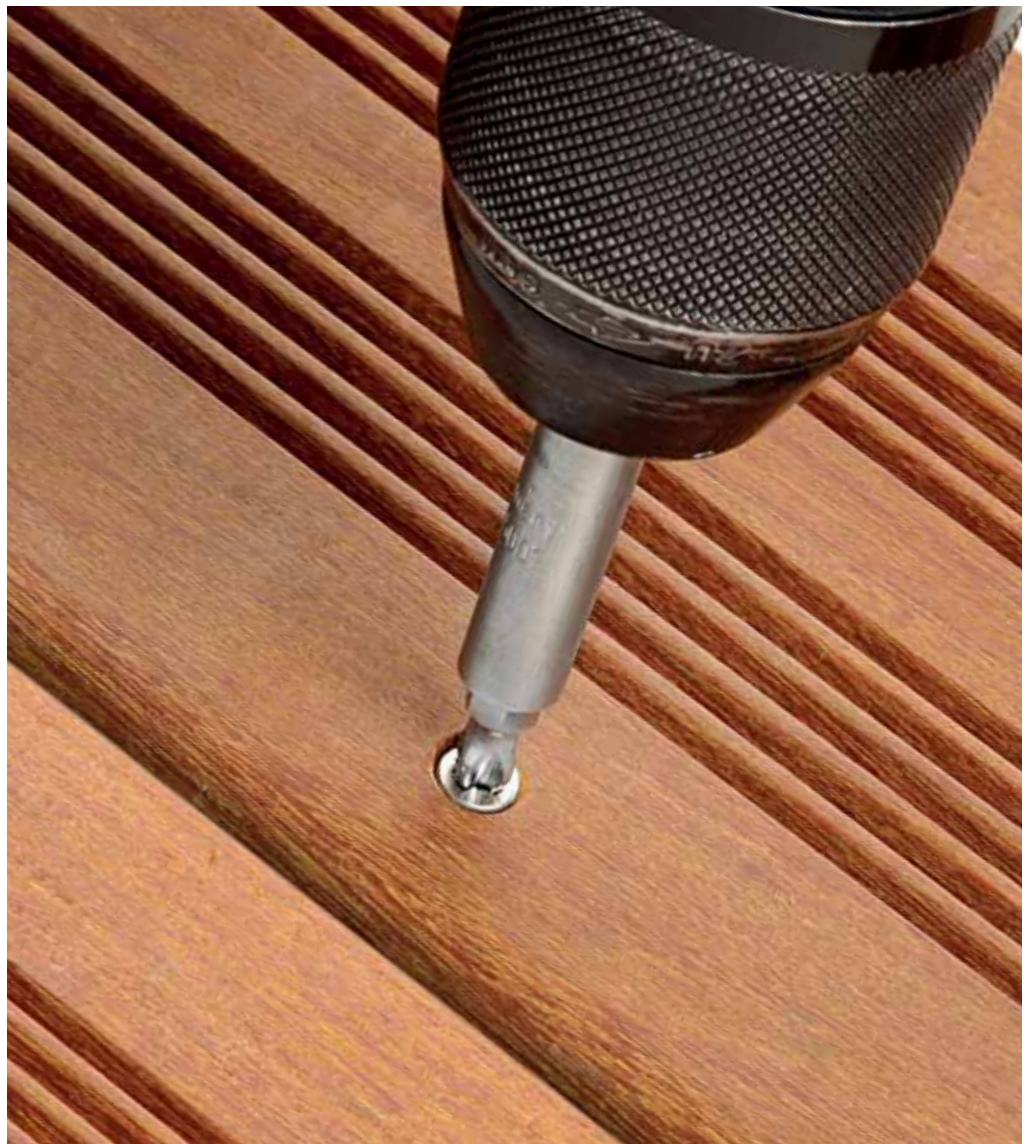

L25 DIN 3126 C 6.3



RUST PROOFING

5
PIECES



Designation	Qt.	Ref.	Gencod	Qt.
FLAT ⚡				
PL0,8x4	5	U650PL4	3336600190009	1
PL0,8x5	5	U650PL5	3336600190016	1
PL0,8x5,5	5	U650PL5,5	3336600190023	1
PL1,2x6,5	5	U650PL6,5	3336600190030	1
PHILIPS ⚡				
PH1	5	U650PH1	3336600189881	1
PH2	5	U650PH2	3336600189898	1
PH3	5	U650PH3	3336600189904	1

Designation	Qt.	Ref.	Gencod	Qt.
POZIDRIV ⚡				
PZ1	5	U650PZ1	3336600189911	1
PZ2	5	U650PZ2	3336600189928	1
PZ3	5	U650PZ3	3336600189935	1
TORX ⚡				
T10	5	U650T10	3336600189942	1
T15	5	U650T15	3336600189959	1
T20	5	U650T20	3336600189966	1
T25	5	U650T25	3336600189973	1
T30	5	U650T30	3336600189980	1
T40	5	U650T40	3336600190993	1

DiaTin bit

Ref.

U631PL
U630PH
U632PZ
U633T

Features

- The DiaTin coating is a combination of TiN coating with DLC (Diamond Like Carbon) coating on the parts exposed to friction in use.
- High hardness (3000 Vickers).
- Torsion geometry.
- Attachment DIN 3126 C 6,3 or E 6,3.
- Rust proof protection.

Benefits

- DLC coating improves wear resistance and lengthens the life of the bit.
- It also ensures perfect holding between bit and screw, thus keeping the bit from slipping and protecting screw heads.
- It reduces the force required for implementation.
- Higher torsion resistance.
- Greater lock attachment for optimum holding in the chuck.
- The torsion geometry combined with the DiaTIN coating increases the resistance to tightening torque.
- Fully compatible with PL, PH, PZ, TX type screws.

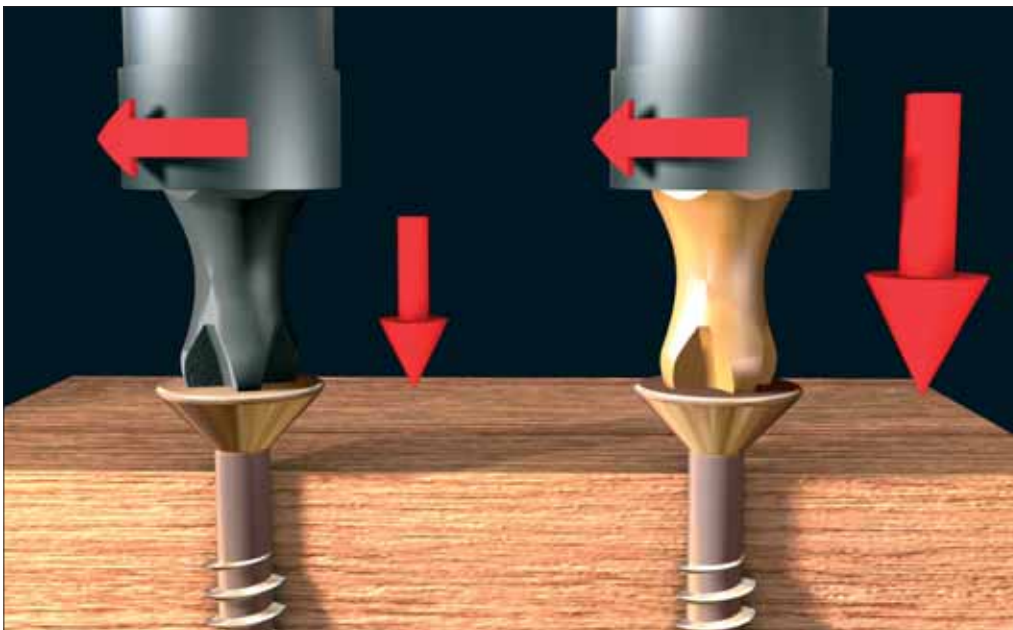

L25 DIN 3126 C6,3
L50 DIN 3126 E6,3

Designation	Qt.	Lt	Ref.	Gencod	Qt.
3 PIECES					
FLAT					
PL0,6x4,5	3	25	U631PL2	3336600181298	1
PL0,8x5,5	3	25	U631PL3	3336600181304	1
PL1,2x6,5	3	25	U631PL4	3336600181311	1
PHILIPS					
1	3	25	U630PH1	3336600181328	1
2	3	25	U630PH2	3336600181335	1
3	3	25	U630PH3	3336600181342	1
1	3	50	U630PH1L050	3336600181441	1
2	3	50	U630PH2L050	3336600181458	1
3	3	50	U630PH3L050	3336600181465	1
POZIDRIV					
1	3	25	U632PZ1	3336600181359	1
2	3	25	U632PZ2	3336600181366	1
3	3	25	U632PZ3	3336600181373	1
1	3	50	U632PZ1L050	3336600181472	1
2	3	50	U632PZ2L050	3336600181489	1
3	3	50	U632PZ3L050	3336600181496	1
TORX					
10	3	25	U633T10	3336600181380	1
15	3	25	U633T15	3336600181397	1
20	3	25	U633T20	3336600181403	1
25	3	25	U633T25	3336600181410	1
30	3	25	U633T30	3336600181427	1
40	3	25	U633T40	3336600181434	1
10	3	50	U633T10L050	3336600181502	1
15	3	50	U633T15L050	3336600181519	1
20	3	50	U633T20L050	3336600181526	1
25	3	50	U633T25L050	3336600181533	1
30	3	50	U633T30L050	3336600181540	1
40	3	50	U633T40L050	3336600181557	1



Plastic box
European hole

Designation	Qt.	Lt	Ref.	Gencod	Qt.
25 PIECES					
PHILIPS					
PH2	25	25	U630PH225	3336600187603	1
POZIDRIV					
PZ2	25	25	U632PZ225	3336600187597	1



Plastic box
European hole

SCREW BIT

Ref.

U641PL
U640PH
U642PZ
U643T



L25 DIN 3126 C6,3
L50 DIN 3126 E6,3

Torsion bit

Features

- Torsion geometry.
- Attachment DIN 3126 C 6,3 or E 6,3.
- Standard DIN hardness.
- Rust proof protection.

Benefits

- Bits for classic power drivers.
- Torsion geometry for higher strength against the tightening torque.
- PL, PH, PZ, TX perfectly compatible heads.

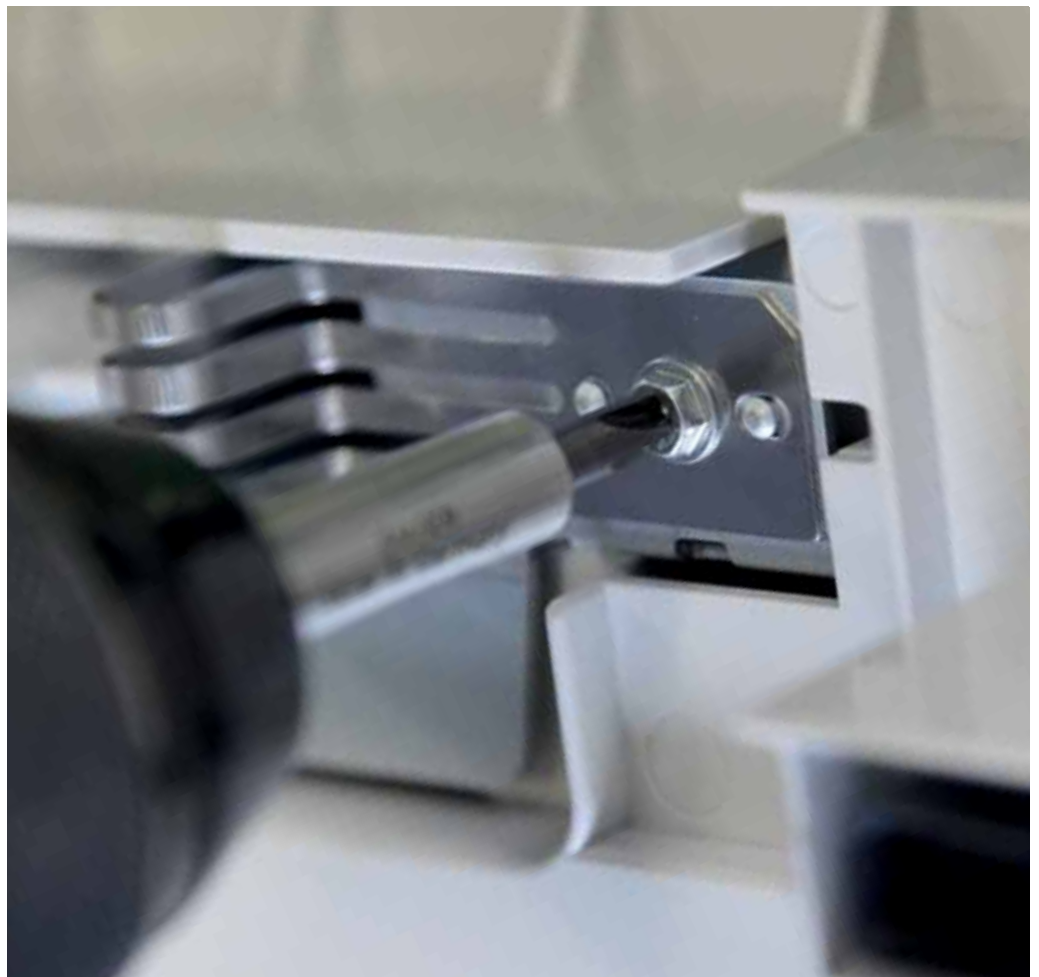

5
PIECES

Designation	Qt.	Lt	Ref.	Gencod	Qt.
FLAT ↻					
PL0,6x4,5	5	25	U641PL2	3336600171879	1
PL0,8x5,5	5	25	U641PL3	3336600171886	1
PL1,2x6,5	5	25	U641PL4	3336600171893	1
PL0,6x4,5	5	50	U641PL2L050	3336600181601	1
PL0,8x5,5	5	50	U641PL3L050	3336600181618	1
PL1,2x6,5	5	50	U641PL4L050	3336600181625	1
PHILIPS ↻					
PH0	5	25	U640PH0	3336600186187	1
PH1	5	25	U640PH1	3336600171909	1
PH2	5	25	U640PH2	3336600171916	1
PH3	5	25	U640PH3	3336600171930	1
PH1	5	50	U640PH1L050	3336600172166	1
PH2	5	50	U640PH2L050	3336600172173	1
PH3	5	50	U640PH3L050	3336600172197	1
POZIDRIV ↻					
PZ1	5	25	U642PZ1	3336600171947	1
PZ2	5	25	U642PZ2	3336600171954	1
PZ3	5	25	U642PZ3	3336600171978	1
PZ1	5	50	U642PZ1L050	3336600172203	1
PZ2	5	50	U642PZ2L050	3336600172210	1
PZ3	5	50	U642PZ3L050	3336600172234	1
TORX ↻					
T10	5	25	U643T10	3336600171985	1
T15	5	25	U643T15	3336600171992	1
T20	5	25	U643T20	3336600172005	1
T25	5	25	U643T25	3336600172012	1
T27	5	25	U643T27	3336600187504	1
T30	5	25	U643T30	3336600172029	1
T40	5	25	U643T40	3336600172036	1
T10	5	50	U643T10L050	3336600172241	1
T15	5	50	U643T15L050	3336600172258	1
T20	5	50	U643T20L050	3336600172265	1
T25	5	50	U643T25L050	3336600172272	1
T30	5	50	U643T30L050	3336600172289	1
T40	5	50	U643T40L050	3336600172296	1



ALL
SETS
PAGES 106-107



10
PIECES

Designation	Qt.	Lt	Ref.	Gencod	Qt.
PHILIPS ↻					
PH2	10	25	U640PH210	3336600171923	1
PH2	10	50	U640PH2L05010	3336600172180	1
POZIDRIV ↻					
PZ2	10	25	U642PZ210	3336600171961	1
PZ2	10	50	U642PZ2L05010	3336600172227	1



25
PIECES

Designation	Qt.	Lt	Ref.	Gencod	Qt.
PHILIPS ↻					
PH1	25	25	U640PH125	3336600176072	1
PH2	25	25	U640PH225	3336600189867	1
PH2	25	50	U640PH2L05025	3336600176157	1
PH3	25	25	U640PH325	3336600189874	1
PH3	25	50	U640PH3L05025	3336600191594	1
POZIDRIV ↻					
PZ1	25	25	U642PZ125	3336600176096	1
PZ2	25	25	U642PZ225	3336600187191	1
PZ3	25	25	U642PZ325	3336600176119	1
PZ2	25	50	U642PZ2L05025	3336600176164	1
TORX ↻					
T10	25	25	U643T1025	3336600191624	1
T15	25	25	U643T1525	3336600191631	1
T20	25	25	U643T2025	3336600176126	1
T25	25	25	U643T2525	3336600176133	1
T30	25	25	U643T3025	3336600176140	1
T40	25	25	U643T4025	3336600191648	1



Ref.

U620PH
U622PZ
U623T
U624TT
U625HEX



L50 DIN 3126 E6,3
L70 DIN 3126 E6,3
L90 DIN 3126 E6,3
L150 DIN 3126 E6,3

Reduced section quality bit

Features

- Attachment DIN 3126 C 6,3 or E 6,3.
- Rust proof protection.
- Standard DIN hardness.
- Small body section.
- Perfectly concentric.

Benefits

- Bits for conventional power screwdrivers.
- Perfectly suited to all DIN screws.
- Full transmission of tightening torque.
- Ideal for screwing in hard-to-reach areas.



3
PIECES



Plastic box
European hole

Or



Quality plastic pouch
European hole

Designation	qt.	Lt	Ref.	Gencod	Qt.
PHILIPS					
PH1	3	70	U620PH1L070	3336600181694	1
PH2	3	70	U620PH2L070	3336600181700	1
PH3	3	70	U620PH3L070	3336600181717	1
PH1	3	110	U640PH1L110	3336600172371	1
PH2	3	110	U640PH2L110	3336600172388	1
PH3	3	110	U640PH3L110	3336600172395	1
PH1	3	150	U620PH1L150	3336600181724	1
PH2	3	150	U620PH2L150	3336600181731	1
PH3	3	150	U620PH3L150	3336600181748	1
POZIDRIV					
PZ1	3	70	U622PZ1L070	3336600181755	1
PZ2	3	70	U622PZ2L070	3336600181762	1
PZ3	3	70	U622PZ3L070	3336600181779	1
PZ1	3	110	U642PZ1L110	3336600172401	1
PZ2	3	110	U642PZ2L110	3336600172418	1
PZ3	3	110	U642PZ3L110	3336600172425	1
PZ1	3	150	U622PZ1L150	3336600181786	1
PZ2	3	150	U622PZ2L150	3336600181793	1
PZ3	3	150	U622PZ3L150	3336600181809	1

Designation	qt.	Lt	Ref.	Gencod	Qt.
TORX					
T10	3	70	U623T10L070	3336600181816	1
T15	3	70	U623T15L070	3336600181823	1
T20	3	70	U623T20L070	3336600181830	1
T25	3	70	U623T25L070	3336600181847	1
T30	3	70	U623T30L070	3336600181854	1
T40	3	70	U623T40L070	3336600181861	1
T10	3	90	U623T10L090	3336600181878	1
T15	3	90	U623T15L090	3336600181885	1
T20	3	90	U623T20L090	3336600181892	1
T25	3	90	U623T25L090	3336600181908	1
T30	3	90	U623T30L090	3336600181915	1
T40	3	90	U623T40L090	3336600181922	1

5
PIECES



Plastic box
European hole

Designation	qt.	Lt	Ref.	Gencod	Qt.
PHILIPS					
PH0	5	50	U620PH0L050	3336600186132	1
TORX					
TT10	5	50	U624TT10L050	3336600181939	1
TT15	5	50	U624TT15L050	3336600181946	1
TT20	5	50	U624TT20L050	3336600181953	1
TT25	5	50	U624TT25L050	3336600181960	1
TT30	5	50	U624TT30L050	3336600181977	1
TT40	5	50	U624TT40L050	3336600181984	1

Designation	qt.	Lt	Ref.	Gencod	Qt.
HEXA					
HEX2	5	50	U625HEX02L050	3336600181991	1
HEX2,5	5	50	U625HEX02,5L050	3336600182004	1
HEX3	5	50	U625HEX03L050	3336600182011	1
HEX4	5	50	U625HEX04L050	3336600182028	1
HEX5	5	50	U625HEX05L050	3336600182035	1
HEX6	5	50	U625HEX06L050	3336600182042	1
HEX8	5	50	U625HEX08L050	3336600182059	1



Plastic box
European hole

20
PIECES

Designation	qt.	Lt	Ref.	Gencod	Qt.
PHILIPS					
PH2	20	110	U620PH2L11020	3336600178465	1

Quality bit

Features

- Attachment DIN 3126 C 6,3 or E 6,3.
- Rust proof protection.
- Standard DIN hardness.

Benefits

- Bits for conventional power screwdrivers.
- Perfectly suited to all DIN screws.
- Special bits.
- Full transmission of tightening torque.



Ref.

U624TT
U627SQ
U628SP
U625HEX



Made in Germany



L25 DIN 3126 C6,3

U626TTAP



Made in Germany



L25 DIN 3126 C6,3

5
PIECES

Designation	Qt.	Lt	Ref.	Gencod	Qt.
TORX TEMPER					
TT10	5	25	U624TT10	3336600178472	1
TT15	5	25	U624TT15	3336600178489	1
TT20	5	25	U624TT20	3336600178496	1
TT25	5	25	U624TT25	3336600178502	1
TT30	5	25	U624TT30	3336600178519	1
TT40	5	25	U624TT40	3336600178526	1
SQUARE					
SQ0	5	25	U627SQ0	3336600176171	1
SQ1	5	25	U627SQ1	3336600176188	1
SQ1	5	50	U627SQ1L050	3336600193970	1
SQ2	5	25	U627SQ2	3336600176195	1
SQ2	5	50	U627SQ2L050	3336600187498	1
SQ3	5	25	U627SQ3	3336600176201	1



Plastic box
European hole

Designation	Qt.	Lt	Ref.	Gencod	Qt.
HEXA					
HEX2	5	25	U625HEX02	3336600176218	1
HEX2,5	5	25	U625HEX02,5	3336600176225	1
HEX3	5	25	U625HEX03	3336600176232	1
HEX4	5	25	U625HEX04	3336600176249	1
HEX5	5	25	U625HEX05	3336600176256	1
HEX6	5	25	U625HEX06	3336600176263	1
HEX07	5	25	U625HEX07	3336600187320	1
HEX8	5	25	U625HEX08	3336600176270	1
SPANNER					
SP4	5	25	U628SP4	3336600178533	1
SP6	5	25	U628SP6	3336600178540	1
SP8	5	25	U628SP8	3336600178557	1
SP10	5	25	U628SP10	3336600178564	1

Quality Torx® TTAP® bit

Features

- Attachment DIN 3126 C 6,3 ou E 6,3.
- Rust proof protection.
- Standard DIN hardness.

Benefits

- Impression offers the most efficient drive system.
- Fingerprint of the tip penetrates more easily into the female socket of the screw.
- Impression allows perfect adhesion between the screw and the screwdriver bit. This prevents oscillation and shifting and allows one-handed operation without magnetic bit holders.
- No need to force on the screwdriver, which reduces fatigue.
- Fingerprint makes work with a visibly efficient tape feeder.



Plastic box
European hole

5
PIECES

Designation	Qt.	Lt	Ref.	Gencod	Qt.
TTAP10	5	25	U626TTAP10	3336600194267	1
TTAP15	5	25	U626TTAP15	3336600194274	1
TTAP20	5	25	U626TTAP20	3336600194281	1
TTAP30	5	25	U626TTAP30	3336600194298	1

new

Ref.
U637



DIN 3126 E6,3

Bit holder Big II

Features

- Attachment DIN 3126 E 6,3.
- For hexa bits 1/4" according to DIN 3126 C 6,3 and E 6,3.
- Automatic adjustable magnet.
- Double permanent magnets at the bottom and exit of the bit holder.
- Quick lock system to hold the bits.
- Cold forging process.

Benefits

- Effective holding of screws with powerful magnets.
- Automatic adjustment for optimum holding of the screw by direct contact with the magnet.
- Ideal for long screws.
- Ideal for horizontal and vertical work alike.
- Very high torsion resistance.



Plastic box
European hole

1 & 10
PIECES

Designation	Qt.	Lt	Ref.	Gencod	Qt.
Bit holder BIG II	1	68	U637	3336600181205	1
bit holder BIG II	10	68	U63710	3336600189188	1

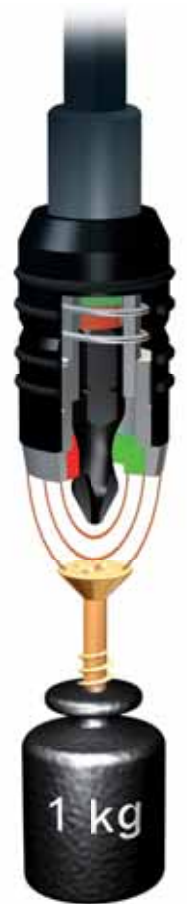

U634
U639



BIG

BIG Mini

DIN 3126 E6,3

Bit holder Big & Big mini

Features

- Attachment DIN 3126 E 6,3.
- For hexa bits 1/4" according to DIN 3126 C 6,3 et E 6,3.
- Double permanent magnets at the bottom and exit of the bit holder.
- Adjustable system.
- Cold forging process.

Benefits

- Depth adjustable - stop screw function.
- Big compatible with PH2, PH3, PZ2, PZ3, Torx 15 - 30.
- Big Mini compatible with PH1, PZ1 and Torx 10.
- Effective holding of screws with magnets.
- Ideal for long screws.
- Ideal for horizontal and vertical work alike.

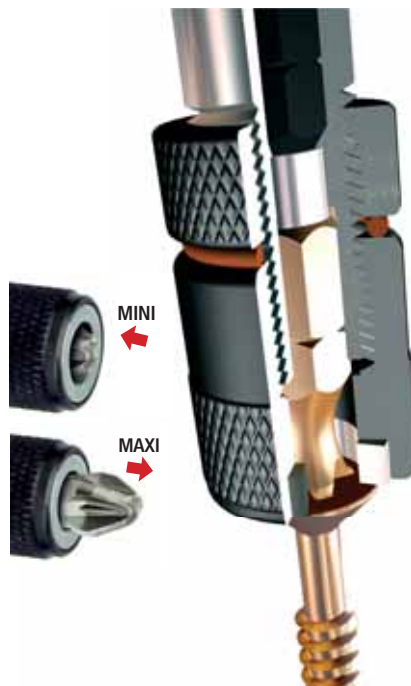

Plastic box
European hole

1 & 10
PIECES

Designation	Qt.	Lt	Ref.	Gencod	Qt.
Bit holder BiG	1	60	U634	3336600178212	1
Bit holder BiG	10	60	U63410	3336600189171	1
Bit holder BIG mini	1	60	U639	3336600181229	1

Bit holder Fox II

Ref.

U648
U638



DIN 3126 E6,3



Features

- Attachment DIN 3126 E 6,3. and compatible SDS+.
- For bits hexa 1/4" according to DIN 3126 C 6,3 and E 6,3.
- Permanent magnet.
- Cold forging process.

Benefits

- Quick ejection.
- Very high torsion resistance.
- Quick and easy manipulation with just one hand.
- Magnetic for handling the screws.



Plastic box
European hole

Designation	Qt.	Lt	Ref.	Gencod	Qt.
Bit holder Fox II	1	60	U648	3336600173156	1
Bit holder Fox II SDS-Plus	1	80	U638	3336600181212	1

Bit holder Standard

U626
U628
U629
U635



DIN 3126 E6,3



Features

- Attachment DIN 3126 E 6,3. and compatible SDS+.
- For hexa bits 1/4" according to DIN 3126 C 6,3 and E 6,3.
- Permanent magnet.
- Bit holding ring (sauf U628).
- Cold forging process.

Benefits

- Magnetic for handling the screws.
- Ideal for hard-to-reach areas, particularly with longer lengths (up to 250mm).



Quality plastic pouch
European hole

Plastic box
European hole

Designation	NEW	Qt.	Lt	Ref.	Gencod	Qt.	Pack
Bit holder Standard Quick-Lock		1	51	U626	3336600189119	1	R
Bit holder Standard		1	58	U628	3336600146792	1	R
Bit holder Standard		10	58	U62810	3336600189164	1	R
Bit holder Standard		1	74	U629L074	3336600181243	1	R
Bit holder Standard		1	100	U629L100	3336600181250	1	D
Bit holder Standard		1	150	U629L150	3336600181267	1	D
Bit holder Standard		1	200	U629L200	3336600181274	1	D
Bit holder Standard		1	250	U629L250	3336600181281	1	D
Bit holder SDS-Plus		1	78	U635	3336600178229	1	R

Bit Holder Shorty

U633



1/4" E6,3



Features

- Attachment DIN 3126 E 6,3.
- Standard socket holder male square 1/4.

Benefits

- Its reduced length fits entirely in the chuck and makes it possible to use the power screwdriver/drill in tight spaces.
- Magnetic for handling the screws.



Plastic box
European hole

Designation	Qt.	Lt	Ref.	Gencod	Qt.
Bit holder Shorty	1	35	U633	3336600181236	1



Ref.

637

DIN 3126 E6,3

90° angle driver

Features

- Attachement DIN 3126 E6,3
- Suitable for bits or drills 1/4" according to DIN 3126 C6,3 and E6,3
- 90° angle
- Handle can be moved by 30° step
- 2 ball bearing
- Torsion resistance up to 62 Nm
- RPM max 2000
- Size 138x50x28

Benefits

- Very usefull to drill in small space
- High quality and intensive use
- Can be use with cordless machine

qt.	Ref.	Gencod	UC
1	637	3336600187580	1



Twistpack

644



Flexible shaft bitholder handle

FLEXIBLE

Features

- Attachement E6,3 DIN 3126
- For bits 1/4" according to DIN 3126 C6,3 and E6,3
- Total lenght 270 mm
- Magnetics bit holder
- Ergonomic handle

Benefits

- Flexible shaft allows bending in any direction

qt.	Ref.	Gencod	UC
1	644	3336600187511	1



Plastic clip
European hole

646



Magnetic and telescopic bitholder handle

LENGTH EXPANDABLE

Features

- Attachement E6,3 DIN 3126
- For bits 1/4" according to DIN 3126 C6,3 and E6,3
- Ratchet function
- Ergonomic handle with 8 bits

Benefits

- Clockwise and anti clockwise rotation
- Adjustable lenght from 192 to 267 mm
- 8 bits PH1, PH2, PZ1, PZ2, T15, T20, T25, T30.

qt.	Ref.	Gencod	UC
1	646	3336600189096	1



Blister

645



Quick lock bitholder handle

Features

- Attachement E6,3 DIN 3126
- For bits 1/4" according to DIN 3126 C6,3 and E6,3
- Magnetic bits holder
- Ergonomic handle

Benefits

- Ergonomic 2 components handle allow a better torque

qt.	Ref.	Gencod	UC
1	645	3336600190047	1



Plastic clip
European hole

Surface protection socket

Features

- Attachment DIN 3126 E 6,3.
- For hex head screw.
- Mechanical screw holding system (ball/spring).

Benefits

- Specially adapted for screws used for fastening fronts or sandwich panels and self-drilling screws.
- The system that holds the screw head in the socket is specially designed for working with painted or plastic finishes.



Designation	Qt.	Lt	Ref.	Gencod	Qt.
S07	1	50	U601S07	3336600181632	1
S08	1	50	U601S08	3336600181649	1
S10	1	50	U601S10	3336600181656	1
S1/4 (6.35 mm)	1	50	U601S1/4	3336600181663	1
S5/16 (8 mm)	1	50	U601S5/16	3336600181670	1
S3/8 (9.5mm)	1	50	U601S3/8	3336600181687	1



ALL SETS PAGES 106-107

x7

U601

Ref. U601



DIN 3126 E6.3

Pro magnetic socket

Features

- Attachment DIN 3126 E 6,3.
- For hex head screw.
- Permanent magnet.

Applications

- Powerful magnet for holding screws.

ALL SETS PAGES 106-107

x7



U602

Designation	Qt.	Lt	Ref.	Gencod	Qt.
L 50					
S05.5	1	50	U600S05.5	3336600187276	1
S06	1	50	U600S06	3336600173118	1
S07	1	50	U600S07	3336600172319	1
S08	1	50	U600S08	3336600172326	1
S09	1	50	U600S09	3336600190276	1
S10	1	50	U600S10	3336600172340	1
S12	1	50	U600S12	3336600172357	1
S13	1	50	U600S13	3336600172364	1
S1/4	1	50	U600S1/4	3336600172302	1
S5/16	1	50	U600S5/16	3336600190276	1
S3/8	1	50	U600S3/8	3336600192386	1
L 65					
S05	1	65	U603S05	3336600187368	1
S05.5	1	65	U603S05.5	3336600187375	1
S06	1	65	U603S06	3336600187382	1
S07	1	65	U603S07	3336600187399	1
S08	1	65	U603S08	3336600187283	1
S10	1	65	U603S10	3336600187290	1
S12	1	65	U603S12	3336600190283	1
S13	1	65	U603S13	3336600187313	1

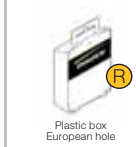

U600 U603



DIN 3126 E6.3

Adapter

Features

- Standard 1/4 square socket holder.
- Quick lock attachment for optimum holding in the chuck.



Designation	Qt.	Lt	Ref.	Gencod	Qt.
Socket holder	1	50	U636	3336600178236	1

U636



DIN 3126 E6.3

Stopvis



Designation	Qt.	Lt	Ref.	Gencod	Qt.
2 Stopvis PH2	2	25	627PH2	3336600146778	1
2 Stopvis PZ2	2	25	627PZ2	3336600146785	1

627



DIN 3126 C6.3

SCREW BIT



Made in Germany



U642C



U642D



U643C



U649C



U641D



U640D



U641C



U645C

Features

Pcs

Composition

Ref.

Gencod

SET SCREW BITS TORSION TX	7	TX10-15-20-25-30-40 + bit holder	U642C	3336600179547
SET SCREW BITS TORSION PZ-PH-PL	12	PZ1-2 (2)-3/PH1-2 (2)-3/ TX15-20-25 + bit holder	U642D	3336600180642
SET SCREW BITS TORSION	31	PZ1(x2)-2(x3)-3-(x2)/PH1(x2)-2(x3)-3(x2)/PL4,5-5,5/TX10-15-20(x3)-25(x2)-30(x2)/HEX2-3-4-5-6 + bit holder	U643C	3336600179554
SET SCREW BITS TORSION	15	PZ 1-2(2)-3 PH 1-2(2)-3 TX 15-20-25-30 PL5,5-6,5 + 1 bit holder Quick Lock FOX II	U649C	3336600183001
SET SCREW BITS TORSION PZ-PH	7	PZ1-2-3/PH1-2-3 + bit holder	U641D	3336600179530
SET SCREW BITS TORSION	12	PZ1-2 (2)-3/PH1-2 (2)-3/ PL4,5-5,5-6,5 + bit holder	U640D	3336600179523
SET SCREW BITS TORSION	19	PZ1-2-3/PH1-2-3/TX10-15-20-25-30-40/HEX3-4-5/PL4,5-5,5-6,5 + bit holder Quick-lock FOX II	U641C	3336600176287
SET SCREW BITS TORSION	19	PH1-2(2)-3 PZ1-2(2)-3 TX10-15-20-25-30-40 SW3-4-5 + bit holder Quick Lock FOX II	U645C	3336600183445



U644C



U643D



U601



U602



U618C

Features	Pcs	Composition	Ref.	Gencod
SET SCREW BITS TORSION	45	PH 1-1-2-2-3-3/PZ 1-1-2-2-3-3/PL 0.5X3 - 0.6X4.5 - 0.8X5.5 - 1X5.5 - 1.2X6.5 - 1.6X8/HX 2.5-3-4-5-6-7/TX 10-15-20-25-30-40 10 sockets : 5-6-7-8-9-10-11-12-13-14 + 1 hand key + 1 bit holder Fox II + 1 hand screwdriver+ + 1 adaptater female 1/4" - square + 1 adaptater male 1/4" - square	U644C	3336600182073
SET SCREW BITS TORSION & SOCKETS	80	1 Bit holder magnétique FoX II + 1 tourne-vis avec 8 embouts (Ph1, Ph2, Pz1, Pz2, TorxT15, T20, T25,T30) 70 screw bits torsion "Industry" : SL 0.5x3.0-0.6x4.5-0.8x5.5(x2)-1.2x6.5-1.6x8.0/PH 0-1-2(x4)-3(x2)/ HEX 2.0-2.5-3.0-4.0-5.0-6.0-7.0-8.0/PZ 1-2(x4)-3(x2)/TW 1-2-3-4-5/TOS 5-6-8-10/SQ 0-1-2-3/Tx Ta 10-15-20-25-30-40/HEXTa 3.0-4.0-5.0-6.0/Spanner 4-6-8-10/Tx 05-06-07-08-09/Tx 10-15-20(x2)-25(x2)-27-30-40 SW 7-8(x2)-3/8-10(x2)-5/16	U643D	3336600182066
KIT SOCKETS POWER	7	SW 7-8(x2)-3/8-10(x2)-5/16	U601	3336600189102
KIT SOCKETS STANDARD MAGNETIC	7	HEX 1/4-7-8-3/8-10-12-13	U602	3336600187115
SET SCREW BITS BLUE SHOCK	7	PZ2-3 / T20-25-30-40 + 1 Bit holder 58mm	U618C	3336600190290



SCREW BITS MERCHANDISING

P.O.S ADVERTISING TO SPUR SALES

Modular counter display



MODULAR CONCEPT

A minimum of space for a
maximum of references



COUNTER P.O.S ADVERTISING CONCEPT

To promote the sets





PLV BIT HOLDERS

POS counter for bit holders
Range recommended or adapted according
your needs



0.5 M SCREW BITS DISPLAY

Rack Presentation
Color-segmented screwing range for each
family (Torsion, Impact, Diatin, Quality, Bit
Holders and Sockets).
Declinations on 1M Sales shelf



Designation	Ref.	Gencod
0.5M SALES SHELF	GOND500	3336609000071
PEDIMENT FOR 0.5M SALES SHELF	FR500	33366090005373
ADJUSTABLE RACK WITHOUT HOOKS 0.5M	M00158	33366090005793
DOUBLE HOOK	M00151	33366090004475
1M SALES SHELF	GOND1000	3336609000019
PEDIMENT FOR 1M SALES SHELF	FR1000	33366090005472
ADJUSTABLE RACK WITHOUT HOOKS 1M	M00150	3336609000088
DOUBLE HOOK	M00151	33366090004475
DISPLAY CASE 1M FOR SETS	M00157	33366090005274
1M STAY FOR 1M SALES SHELF	BAR1000	3336609000057
SHELF 1M	TAB1000500	3336609000163
P.O.S. ADVERTISING TO SPUR SALES (with 2 shelves)	C00085	33366090005397
HOOK FOR REF. C00085	C00087	33366090005670
DISPLAY FOR BITS HOLDER	U3016418	3336609421968
"BULK" DISPLAY FOR SCREW BITS	M00120	3336609001306



BULK DISPLAY

for screw bits



Ref.

650

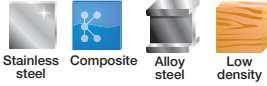

HSS-E
8% Co



Features

- HSS 8% cobalt Bi-metal.
- Teeth milled and side set.
- Progressive teeth.

Benefits

- Teeth MILLED: more resistance in the metal and enjoys a greater duration of life.
- Teeth SIDE SET: great power of cut. Ease of evacuation of the particles and avoids the lock.
- PROGRESSIVE teeth: versatility of cut. Reduction of vibration. Clean finish.

HSS 8% COBALT



TEETH MILLED

Milled teeth (compared to cut teeth) show more strength in metal and have a longer life.

TEETH SIDE SET

Setting directs one tooth to the left and another to the right. That is crucial to give the saw high cutting power, and it also makes the removal of cut particles easier, keeping the saw from blocking while sawing.

PROGRESSIVE TEETH

Set of seven teeth with well-defined shapes, reproduced over the whole perimeter of the saw. Variable-pitch teeth for cutting versatility with definite materials (metal, wood, plastics etc.), reducing vibrations and allowing a better finish.

TEETH 8% COBALT

The addition of cobalt improves resistance to heat. That alloy element makes it possible to withstand greater cutting forces and pierce hard materials such as stainless steel. The life is longer than that of a standard HSS saw.

see our video on
YouTube



Plastic clip
European hole

or

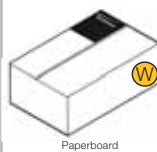

Paperboard

Ø	Lu	Lt	Ref.	Gencod	Qt.	Ø	Lu	Lt	Ref.	Gencod	Qt.
14	36	54	650D14	3336600159266	1	60	38	43,5	650D60	3336600159563	1
16	36	54	650D16	3336600159273	1	64	38	43,5	650D64	3336600159570	1
17	36	54	650D17	3336600159280	1	65	38	43,5	650D65	3336600159587	1
19	36	51	650D19	3336600159297	1	67	38	43,5	650D67	3336600159594	1
20	36	51	650D20	3336600159303	1	68	38	43,5	650D68	3336600159600	1
21	36	51	650D21	3336600159310	1	70	38	43,5	650D70	3336600159617	1
22	36	51	650D22	3336600159327	1	73	38	43,5	650D73	3336600159624	1
23	36	51	650D23	3336600159334	1	76	38	43,5	650D76	3336600159631	1
24	36	51	650D24	3336600159341	1	79	38	43,5	650D79	3336600159648	1
25	36	51	650D25	3336600159358	1	83	38	43,5	650D83	3336600159655	1
27	36	51	650D27	3336600159365	1	86	38	43,5	650D86	3336600159662	1
29	36	51	650D29	3336600159372	1	89	38	43,5	650D89	3336600159679	1
30	36	51	650D30	3336600159389	1	92	38	43,5	650D92	3336600159686	1
32	36	49	650D32	3336600159396	1	95	38	43,5	650D95	3336600159693	1
33	36	49	650D33	3336600159402	1	98	38	43,5	650D98	3336600159709	1
35	36	49	650D35	3336600159419	1	102	38	43,5	650D102	3336600159716	1
37	38	43,5	650D37	3336600159426	1	105	38	43,5	650D105	3336600159723	1
38	38	43,5	650D38	3336600159433	1	108	38	43,5	650D108	3336600159730	1
40	38	43,5	650D40	3336600159440	1	111	38	43,5	650D111	3336600159747	1
41	38	43,5	650D41	3336600159457	1	114	38	43,5	650D114	3336600159754	1
43	38	43,5	650D43	3336600159464	1	121	38	43,5	650D121	3336600159761	1
44	38	43,5	650D44	3336600159471	1	127	38	43,5	650D127	3336600159778	1
46	38	43,5	650D46	3336600159488	1	133	38	43,5	650D133	3336600159785	1
48	38	43,5	650D48	3336600159495	1	140	38	43,5	650D140	3336600159792	1
51	38	43,5	650D51	3336600159501	1	146	38	43,5	650D146	3336600159808	1
52	38	43,5	650D52	3336600159518	1	152	38	43,5	650D152	3336600159815	1
54	38	43,5	650D54	3336600159525	1	160	38	43,5	650D160	3336600159822	1
57	38	43,5	650D57	3336600159532	1	168	38	43,5	650D168	3336600159839	1
58	38	43,5	650D58	3336600159549	1	177	38	43,5	650D177	3336600159846	1
59	38	43,5	650D59	3336600159556	1	200	38	43,5	650D200	3336600159853	1
						210	38	43,5	650D210	3336600159860	1

HOLESAW SETS



Plumber
653C



Electrician I
654C



Electrician II
657C



General
655C



General Quick-Lock
656C



General Quick-Lock
651E

Features	Pcs	Composition	Ref.	Gencod
PLUMBER HOLESAW SET	9	Ø19-25-32-38-44-57-68 mm + 2 pilots hex 9.5 mm with pilot drill bit (Ø14-30 / Ø32-210 mm)	653C	3336600160316
ELECTRICIAN HOLESAW SET I	8	Ø22-35-51-57-68-76 mm + 2 pilots hex 9.5 mm with pilot drill bit (Ø14-30 / Ø32-210 mm)	654C	3336600160323
ELECTRICIAN HOLESAW SET II	8	Ø22-40-54-65-68-73 mm + 2 adaptaters Hex with pilot drill bit	657C	3336600173866
GENERAL HOLESAW SET	12	Ø19-22-25-32-35-38-44-57-68-76 mm + 2 pilots hexa 9.5 mm with pilot drill bit (Ø14-30 / Ø32-210 mm)	655C	3336600160330
GENERAL QUICK-LOCK HOLESAW SET	20	Ø19-22-25-32-38-44-57-68-76 mm + 1 pilot quick-lock hex 9.5 mm with pilot drill bit + 10 connectors	656C	3336600167001

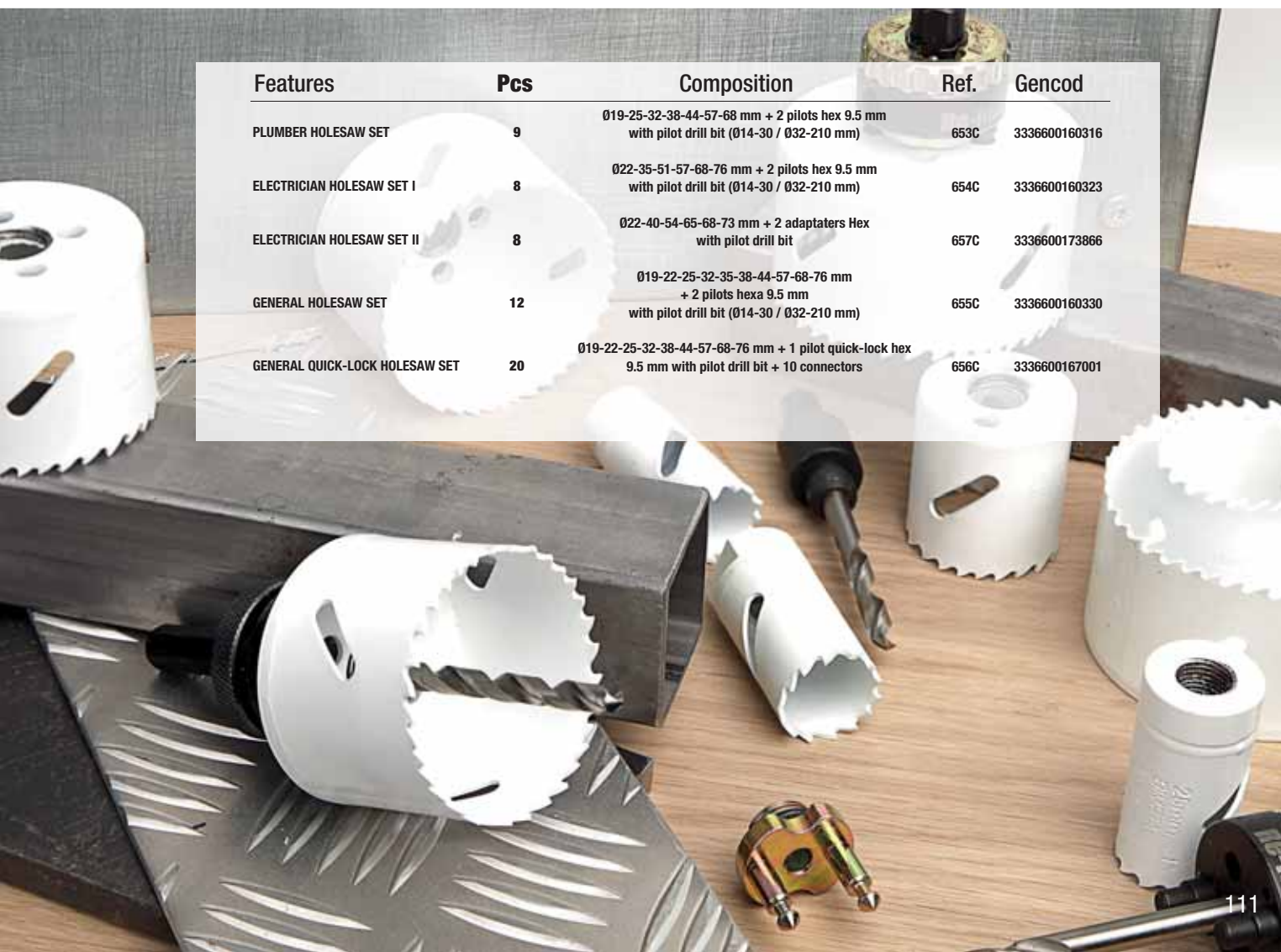



Ref.

651HEX01
651HEX03
651SDS01
651SDS02
651L

Standard system

HEX-shank or compatible SDS-plus



	Designation	Lt	Ref.	Gencod	Qt.	Pack
	Hex shank abrør 9,5mm (Ø14-30) with pilot drill bit	100	651HEX01	3336600159877	1	M
	Hex shank abrør 9,5 mm (Ø32-210) with pilot drill bit	127	651HEX03	3336600159891	1	M
	Hex shank abrør SDS-plus (Ø14-30) with pilot drill bit	120	651SDS01	3336600159914	1	M
	Hex shank abrør SDS-plus (Ø32-210) with pilot drill bit	131	651SDS02	3336600159921	1	M
	With pilot drill bit 83mm (x2)	83	651L083	3336600159938	1=2	H
	With pilot drill bit HSS for quick-lock	100	651L100	3336600160019	1=2	H
	With pilot drill bit 110mm (x2)	110	651L102	3336600159945	1=2	H
	Extension holesaw 300mm Hex 9,5 NEW	300	651RAHEXL300	3336600192584	1	H

DIY tube European hole
Twistpack incolore

651HEX01 ou 651SDS01

SLOT
Ø14-30

651L



DRILLING
Ø 14-30



651HEX03 ou 651SDS02

SLOT
Ø 32-210

651L



DRILLING
Ø 32-210



Quick-Lock system

HEXA

QUICK CHANGE



Ref.

- 652QLHEX
- 652QLFC
- 652QL
- 652QLDF
- 653QL
- 653QLDF
- 651L

Designation	Lt	Ref.	Gencod	Qt.	Pack
Pilot quick-lock hex 11mm (Ø14-210mm) + centring drill bit	127	652QLHEX	3336600159952	1	M
Connector quick-lock for saw (Ø14-30mm)	-	652QLFC	3336600159976	1=5	M
Connector quick-lock for saw (Ø32-210mm)	-	652QL	3336600159990	1=5	M
Connector quick-lock for saw (Ø32-210mm / Ø14-30)	-	652QLDF	3336600160002	1=5	M
Connector quick-lock (Ø14-30mm)	-	653QLFC	3336600190054	1=2	R
Connector quick- lock for saw (Ø32-210mm)	-	653QL	3336600190061	1=2	R
Connector quick-lock for saw (Ø32-210mm / Ø14-30)	-	653QLDF	3336600190078	1=2	R
Pilot hss drill bit 83mm (x2)	83	651L083	3336600159938	1=2	H
Pilot hss drill bit for quick-lock (x2)	100	651L100	3336600160019	1=2	H
Pilot hss drill bit 102mm (x2)	110	651L102	3336600159945	1=2	H

DIY tube
European hole

Twistpack incolore

Plastic box
European hole



SAWING MADE IN GERMANY



JIGSAW, RECIPROCATING SAW

Product characteristics

STAR teeth

Conically ground blade, teeth triply sharpened.

Benefits : Extreme fast, precise and clean cuts il all wood and plastics.



TWINCUT

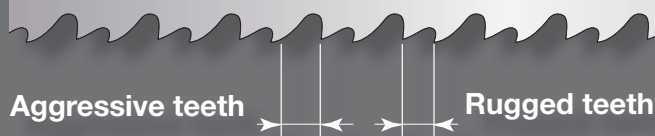

COMBO



COMBO teeth

Variable tooth pitch with two pitches. For e.g. 10/14 tpi, used in wood with metal residues.

TWINCUT teeth

Ideally applicable for metal sheets treatment, pipes and profiles with a thickness over 2mm and dismantling of wood with nails/screws.

The perfect twins : robust and aggressive and twin-cut toothing. There is a continuous change between a **very aggressive tooth** with a deep chic space and a **very robust tooth** with a flat chip space thus allowing a maximum speed and stability.

XLS technology : TWIN-CUT reciprocating saw blades are manufactured from a new powder metallurgical high-performance steel. The physical features of this XLS material make essentially smoother structures at the cutting edges of the teeth in the micro range.

With the XLS technology feature : tougher hardness treatment, better heat resistance, sharper longer.

CHOICE OF TEETH / APPLICATION

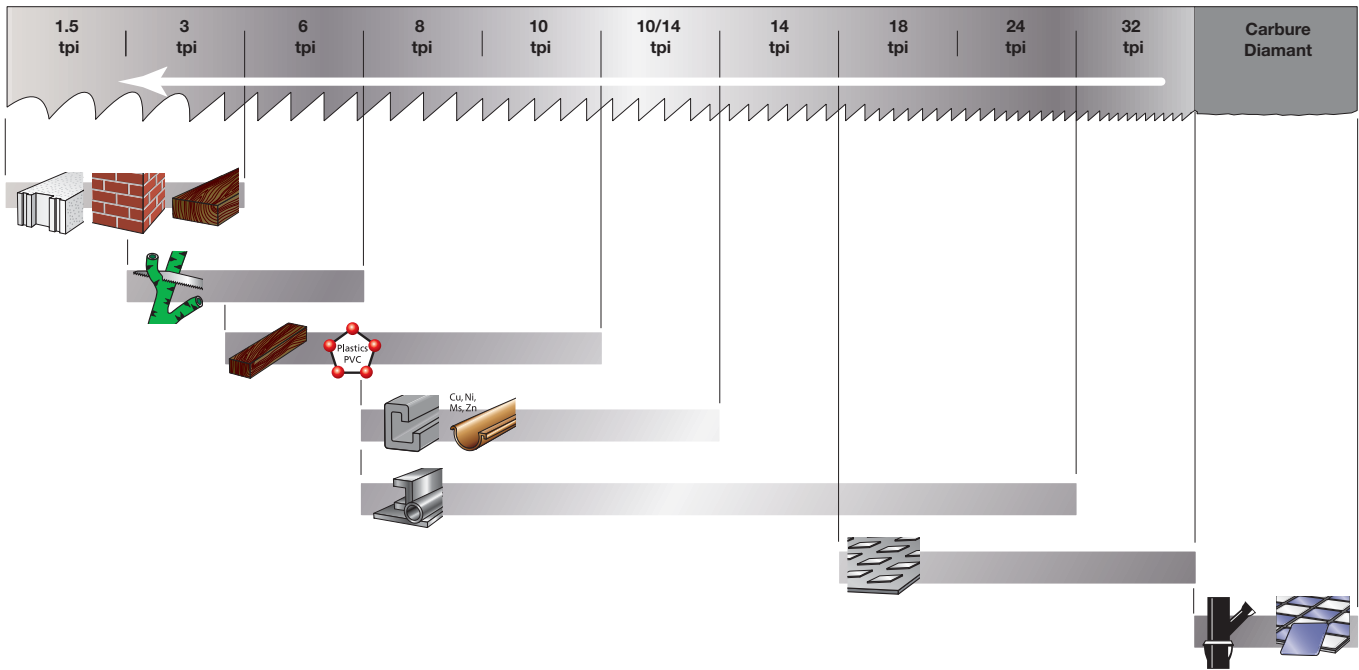

CHOICE OF BLADE MATERIAL / APPLICATION

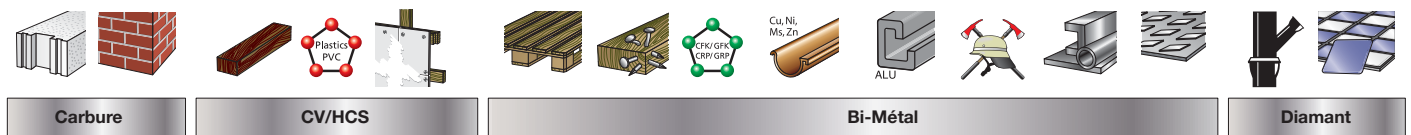

CHOICE OF SAW LENGTH

Blade length : material thickness + 50 mm

■ Always keep 2 or 3 teeth in the material.

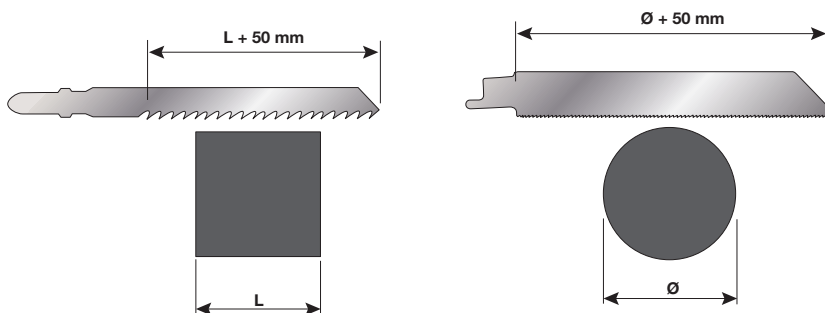

GLOSSARY PICTOGRAM

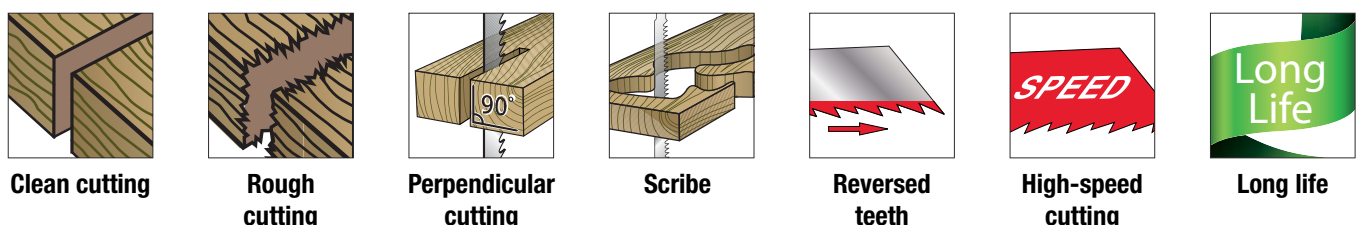

KIND OF TOOTHING

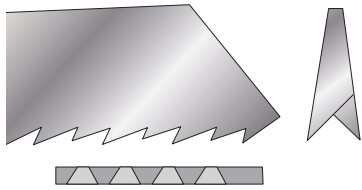

Grinded (or sharpened) teeth,
conically ground blade.

FAST CUT AND CLEAN

- The perfect aligned teeth allows a fast, precise and straight cut.
- The conical body of the blade leaves a gap between material and blade. Because of the gap, the chips get off and the blade cuts fast.

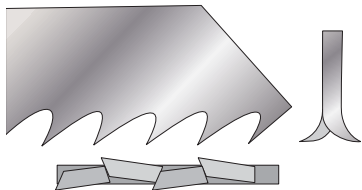

Grinded (or sharpened) and
side set teeth.

FAST AND ROUGH CUT

- The sharpened teeth cut the wood fibres that warranties a high speed cut especially adapted to wood cutting.

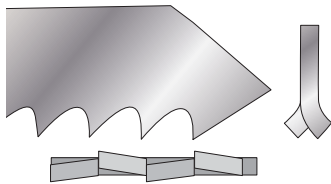

Milled and side set teeth.

FAST AND ROUGH CUT

- The milled and side set teeth cut roughly with high speed in wood, aluminium, non-ferrous metals and plastics.

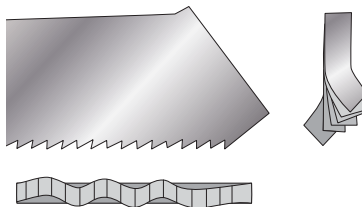

Milled and wavy set teeth.

CLEAN AND THIN CUT

- The milled and wavy set teeth keep contact with the material to cut, avoiding jerks and allowing thin and straight cut in thin material boards.

TEETH DIRECTION

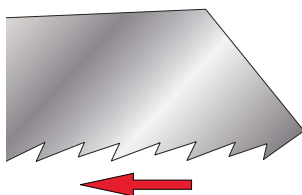

Regular tootinging
On Pull

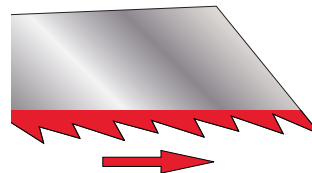

Reverse tootinging
On Push
Very clean and splinter-
proof surface cut

DOUBLE TEETH

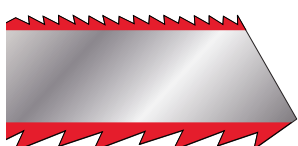

Ideal for curved cutting

see our
video on
YouTube

TYPES OF SAW



HSS

High quality high-speed steel. Allows high-speed cutting. Offers **high resistance to wear**. Designed for **hard materials**.

HCS CV

Steel alloy with carbon, chromium and vanadium. Chromium offers greater **corrosion resistance**. Vanadium increases the **heating capacity**. Designed for **soft materials**.

CARBURE

CARBIDE

There are three types of carbide saws: carbide-encrusted saws, saws with added carbide teeth or saws with added carbide strips. Carbide blades show **high performance and make it possible to cut hard and/or abrasive materials**.

DIAM

The DIAM blades are diamond gritted. These blades especially suit very **hard and/or abrasive materials** like composite materials.

Bi Metal FLEX

Bimetal refers to an item made of an assembly of two distinct types of steel, as opposed to alloys. The structure gives saw blades the best combination of cutting speed and durability, because the benefits of each type of steel are used where they are valuable: **the teeth are harder and offer high cutting performance, and the blade is more flexible, harder to break and stronger. The life of bimetal saws is twice to ten times that of HSS or HCS blades.**

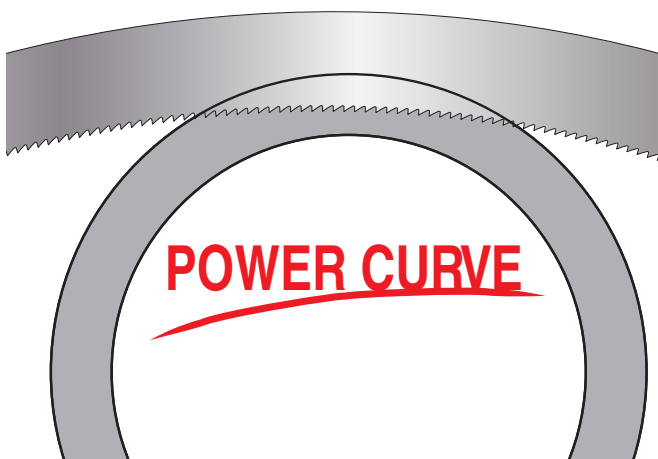

The latest design of a curved blade shape perfectly supports the natural orbital movement of the reciprocating saws thus allowing a high power transmission. Likewise the teeth are cutting into the work piece with the best angle possible based on the curved blade. They saw more effectively and thus achieve a better removal of the splints and a slower wearing down. You can perfectly utilize the length of the blade: there are up to additionally 10% of the teeth cutting into the work piece compared to a straight blade of the same length.

Benefits :

Faster working: cutting speed increased by up to 30%, more cuts: longer lifetime up to 25% compared to those blades with a straight shape.

BRANDS SAW BLADES COMPATIBILITY

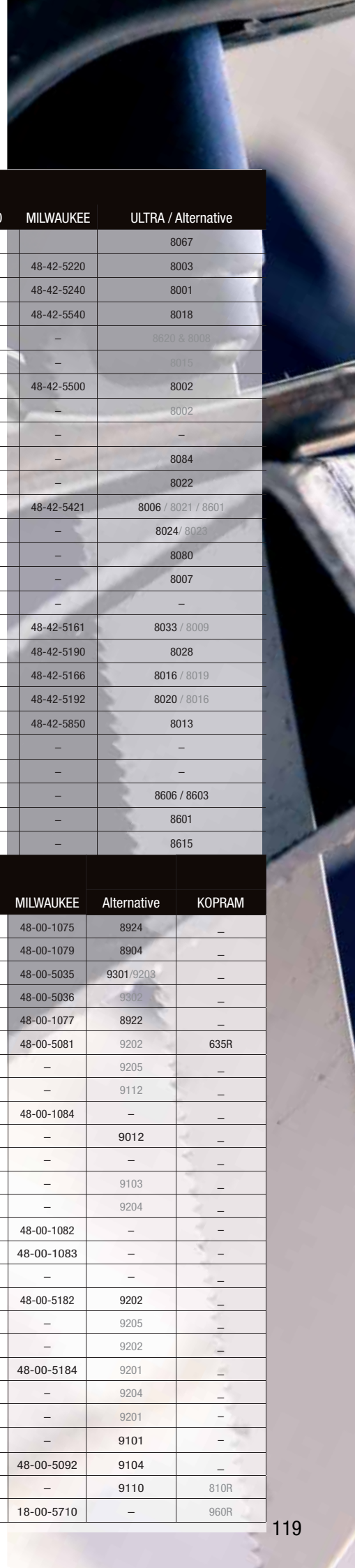

JIGSAW BLADES								
DIAGER	AEG	BOSCH / Alternative	FESTOOL	LENOX	MAKITA	METABO	MILWAUKEE	ULTRA / Alternative
L000W5	373083	T101AIF / T101AOF & T101BIF	-	-	P31566	23948	-	8067
L001W5	254071	T111C / T119B	-	410S	B13/A85656	23632	48-42-5220	8003
L002W5	254061	T101B	S75/2,5	450S	B11/A85634	23634	48-42-5240	8001
L003W5	346079	T101BR	-	450SR	B19/A85715	23650	48-42-5540	8018
L004W5	-	T101BF & T101BRF	HS75/3 Bi FC	-	-	-	-	8820 & 8008
L005W5	-	T119B0	-	-	-	-	-	8015
L006W5	274351	T101D	-	456S	B12/A85640	23635	48-42-5500	8002
L007W5	373080	T101DP	575/4FS	-	-	23655	-	8002
L008W5	-	T308B	-	-	-	-	-	-
L012W5	-	T234X / T102BF BIM	-	-	-	23675	-	8084
L009W5	399306	T301CD	-	-	B10/A85628	23654	-	8022
L010WL1005	213116	T144D / T144DF & T144DP & T244D	S75/4	406S	B16/A85684	23633	48-42-5421	8006 / 8021 / 8601
L010WL1325	311633	T344D / T344DF	S105/4	-	L2/P06454	23678	-	8024 / 8023
L010WL1805	354745	T744D	-	686S	A86315	23603	-	8080
L011W5	265312	T 244 D	-	-	P31572	-	-	8007
L012S5	-	T123XF / T123X & T345X & T345XF	-	-	-	-	-	-
L000M5	340011	T118AF / T118A & T218A	HS60/1,2BI	318S/324S	P47226	23971	48-42-5161	8033 / 8009
L001M5	340012	T118BF / T101A & T118B	HS60/2bi	314S	P47232	23973	48-42-5190	8028
L002M5	274654	T318AF	HS105/1,2BI	518S	P47204	23978	48-42-5166	8016 / 8019
L003M5	274653	T318BF	HS105/2bi	-	P47210	23979	48-42-5192	8020 / 8016
L004M5	340014	T127D & T227D	HS75/3bi	-	-	23974	48-42-5850	8013
L005M2	373393	T118AHM / T118EHM	-	-	P-05929	23662	-	-
LMIX001	-	T345XF	-	-	-	-	-	-
L100W5	-	-	-	-	-	-	-	8606 / 8603
L101W5	-	-	-	-	-	-	-	8601
L102M5	-	-	-	-	-	-	-	8615

RECIPROCATING SAW BLADES									
DIAGER	AEG	BOSCH / Alternative	DEWALT	LENOX	MAKITA	METABO	MILWAUKEE	Alternative	KOPRAM
L200WL1505	323800	S644D	DW4802	656R	P47086	37470	48-00-1075	8924	-
L200WL3005	323802	S1344D / S1111DF	DW4804	156R	P05016	31472	48-00-1079	8904	-
L201WL1505	354775	S611DF / S641HM & S611VF & S611DF	-	656R	P05088	-	48-00-5035	9301/9203	-
L201WL2255	354777	S1111DF	-	956R	-	-	48-00-5036	9302	-
L202WL2405	323803	S1531L / S1617K & S1111K	-	-	P47117	31488	48-00-1077	8922	-
L204SL1505	-	S922VF	DW4845	650R	P47014	31492	48-00-5081	9202	635R
L204SL2255	373288	S1122VF / S1120CF & S1122HF	-	-	-	31495	-	9205	-
L204SL2805	-	S1222VF	-	110R	-	31407	-	9112	-
L200SL3002	-	S 713 A	-	-	P80444	-	48-00-1084	-	-
L201SL2001	-	-	-	800RDG	-	-	-	9012	-
L202SL1152	-	S518EHM	-	-	-	31817	-	-	-
L203SL1505	-	-	-	-	-	-	-	9103	-
L203SL2255	-	S1234XF	-	-	-	-	-	9204	-
L205SL3001	373027	S1211K	-	-	-	-	48-00-1082	-	-
L205SL4001	373028	-	-	-	-	-	48-00-1083	-	-
L206SL3001	-	-	-	-	-	-	-	-	-
L200ML1505	354789	S922BF	DW4808	614R	P04911	31491	48-00-5182	9202	-
L200ML2005	361345	S1122BF	DW4809	814R	P04927	31494	-	9205	-
L201ML1505	-	-	-	-	-	-	-	9202	-
L202ML1505	354792	S922EF	DW4811	618R	P04880	31454	48-00-5184	9201	-
L202ML2005	354793	S1122EF	DW4821	818R	P04933	31493	-	9204	-
L203ML1505	-	-	-	-	-	-	-	9201	-
L204ML1505	354796	S922AF / S522AF	DW4813	624R	P04905	-	-	9101	-
L205ML1505	318127	S922HF	DW4806	610R	P46997	-	48-00-5092	9104	-
L205ML2805	-	-	-	-	P04983	-	-	9110	810R
L206ML3005	-	S1120CF	-	-	P46981	-	18-00-5710	-	960R

SAW BLADE SELECTION GUIDE

Materials

JigSaw Blades

Réf.	All types of wood	Laminated chipboards	Chipboard	Hard wood	Ply wood	Laminated coated, Parquet	Pallet	Windows	Wood with metal residues	Green wood	Plastics	Carbon-fibre reinforced products	Perspex	Varicor / corian	Stainless steel	Steelpipes, steelprofiles	Sheet metals	Non-ferrous metals	Aluminium	Frozen products	
L000W	Optimal	Possible	Possible	Possible	Possible	Possible															
L001W	Optimal	Possible	Possible	Possible	Possible	Possible															
L002W	Optimal	Possible	Possible	Possible	Possible	Possible															
L003W	Optimal	Possible	Possible	Possible	Possible	Possible															
L004W	Optimal	Possible	Possible	Possible	Possible	Possible															
L005W	Optimal	Possible	Possible	Possible	Possible	Possible															
L006W	Optimal	Possible	Possible	Possible	Possible	Possible															
L007W	Optimal	Possible	Possible	Possible	Possible	Possible															
L008W	Optimal	Possible	Possible	Possible	Possible	Possible															
L012W	Optimal	Possible	Possible	Possible	Possible	Possible															
L009W	Optimal	Possible	Possible	Possible	Possible	Possible															
L010W	Optimal	Possible	Possible	Possible	Possible	Possible															
L011W	Optimal	Possible	Possible	Possible	Possible	Possible															
L012S								Optimal													
L000M															Optimal	Optimal	Optimal	Optimal	Optimal	Optimal	
L001M															Optimal	Optimal	Optimal	Optimal	Optimal	Optimal	
L002M															Optimal	Optimal	Optimal	Optimal	Optimal	Optimal	
L003M															Optimal	Optimal	Optimal	Optimal	Optimal	Optimal	
L004M											Optimal		Optimal		Optimal	Optimal	Optimal	Optimal	Optimal	Optimal	
L005M											Optimal		Optimal		Optimal	Optimal	Optimal	Optimal	Optimal	Optimal	
L100W	Optimal	Possible	Possible	Possible	Possible	Possible															
L101W	Optimal	Possible	Possible	Possible	Possible	Possible															
L102M																					

Reciprocating Blades

L200W	Optimal	Possible	Possible	Possible	Possible	Possible															
L201W	Optimal	Possible	Possible	Possible	Possible	Possible															
L202W	Optimal	Possible	Possible	Possible	Possible	Possible				Optimal											
L200M															Optimal	Optimal	Optimal	Optimal	Optimal	Optimal	
L201M															Optimal	Optimal	Optimal	Optimal	Optimal	Optimal	
L202M															Optimal	Optimal	Optimal	Optimal	Optimal	Optimal	
L203M															Optimal	Optimal	Optimal	Optimal	Optimal	Optimal	
L204M															Optimal	Optimal	Optimal	Optimal	Optimal	Optimal	
L205M															Optimal	Optimal	Optimal	Optimal	Optimal	Optimal	
L206M	Optimal	Possible	Possible	Possible	Possible	Possible	Optimal								Optimal	Optimal	Optimal	Optimal	Optimal	Optimal	
L200S											Possible										
L201S																					
L202S												Optimal	Optimal	Optimal	Optimal	Optimal	Optimal	Optimal	Optimal	Optimal	
L203S									Optimal						Optimal	Optimal	Optimal	Optimal	Optimal	Optimal	
L204S								Optimal	Optimal						Optimal	Optimal	Optimal	Optimal	Optimal	Optimal	
L205S																					
L206S																					Optimal

Optimal Possible

JigSaw Blades

Materials

Benefits

Réf.	Cast iron	Sandwich panel	Tile	Plaster	Insulation Materials	Rubber	Leather	Ceramic, tile	Cement fibre	Clean cutting	Rough cutting	Curved cutting	Perpendicular cutting	High-speed cutting	Reversed teeth	Long life
L000W										✓						
L001W										✓						
L002W										✓						
L003W										✓						
L004W										✓						
L005W										✓		✓				
L006W										✓						
L007W										✓			✓			
L008W										✓				✓		
L012W										✓				✓		
L009W										✓						
L010W										✓	✓			✓		
L011W										✓		✓		✓		
L012S																✓
L000M																✓
L001M																✓
L002M		✓														✓
L003M		✓														✓
L004M		✓														✓
L005M		✓														✓
L100W										✓						
L101W										✓	✓					
L102M																✓

Reciprocating Blades

L200W				✓						✓	✓					
L201W										✓	✓		✓			✓
L202W										✓	✓					
L200M										✓	✓					✓
L201M										✓	✓			✓		✓
L202M										✓	✓			✓		✓
L203M										✓	✓			✓		✓
L204M		✓								✓	✓			✓		✓
L205M										✓	✓			✓		✓
L206M										✓	✓			✓		✓
L204S										✓	✓	✓				✓
L200S					✓	✓	✓			✓	✓					✓
L201S	✓		✓		✓	✓	✓			✓	✓					✓
L202S	✓		✓		✓	✓	✓			✓	✓					✓
L203S										✓	✓					✓
L205S										✓	✓			✓		✓
L206S			✓							✓	✓			✓		✓

Ref.
L000W

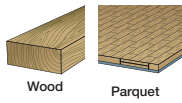

Features

- Conically ground blade, reverse and sharpened teeth. Clean and splinterfree surface cuts. Rolled floor, plywood, laminated chipboard (2,5-20mm).

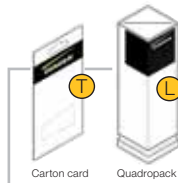
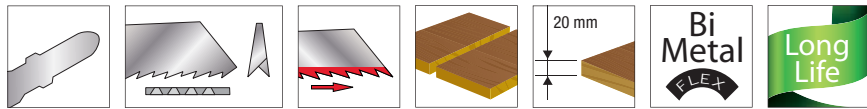

L	Lu	mm/tpi	Larg.	Ep.	Ref.	Gencod	Qt.	Pack
80	55	1.90/13	7.9	1.27	L000W5	3336600177710	5	T
80	55	1.90/13	7.9	1.27	L000W100	3336600185111	100	L

L001W

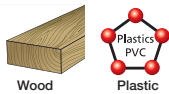

Features

- Milled and side set teeth. Soft wood, plastics (4-50mm).

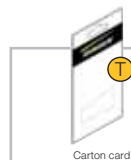
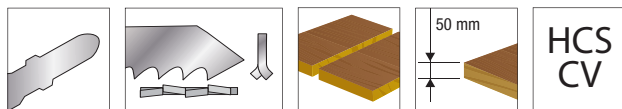

L	Lu	mm/tpi	Larg.	Ep.	Ref.	Gencod	Qt.
100	75	3/8.5	9.8	1.27	L001W5	3336600177727	5

L002W



CLEAN FINISH



Features

- Conically ground blade, sharpened teeth. Clean cut. All wood types, plastics (3-30mm).

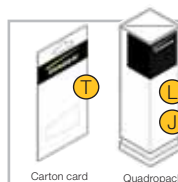
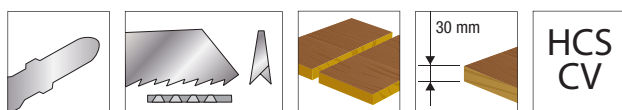

L	Lu	mm/tpi	Larg.	Ep.	Ref.	Gencod	Qt.	Pack
100	75	2.5/10	7.8	1.45	L002W5	3336600177734	5	T
100	75	2.5/10	7.8	1.45	L002W25	3336600184886	25	J
100	75	2.5/10	7.8	1.45	L002W100	3336600185135	100	L

CLEAN FINISH



Ref.

L003W

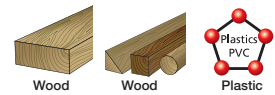

Features

- Conically ground blade, reverse and sharpened teeth. Clean and splinterfree surface cuts. All wood types, plastics (3-30mm).

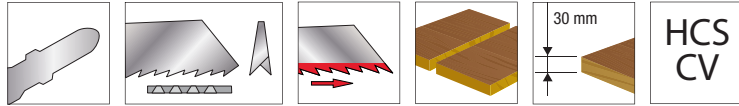

L	Lu	mm/tpi	Larg.	Ep.	Ref.	Gencod	Qt.
100	75	2.5/10	7.8	1.45	L003W5	3336600177741	5

Carton card

PLYWOOD AND LAMINATED CHIPBOARD



L004W

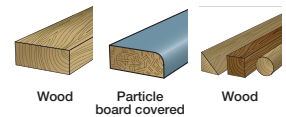

Features

- Conically ground blade, sharpened teeth. Fast and clean cut. Worktops, all types of wood, plastics (8-40mm).

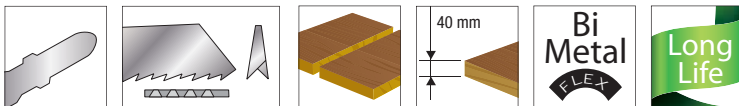

L	Lu	mm/tpi	Larg.	Ep.	Ref.	Gencod	Qt.
100	75	3/8.5	7.8	1.27	L004W5	3336600177758	5

Carton card

PERFECT TO SCRIBE



L005W

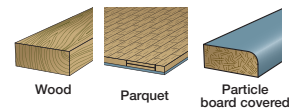

Features

- Conically ground blade, sharpened teeth and double toothing. Very clean and splinterfree surface cuts. Soft wood, Chipboard, fiberboard, laminate, parquett, plastic laminated board (2,5-35mm).

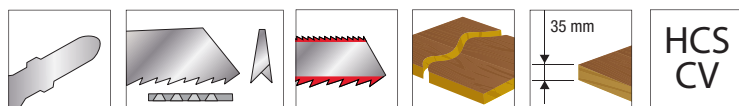

L	Lu	mm/tpi	Larg.	Ep.	Ref.	Gencod	Qt.
100	75	2.5/10	6.5	1.45	L005W5	3336600177765	5

Carton card

WOOD

JIGSAW BLADE

FAST CUT

Ref.

L006W



Features

- Conically ground blade, sharpened teeth. Fast and clean cut. All wood types, plastics (10-45mm).

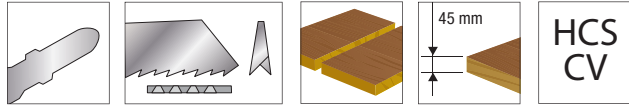

HCS
CV

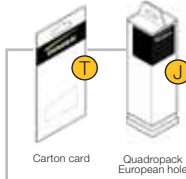

L	Lu	mm/tpi	Larg.	Ep.	Ref.	Gencod	Qt.	Pack
100	75	2.5/6.35	7.8	1.45	L006W5	3336600177772	5	T
100	75	2.5/6.35	7.8	1.45	L006W25	3336600184923	25	J

L007W



FAST AND CLEAN HARD WOOD



Feature

- Conically ground blade, sharpened teeth, special thick blade. Clean cut. Hard wood, soft wood, laminated chipboard, plastics (10-45mm).

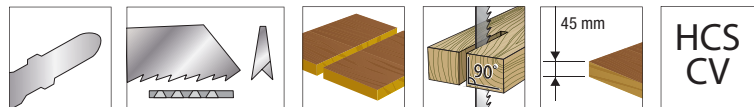

HCS
CV



L	Lu	mm/tpi	Larg.	Ep.	Ref.	Gencod	Qt.
100	75	4/6.35	7.8	1.68	L007W5	3336600177789	5

L008W

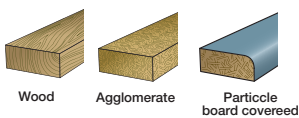

VERY FAST AND VERY CLEAN CUT
SPECIAL CHIPBOARD



Features

- Conically ground blade, reverse and tri-sharpened teeth. Very fast and very clean cut. Soft wood, chipboard, fiberboard, laminate, parquett, plastic laminated board (1,9-40mm).

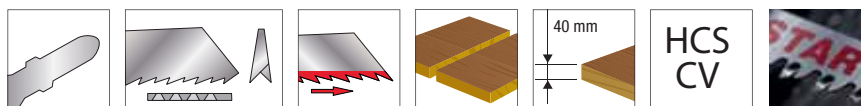

HCS
CV



L	Lu	mm/tpi	Larg.	Ep.	Ref.	Gencod	Qt.
117	91	1.90/13	10	1.45	L008W5	3336600177796	5

COMPOSITE MATERIALS AND PERSPEX



Features

- Conically ground blade, tri-sharpened teeth. Very fast and clean cut. All types of woods and plastic, Bangkirai, Varicor/Corian, Trespa (3-60mm).

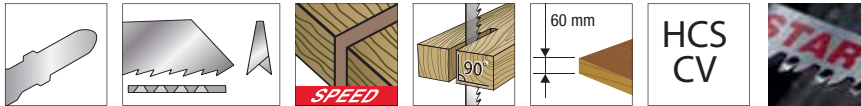

L	Lu	mm/tpi	Larg.	Ep.	Ref.	Gencod	Qt.
117	91	2.50/10	10	1.45	L012W5	3336600178243	5

Carton card

Ref.

L012W

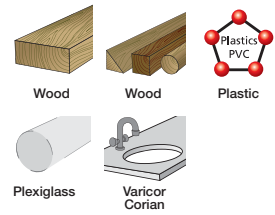

CLEAN CUT



Features

- Conically ground blade, sharpened teeth, special long saw blade. Clean cut. All types of wood (8-65mm).

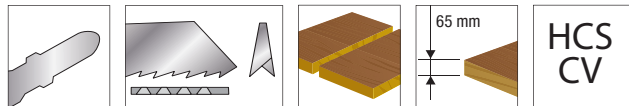

L	Lu	mm/tpi	Larg.	Ep.	Ref.	Gencod	Qt.	Pack
132	105	3/8.5	7.8	1.45	L009W5	3336600177802	5	T
132	105	3/8.5	7.8	1.45	L009W25	3336600184954	25	J

Carton card Quadrapack European hole

L009W



FAST



Features

- Sharpened and side set teeth. Fast and rough cut. All types of wood (5-50/80/120mm).



L	Lu	mm/tpi	Larg.	Ep.	Ref.	Gencod	Qt.	Pack
100	75	4/6.35	7.8	1.27	L010WL1005	3336600177819	5	T
100	75	4/6.35	7.8	1.27	L010WL10025	3336600184961	25	J
100	75	4/6.35	7.8	1.27	L010WL100100	3336600185210	100	L
132	105	4/6.35	7.8	1.27	L010WL1325	3336600177826	5	T
180	155	4/6.35	7.8	1.27	L010WL1805	3336600177833	5	T

Carton card Quadrapack

L010W



WOOD

JIGSAW BLADE

Ref.
L011W



Features

- Sharpened and side set teeth, double toothing. Fast and rough cut. All types of wood (5-50mm).

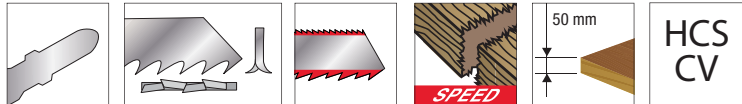

L	Lu	mm/tpi	Larg.	Ep.	Ref.	Gencod	Qt.
100	75	4/6.35	6.5	1.27	L011W5	3336600177840	5

Carton card

L100W



CLEAN FINISH



Features

- Conically ground blade, sharpened teeth. Clean cut. All wood types, plastics (3-30mm).

Compatible
Black & Decker

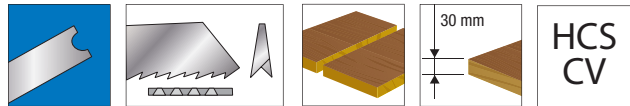

L	Lu	mm/tpi	Larg.	Ep.	Ref.	Gencod	Qt.
100	75	2.5/10	7.8	1.27	L100W5	3336600177925	5

Carton card

L101W



Features

- Sharpened and side set teeth. Fast and rough cut. All types of wood (5-50mm).

Compatible
Black & Decker

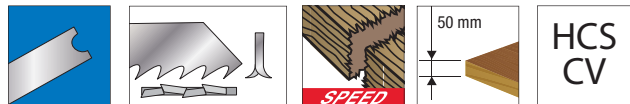

L	Lu	mm/tpi	Larg.	Ep.	Ref.	Gencod	Qt.
100	75	4/6.35	7.8	1.27	L101W5	3336600177932	5

Carton card

SPECIAL NAILS



Ref.
L012S

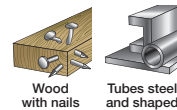

Features

- Milled and side set teeth. Twincut toothing. Flexible blade. Wood with nails/screws (<50mm), metal (2,5-10mm).

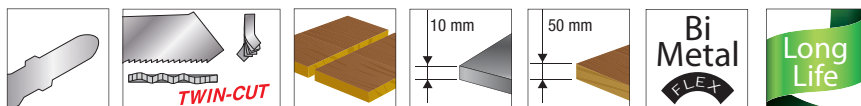

L	Lu	mm/tpi	Larg.	Ep.	Ref.	Gencod	Qt.
116	91	1.3/13 2.0/19	9.8	1	L012S5	3336600177956	5



Carton card

5 blades set

LMIX001

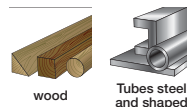
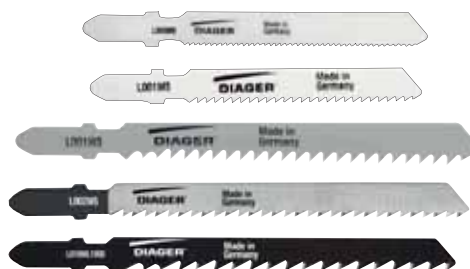
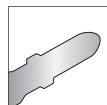

Composition	Ref.	Gencod	Qt.
L000M-L001M L010W-L001W L002W	LMIX001	3336600177918	5

TIPS

- ▣ The shape and pitch of the teeth define the type of cutting.
- ▣ It is important to always keep two or three teeth in the material to cut; otherwise, there is major risk of breaking the blade.
- ▣ Never remove the blade from the cut material while the blade is in motion. First stop the machine, wait for the blade to come to a halt and then remove it.
- ▣ Saw blades with a small pitch should be used for fine materials and blades with a large pitch should be used for thick materials.
- ▣ To increase the life of the saw blade, use cooling liquid: cutting oil for steel or metal, kerosene for aluminium and water for plastic and fibreglass.

EXTRA THIN STEEL SHEETS

Ref.
L000M

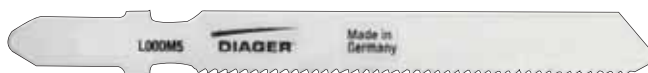
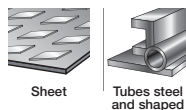

Features

- Milled and wavy set teeth. Flexible blade. Steel sheets, steelprofiles, stainless steel (1,2-2mm).

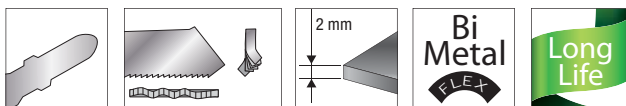

	L	Lu	mm/tpi	Larg.	Ep.	Ref.	Gencod	Qt.	Pack
	76.5	55	1.2/21	7.8	1	L000M5	3336600177857	5	T
	76.5	55	1.2/21	7.8	1	L000M25	3336600185036	25	J

L001M



THIN STEEL PROFILES



Features

- Milled and wavy set teeth. Flexible blade. Steel sheets, steelprofiles, stainless steel, non-ferrous metal, aluminium (2,5-6mm).

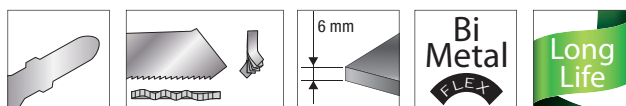

	L	Lu	mm/tpi	Larg.	Ep.	Ref.	Gencod	Qt.	Pack
	76.5	55	2/13	7.8	1	L001M5	3336600177864	5	T
	76.5	55	2/13	7.8	1	L001M25	3336600185043	25	J

L002M

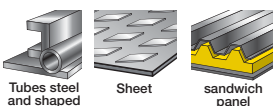

PANEL SANDWICHES AND COPPER



Features

- Milled and wavy set teeth. Flexible and long blade. Steel sheets, steelprofiles (1-3mm), sandwich materials (<80mm).

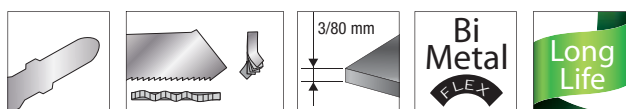

	L	Lu	mm/tpi	Larg.	Ep.	Ref.	Gencod	Qt.
	132	105	1/25	9.8	1	L002M5	3336600177871	5

PANEL SANDWICHES AND COPPER



Features

- Milled and wavy set teeth. Flexible and long blade. Steelprofiles, steelpipes (2,5-6mm), sandwich materials (<80mm), non-ferrous metal.



Carton card

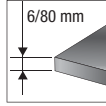
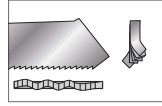
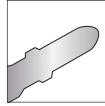

L	Lu	mm/tpi	Larg.	Ep.	Ref.	Gencod	Qt.
132	105	1.8/14	9.8	1	L003M5	3336600177888	5

Ref.

L003M

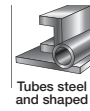

Tubes steel and shaped

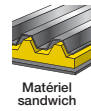

Matériel sandwich



No-ferrous metal



ALUMINIUM



Features

- Milled and side set teeth. Flexible blade. Aluminium, Non-Ferrous Metals (3-15mm), Steel, plastics (3-30mm).



Carton card



Quadrupack European hole

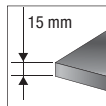
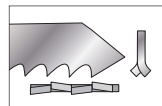
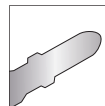

L	Lu	mm/tpi	Larg.	Ep.	Ref.	Gencod	Qt.	Pack
100	75	3/8.5	7.8	1	L004M5	3336600177895	5	T
100	75	3/8.5	7.8	1	L004M25	3336600185074	25	J

L004M



No-ferrous metal



ALU Aluminium



Stainless steel



STAINLESS STEEL



Features

- Carbide strip, grinded teeth. Steel, steelsheets, stainless steel (1,5-3,0mm).



Carton card

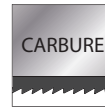
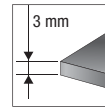
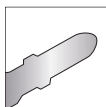

L	Lu	mm/tpi	Larg.	Ep.	Ref.	Gencod	Qt.
79	50	1.1	8.8	2.3	L005M2	3336600177901	2

L005M



Tubes steel and shaped

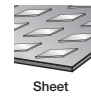

Sheet



Stainless steel



STEELSHEETS EXTRA THIN



Features

- Milled and wavy set. Flexible blade. Steel Sheets, profiles (1,2-2mm).



Carton card

Compatible Black & Decker

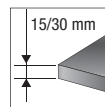
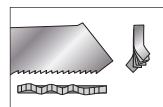

L	Lu	mm/tpi	Larg.	Ep.	Ref.	Gencod	Qt.
76.5	55	1.2/21	7.8	1	L102M5	3336600177949	5

L102M

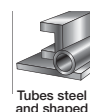

Tubes steel and shaped

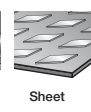

Sheet



WOOD RECIPROCATING SAW BLADE

Ref.

L200W

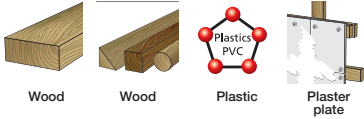

PLASTER AND CEMENT FIBRE



Features

- Milled and side set teeth. Fast cut. All wood types, plastics, pasterboard (6-100/250mm).

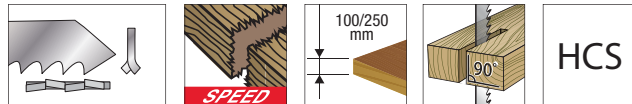

HCS

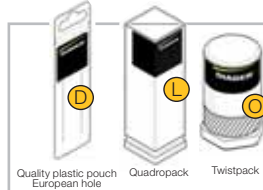

L	Lu	mm/tpi	Larg.	Ep.	Ref.	Gencod	Qt.	Pack
150	130	4.2/6	19	1.27	L200WL1505	3336600177963	5	D
150	130	4.2/6	19	1.27	L200WL15025	3336600184428	25	L
150	130	4.2/6	19	1.27	L200WL150100	3336600184640	100	O
300	280	4.2/6	19	1.27	L200WL3005	3336600177970	5	D

L201W



COMPOSITE MATERIALS



Features

- Milled and side set teeth. Flexible blade. Fast cut. All wood types, plastics, composite materials (6-100mm).

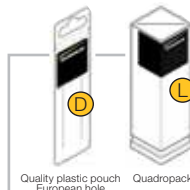
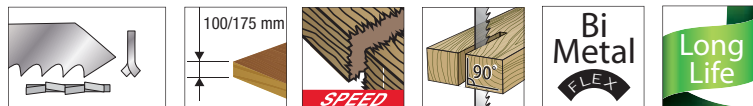

L	Lu	mm/tpi	Larg.	Ep.	Ref.	Gencod	Qt.	Pack
150	130	4.2/6	19	1.27	L201WL1505	3336600177987	5	D
150	130	4.2/6	19	1.27	L201WL150100	3336600184664	100	L
225	205	4.2/6	19	1.27	L201WL2255	3336600177994	5	D

L202W



GREEN WOOD



Features

- Sharpened, side set teeth and induction hardened teeth. Green wood, log (<190mm).

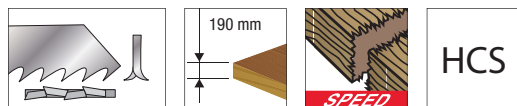

HCS

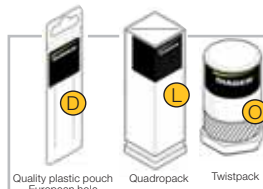

L	Lu	mm/tpi	Larg.	Ep.	Ref.	Gencod	Qt.	Pack
240	220	6.35/5 4/5	19	1.27	L202WL2405	3336600178007	5	D
240	220	6.35/5 4/5	19	1.27	L202WL24025	3336600184466	25	L
240	220	6.35/5 4/5	19	1.27	L202WL240100	3336600184688	100	O

INSULATION MATERIAL



Features

- Knife blade with double wave cut. Clean and fast cut. Insulation material, cardboard, leather, rubber (<250mm).



Quality plastic pouch
European hole

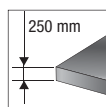

HCS

L	Lu	Larg.	Ep.	Ref.	Gencod	Qt.
300	280	19	1.27	L200SL3002	3336600178137	2

Ref.
L200S



Insulation



Leather



Rubber



Paperboard



Insulation



CAST, BRICK AND CERAMICS



Features

- Diamont gritted blade. Cast, brick, ceramics and composite materials.



Quality plastic pouch
European hole



DIAM



L	Lu	Larg.	Ep.	Ref.	Gencod	Qt.
200	180	19	1.05	L201SL2001	3336600178144	1

L201S



Cast iron



Brick



Hollow brick



Ceramic Tile



STAINLESS STEEL

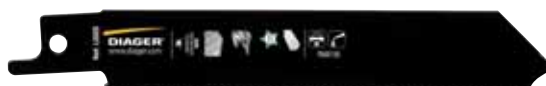

Features

- Tungsten carbide strip with grinded teeth. Stainless Steel, steelsheets, steelpipes, plexiglas, composite materials.



Quality plastic pouch
European hole

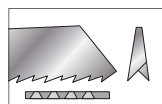

CARBURE

L	Lu	mm/tpi	Larg.	Ep.	Ref.	Gencod	Qt.
115	95	1.4/18	19	1.25	L202SL1152	3336600178151	2

L202S



Stainless steel



Sheet



Aciers tubes et profilés



Reinforced plastics



Plexiglass



SPECIFIC RECIPROCATING SAW BLADE

Ref.

L203S

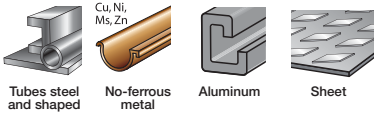

PROFILES AND PIPES



Features

- Milled and side set teeth. Twincut toothing. Flexible blade. Wood with nails/screws (<100/175mm), steelsheet, steelpipe, aluminium, non-ferrous metals (3-10mm).



L	Lu	mm/tpi	Larg.	Ep.	Ref.	Gencod	Qt.
150	130	2.5-1.8/10/14	19	0.9	L203SL1505	3336600178168	5
225	205	2.5-1.8/10/14	19	0.9	L203SL2255	3336600178175	5

L204S

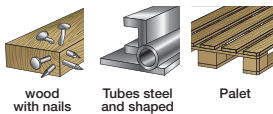

FOR WOOD WITH NAILS/SCREWS



Features

- Milled and side set teeth. Variable toothing. Flexible blade. Wood with nails/screws (<100/175/230mm), steelsheet, steelpipe, aluminium, non-ferrous metals (3-10mm).

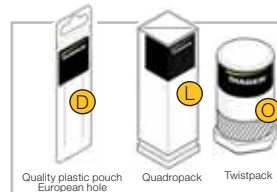

L	Lu	mm/tpi	Larg.	Ep.	Ref.	Gencod	Qt.	Pack
150	130	2.5-1.8/10/14	19	0.9	L204SL1505	3336600178014	5	D
150	130	2.5-1.8/10/14	19	0.9	L204SL15025	3336600184619	25	L
150	130	2.5-1.8/10/14	19	0.9	L204SL150100	3336600184831	100	O
225	205	2.5-1.8/10/14	19	0.9	L204SL2255	3336600178021	5	D
280	250	2.5-1.8/10/14	19	0.9	L204SL2805	3336600178038	5	D



Handle saw blades and screwdriver bits



One tool for screw driving and cutting application.

The multi-tool handle accepts 1/2" reciprocating saw blades and standard 1/4" hexagon bits.

Fast and simple tool change through rotatable locking ring.

Suitable to use in confined areas and where powered tools can no longer be used. Perfect solution in combination with suitable reciprocating saw blades for trimming isolation materials, soft materials, card board, polystyrene, soft foams, etc...

With appropriate saw blades the multi-tool can be used.

Qt.	Ref.	Gencod	UC
1	680	3336600187009	1

SPECIAL FOR FROZEN FOOD, ICE



Features

- Stainless steel, teeth milled and side set. Special blade for frozen food, ice up to 250 mm / 350 mm.



Quality plastic pouch
European hole

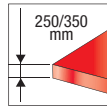
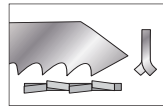

L	Lu	mm/tpi	Larg.	Ep.	Ref.	Gencod	Qt.
400	380	6.35/4	25	1.25	L205SL4001	3336600185920	1

Ref.
L205S



Features

- Cylindric tungsten carbide teeth. Special saw blade for straight cuts in lime sand brick, clinker and smearing materials for e.g. gas-formed concrete. Cutting width = 2.5 mm.



Quality plastic pouch
European hole

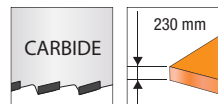

L	Lu	mm/tpi	Larg.	Ep.	Ref.	Gencod	Qt.
300	280	17/1,5	50	1.1	L206SL3001	3336600185944	1
400	380	17/1,5	20	1.1	L206SL4001	3336600187160	1

L206S



Brick



Hollow brick



SPECIAL DEMOLITION



Features

- Cylindric tungsten carbide teeth. Special saw blade for straight cuts in lime sand brick, clinker and smearing materials for e.g. gas-formed concrete. Cutting width = 2.5 mm.



Quality plastic pouch
European hole

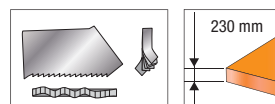

L	Lu	mm/tpi	Larg.	Ep.	Ref.	Gencod	Qt.
300	280	17/1.5	22	1.57	L206ML3005	3336600185937	5

L206M



Tubes steel
and shaped



Wood



Wood
with nails



Ref.

L200M

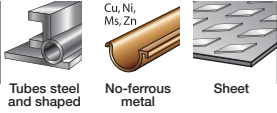

Tubes steel and shaped

No-ferrous metal

Sheet



STEELSHEETS AND PIPES



Features

- Milled and wavy set teeth. Flexible blade. Steelsheets, steelpipes, stainless steel (2,0-3,5mm), No-ferrous metal.

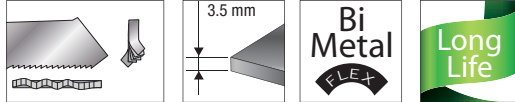

	L	Lu	mm/tpi	Larg.	Ep.	Ref.	Gencod	Qt.	Pack
	150	130	1.8/14	19	0.9	L200ML1505	3336600178045	5	D
	150	130	1.8/14	19	0.9	L200ML15025	3336600184473	25	L
	150	130	1.8/14	19	0.9	L200ML150100	3336600184695	100	O
	200	180	1.8/14	19	0.9	L200ML2005	3336600178052	5	D
	200	180	1.8/14	19	0.9	L200ML20025	3336600184480	25	L
	200	180	1.8/14	19	0.9	L200ML200100	3336600184701	100	O

L201M

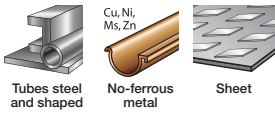

Tubes steel and shaped

No-ferrous metal

Sheet



FAST CUT



Features

- Milled and wavy set teeth. Flexible blade. Fast cut. Steelsheets, steelpipes, stainless steel (2-3,5mm), No-ferrous metal.

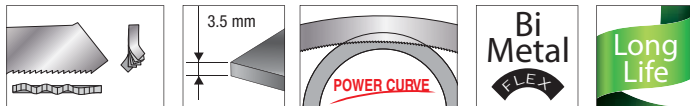

	L	Lu	mm/tpi	Larg.	Ep.	Ref.	Gencod	Qt.
	150	130	1.8/14	19	0.9	L201ML1505	3336600178069	5

L202M



Tubes steel and shaped



STEELSHEETS AND PIPES



Features

- Milled and wavy set teeth. Flexible blade. Steelsheets, steelpipes, stainless steel (1,5-2,5mm).

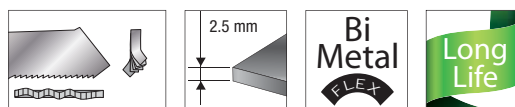

	L	Lu	mm/tpi	Larg.	Ep.	Ref.	Gencod	Qt.	Pack
	150	130	1.4/18	19	0.9	L202ML1505	3336600178076	5	D
	150	130	1.4/18	19	0.9	L202ML15025	3336600184503	25	L
	150	130	1.4/18	19	0.9	L202ML150100	3336600184725	100	O
	200	180	1.4/18	19	0.9	L202ML2005	3336600178083	5	D
	200	180	1.4/18	19	0.9	L202ML20025	3336600184510	25	L
	200	180	1.4/18	19	0.9	L202ML200100	3336600184732	100	O

FAST CUT



Features

- Milled and wavy set teeth. Flexible blade. Fast cut. Steelsheets, steelpipes, stainless steel (1,5-2,5mm). Non-ferrous metal.

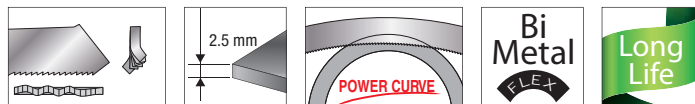

L	Lu	mm/tpi	Larg.	Ep.	Ref.	Gencod	Qt.
150	130	1.4/18	19	0.9	L203ML1505	3336600178090	5

Quality plastic pouch
European hole

Ref.

L203M



Tubes steel
and shaped



EXTRA THIN STEELSHEETS



Features

- Milled and wavy set teeth. Flexible blade. Finally toothed. Steelsheets, steelpipes, stainless steel (1,2-2mm). Non-ferrous metal.

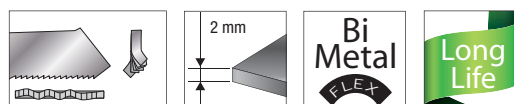

L	Lu	mm/tpi	Larg.	Ep.	Ref.	Gencod	Qt.
150	130	1/24	19	0.9	L204ML1505	3336600178106	5

Quality plastic pouch
European hole

L204M

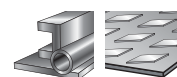

Tubes steel
and shaped

Sheet



THICK STEELSHEETS AND PIPE



Features

- Milled and wavy set teeth. Flexible blade. Steelsheets, steelpipes, stainless steel (3-5mm), Non-ferrous metal.

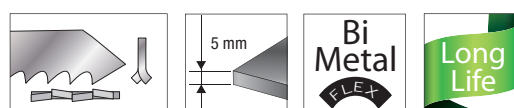

L205M



Tubes steel
and shaped

Cu, Ni,
Ms, Zn
No-ferrous
metal



L	Lu	mm/tpi	Larg.	Ep.	Ref.	Gencod	Qt.	Pack
150	130	2.5/10	19	0.9	L205ML1505	3336600178113	5	D
150	130	2.5/10	19	0.9	L205ML15025	3336600184541	25	L
150	130	2.5/10	19	0.9	L205ML150100	3336600184763	100	O
280	260	2.5/10	19	0.9	L205ML2805	3336600178120	5	D

Quality plastic pouch
European hole

Quadropack

Twistpack

CONCEPT FIXING

ON
DEMAND

"PAJIVOL" CONCEPT

Removable communication panel,
available for each type of plugs
Compose your range, according to your needs.
- Signage Before: Magnet
- Signage Side: Panel



SALES ANIMATIONS



For 24 cartridges of
your choice 300 / 400ml:
empty PLV: Ref.C00093
Display +24 cartridges beige:
Ref.F353000PG-CPT

For 96 cartridges of your choice 300 / 400ml:
empty PLV: Ref.C00072
Display +96 cartridges beige:
Ref.F353000PG-BOX



also for drilling concept



Designation	Ref.	Gencod
1M SALES SHELF	GOND1000	3336609000019
PEDIMENT FOR 1M SALES SHELF	FR1000	3336609000542
1M STAY FOR 1M SALES SHELF	BAR1000	3336609000057
STRUCTURE + 4 "PAJIVOLS"	M00110	33366090000460
CHUTE FOR PAJIVOL	M00111	33366090000606
SHELF FOR PAJIVOL	M00112	33366090000613
DOUBLE HOOK FOR PAJIVOL	M00113	33366090000620
SHELF 1M	TAB1000500	33366090000163

TEXTILE



SOFTSHELL JACKET



T-SHIRT ULTIMAX 646

Designation	Ref.
DIAGER CAP	GDBCASQUETTE
POLO MC DIAGER BLACK T.S	GDBPOLOS
POLO MC DIAGER BLACK T.M	GDBPOLOM
POLO MC DIAGER BLACK T.L	GDBPOLOL
POLO MC DIAGER BLACK T.XL	GDBPOLOXL
POLO MC DIAGER BLACK T.XXL	GDBPOLOXXL
POLO ML DIAGER BLACK T.S	GDBPOLOMLS
POLO ML DIAGER BLACK T.M	GDBPOLOMLM
POLO ML DIAGER BLACK T.L	GDBPOLOMLL
POLO ML DIAGER BLACK T.XL	GDBPOLOMLXL
POLO ML DIAGER BLACK T.XXL	GDBPOLOMLXXL
TSHIRT ULTIMAX646 SIZE M	GDBTS646M
TSHIRT ULTIMAX646 SIZE L	GDBTS646L
TSHIRT ULTIMAX646 SIZE XL	GDBTS646XL
SLEEVELESS SOFTSHELL T.S	GDBSOFTSHELLS
SLEEVELESS SOFTSHELL T.M	GDBSOFTSHELLM
SLEEVELESS SOFTSHELL T.L	GDBSOFTSHELLL
SLEEVELESS SOFTSHELL T.XL	GDBSOFTSHELLXL
SLEEVELESS SOFTSHELL T.XXL	GDBSOFTSHELLXXL
SOFTSHELL JACKET BLACK T.S	GDBVESTES
SOFTSHELL JACKET BLACK T.M	GDBVESTEM
SOFTSHELL JACKET BLACK T.L	GDBVESTEL
SOFTSHELL JACKET BLACK T.XL	GDBVESTEXL
SOFTSHELL JACKET BLACK T.XXL	GDBVESTEXXL



SLEEVELESS
SOFTSHELL



LONG SLEEVES
POLO



CAP



SHORT SLEEVES
POLO

CONCEPT STORE

GENERALIST ALL PRODUCTS

Planograms including drilling ranges
Concrete, Metal, Wood, Accessories,
Sawing and Screw drilling



1M GENERAL RANGE
ALL PRODUCTS



2M GENERAL RANGE
ALL PRODUCTS



1 M WOOD RANGE



1 M METAL RANGE



1 M SAWING AND SCREW BITS
RANGE

ADDITIONAL
RANGES



DRI LLING SPECIALI ST

Planograms including Concrete drilling
ranges, Accessories



1 M CONCRETE SPECIALIST



2 M CONCRETE SPECIALIST



0.5 M CONCRETE SPECIALIST

DRI LLING GENERALI ST

Planograms including
drilling ranges Concrete,
Metal, Wood, Accessories



1 M GENERAL



2 M GENERAL

ADVERTISING CONCEPT



P.O.S ADVERTISING CONCEPT

To animate your sales, mobile furniture that can be set up in TG or in the middle of the store. Implantation products in front and back on hooks and shelves.
Showcase with lock. Supplied accessories: 30 hooks and 2 shelves.
Structure delivered assembled.

Front side



side

Back side

Designation	Ref.	Gencod
P.O.S Advertising Concept	M00161	3336609005991

MODULAR CONCEPT



ROTATING STAND

Furniture suitable for the presentation of products in your linear or in the middle of the point of sale. Launch of a new range, highlighting products, or specific operation.

24-pin modular display rack

for all types of products. Ideal countertop or suspended on sales shelf. Delivered flat, to assemble. Rack delivered separately, structure can accommodate from 1 to 4 racks.



Floor display on wheels
Delivered assembled.
Supplied accessories:
10 pins + Briefcase

SALES ANIMATION

Designation	Ref.	Gencod	Visuel
1M SALES SHELF	GOND1000	3336609000019	-
1M SALES SHELF (TO BE CONNECTED WITH GOND1000)	GOND1001	3336609000033	-
0.5M SALES SHELF	GOND500	3336609000071	-
BOX WITH WHEELS FOR 1M SALES SHELF	M00124	3336609004253	1
BOX WITHOUT WHEELS FOR 1M SALES SHELF	M00128	3336609004260	2
BOX WITHOUT WHEELS FOR 1.33M SALES SHELF	M00127	3336609007322	2
LUMINAR PEDIMENT 1M	FRONTON	3336609004277	3
PEDIMENT FOR 1M SALES SHELF	FR1000	3336609005472	4
LUMINAR PEDIMENT 0.5M	FRONTON500	3336609005175	5
PEDIMENT FOR 0.5M SALES SHELF	FR500	3336609005373	6
ELECTRIC CABLE FOR LUMINAR PEDIMENT	CORDON	3336600187528	7
1M ASSEMBLY PACK	AM1000	3336609000026	-
ADJUSTABLE RACK WITH 20 DOUBLE HOOKS 1M	RAT1000DOUBLE	3336609002211	8
ADJUSTABLE RACK WITH 21 SIMPLE HOOKS 1M	RAT1000SIMPLE	3336609002228	9
ADJUSTABLE RACK WITH 10 SIMPLE HOOKS 0.5M	RAT500	3336609000088	10
ADJUSTABLE RACK WITHOUT HOOKS 1M	M00150	3336609004468	11
ADJUSTABLE RACK WITHOUT HOOKS 1.33M	M00159	3336609005984	11
ADJUSTABLE RACK WITHOUT HOOKS 0.5M	M00158	3336609005793	11
1M STAY FOR 1M SALES SHELF	BAR1000	3336609000057	12
0.5M STAY FOR 0.5M SALES SHELF	BAR500	3336609000095	13
DOUBLE HOOK	M00151	3336609004475	14
SIMPLE HOOK	M00152	3336609004482	15
LABEL SUPPORT FOR STAY (0.5M/1M)	SPE500	3336609000101	16
SHELF FOR SETS 0.5M	SCOFF	3336609000064	17
SHELF FOR SETS 0.90M	M00167	3336609006141	18
SHELF FOR SETS 1.25M	M00168	3336609006158	18
SHELF 1.M	TAB1000500	3336609000163	19
SHELF 1.M	TAB500500	3336609000187	19
DISPLAY CASE 1M FOR SETS	M00157	3336609005274	20
BIG DISPLAY CASE 1M FOR SETS	M00116	3336609002761	21
STORAGE UNIT WITH 2 DRAWERS	M00170	3336609006806	22
ANTI-THEFT 1M	ANTIVOL1000	3336609002037	23
ANTI-THEFT 0.5M	ANTIVOL500	3336609004291	23
ANTI-THEFT FOR HOOK	M00169	3336609006745	24
BACK COVER YELLOW 1M	M00010	3336600083776	25
HOOK FOR DIAMOND DISK	M00118	3336609004307	26
ANTI-THEFT FOR DIAMOND DISK	M00119	3336609004314	27
SUPPORT FOR DIAMOND CORE BIT	M00121	3336609004321	28
HOOK FOR CORE BIT 1/2	M00122	3336609004338	29
HOOK FOR CORE BIT 1-1/4	M00123	3336609004345	30
HOOK FOR CONSUMER INFORMATION	STOPRAYON	3336609000149	31
PR 24 DISPLAY - STRUCTURE ONLY	M00135	3336609005687	32
6 HOOKS RACK	M00101	3336609005694	33
BAR FOR REMOVABLE HOOK	M00102	3336609005717	34
REMOVABLE HOOK DOUBLE	M00103	3336609007339	35
COMMUNICATION KIT DIAGER	M00107	3336609005700	-
REVOLVING DISPLAY	M00129	3336609004352	36
STAND FOR REVOLVING DISPLAY	M00130	3336609004369	37
BRACKET	M00137	3336609004376	38
PIN FOR PERFORATED METAL SHEET	M00113	3336609000620	39
DYSPLAY HSS COUNTER	M00087	3336609000194	40

* Declined in several formats

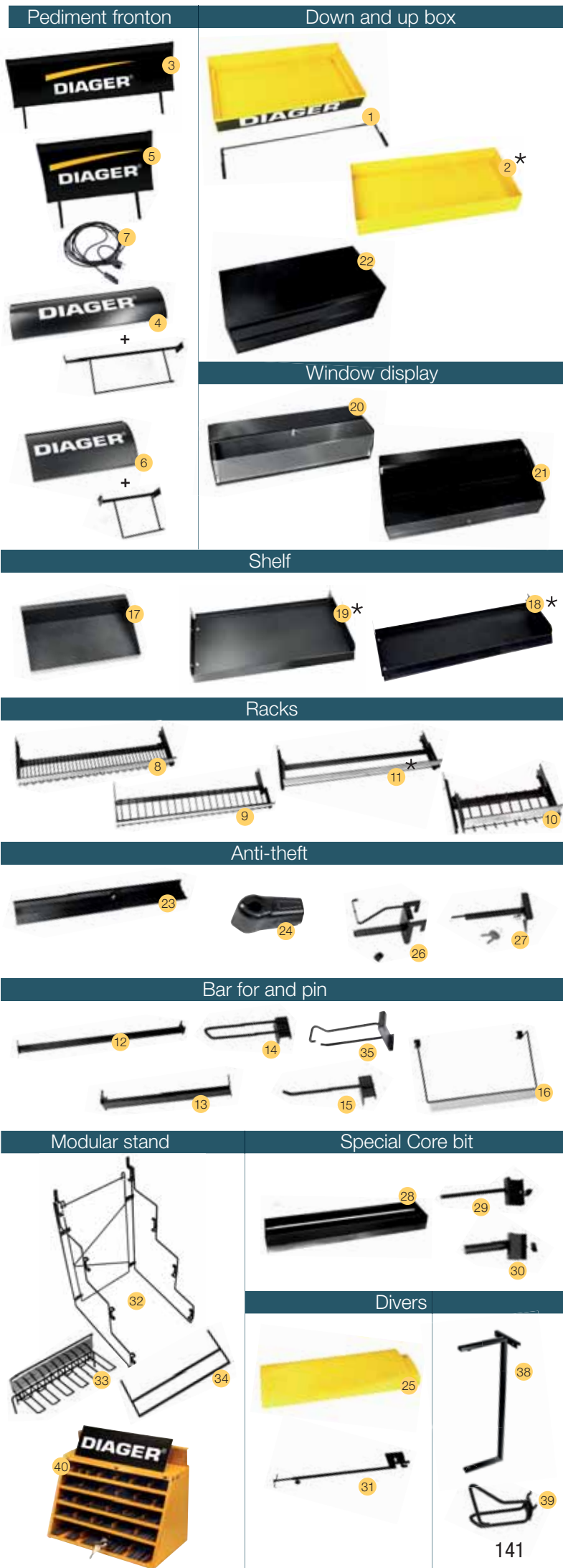

SERVICES PACK



ON LINE

Advice, Orders, Follow ups, etc. A dedicated service from 8 am to 12.30 pm (noon) and 1.30 pm to 5.30 pm.



PRODUCT EXPERTISE

DIAGER provides you with all of its human and technical resources.

DIAGER Experts:

- Analyse product problems.
- Provide new solutions.
- Intervene on the sites.

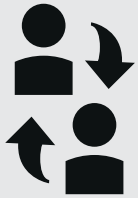

TRAINING

Technical skill is necessary for our shared success, so that's why DIAGER's teams are available to help you on a daily basis, advise you and provide theory and practical training sessions.

DIAGER reserves the sale of its products to professional distributors according to its general terms and conditions of sale that comply with article L 441-7 of the Code of Mercantile law. The data contained in this catalogue are those known upon its date of publication and are subject to change. Photographs are non-binding.

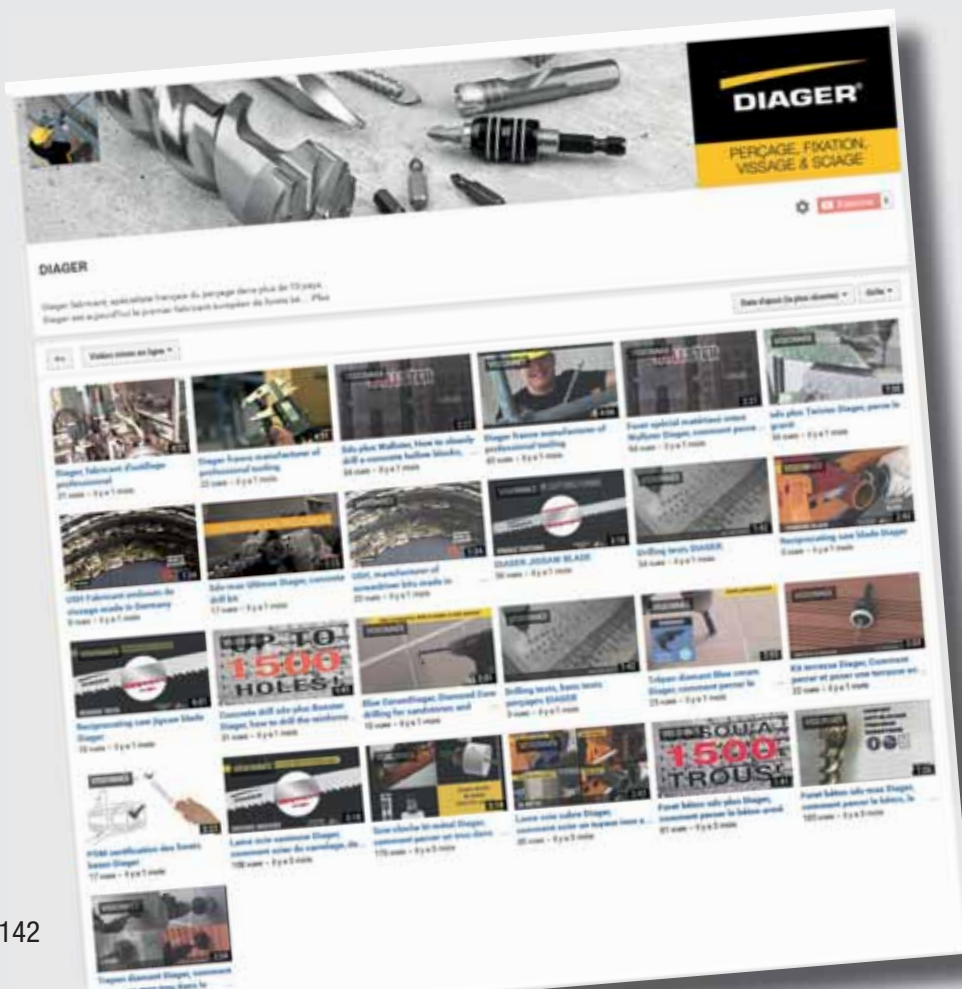

see our
video on
YouTube

Watch the videos is an excellent way to discover the features and strengths of our products.

www.diager.com

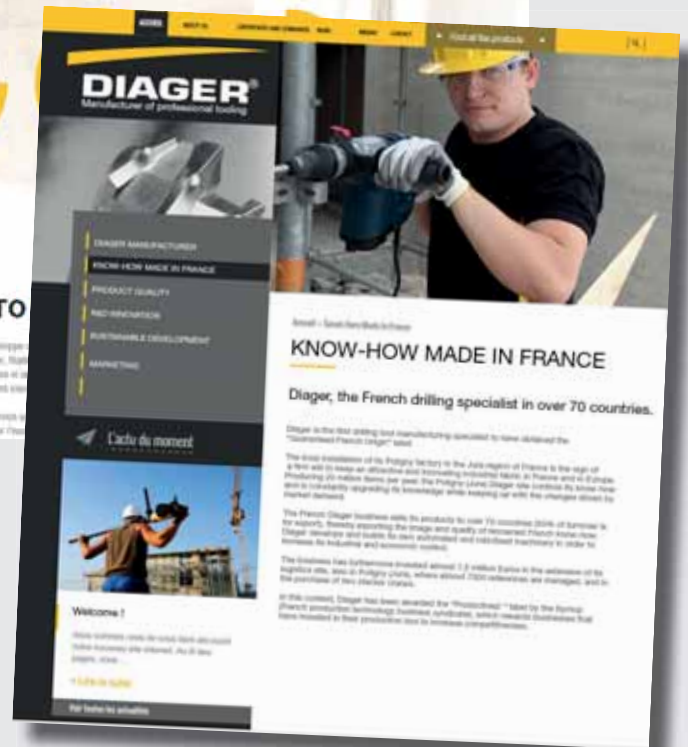
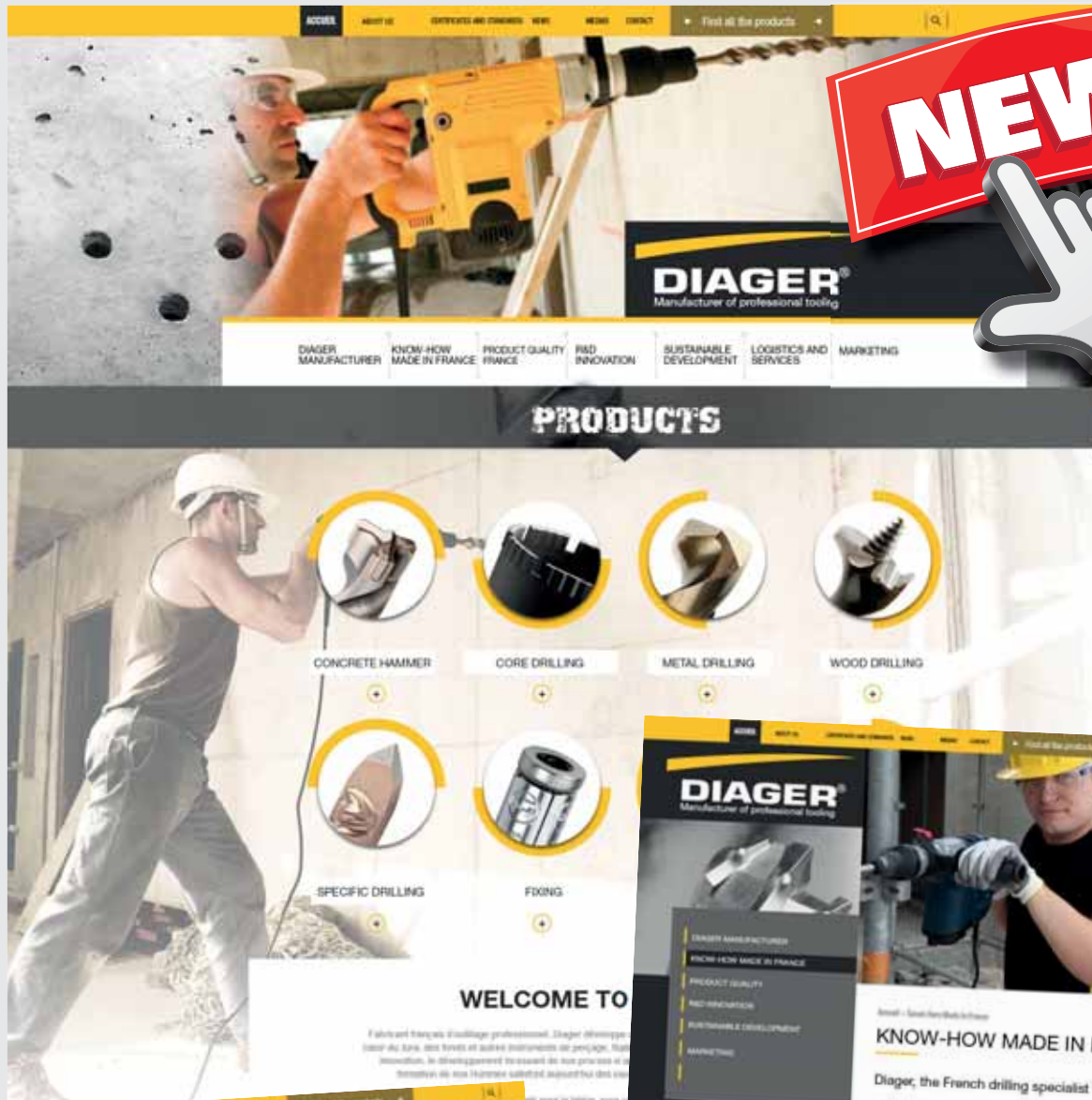

VISIT OUR WEB SITE

Use our browser to find your product.
Download the documentation you need.

**DRILLING
SCREW BITS
SAWING**

DIAGER®

PROFESSIONAL TOOLS MANUFACTURER

www.diager.com



Rue Henri Moissan
BP 90149
39802 POLIGNY Cedex 2
FRANCE

Tel. +33 (0)3 84 73 74 75
Fax +33 (0)3 84 73 74 76

contact@diager.com